

PORTA-PAK *Specials*



O-RINGS

1/16 P/N 19501

3/32 P/N 19502

1/8 P/N 19506

- O-Rings withstand temperatures of -40 to +300°F
- Resists gasoline, motor oil, transmission oil, water, mild acids, mild alkalis, anti-freeze
- Use in drain plug gaskets, fuel lines, engine seals, carburetors, garden power equipment

1/16 O-RINGS P/N 19501

QTY	O-RING SIZE	PART #
50	1/8 x 1/4 - 1/16 O-RING	60001
50	1/4 x 3/8 - 1/16 O-RING	60005
40	3/8 x 1/2 - 1/16 O-RING	60007
30	1/2 x 5/8 - 1/16 O-RING	60009

3/32 O-RINGS P/N 19502

QTY	O-RING SIZE	PART #
50	1/8 x 5/16 - 3/32 O-RING	63104
50	1/4 x 7/16 - 3/32 O-RING	63108
40	3/8 x 9/16 - 3/32 O-RING	60026
30	1/2 x 11/16 - 3/32 O-RING	60028

1/8 O-RINGS P/N 19506

QTY	O-RING SIZE	PART #
40	3/16 x 7/16 - 1/8 O-RING	63201
40	1/4 x 1/2 - 1/8 O-RING	63202
30	3/8 x 5/8 - 1/8 O-RING	63204
25	1/2 x 3/4 - 1/8 O-RING	63206

PORTA-PAK *Specials*



METRIC BUNA-N O-RINGS

P/N 19507

- Tough, 70 durometer Buna "N" (Nitrile Rubber) stock – provides superior resistance to gasoline, motor oil, transmission oil, hydraulic fluids, anti-freeze, mild acids, mild alkalies and water

- Precision manufactured to exacting specifications – assuring maximum leakage protection
- Temperature range: -65°F to 300°F (-54°C to 149°C)
- Ideal for use in engines, equipment, fuel systems, carburetors, drain lines, etc.

QUANTITY	O-RING SIZE	PART #
50	2mm x 6 x 10 O-RING	60923
50	2mm x 8 x 12 O-RING	60925
40	2mm x 10 x 14 O-RING	60927
30	2mm x 12 x 16 O-RING	60929

SHOP SUPPLIES

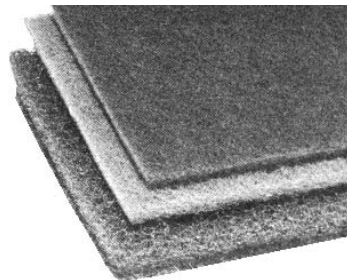
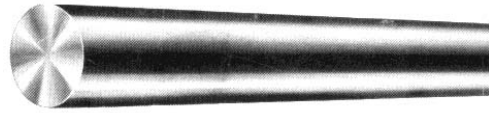

- Hose Clamps, 2-Ear Clamps, Constant Pressure Clamps
- Key Stock, O-Rings, Files, Abrasives, Cut-off Wheels, Wire Brushes
- Utility Knives, Shop Tools, Air Guns, Pliers and Specialty Tools
- Quality Industrial Tapes
- Springs, Hooks, Screw Eyes, Screw Extractors, Thread Locking Products
- Wipes, Absorbents and Spill Containment
- Work Lighting, Emergency Lighting, LED Flashlights
- Bioremediation Parts Washer - SmartWasher® Systems

FROM ABRASIVES TO WIRE BRUSHES, CHROMATE FULFILLS ALL YOUR SHOP SUPPLY REQUIREMENTS. **Quality products designed for professional use, in professional shops.**



CHROMATE INDUSTRIAL CORP.

QUALITY BUILDS CONFIDENCE, SERVICE EARNS TRUST.

BAR AND KEY STOCK

JUST CUT, FILE AND FIT

Make your own machinery keys by simply cutting, filing and fitting key and bar stock. Bars are greaseless, rust-resistant and easily identified from size marked on each bar.

ROUND BAR STOCK



3 FOOT LENGTHS

- 50% STRONGER THAN HOT-ROLLED STEEL
- COLD DRAWN, POLISHED, UNPLATED FINISH
- MACHINE CUT ENDS
- OPEN-HEARTH STEEL
- TENSILE STRENGTH - 85,000 P.S.I.
- BRINELL HARDNESS - 165 TO 180
- TOLERANCES: +.000" TO -.002"

SIZE	PART	SIZE	PART
1/8	F 5471	1/2	C 5483
3/16	F 5473	9/16	C 5485
1/4	F 5475	5/8	C 5487
5/16	C 5477	3/4	A 5489
3/8	C 5479	7/8	A 5491
7/16	C 5481	1	A 5493

WOODRUFF KEYS



WIDTH X DIA.	PART	WIDTH X DIA.	PART
3/32 x 1/2	R 60144	3/16 x 1-1/8	N 60156
3/32 x 5/8	R 60145	3/16 x 1-1/4	N 60157
1/8 x 1/2	R 60146	1/4 x 3/4	R 60158
1/8 x 5/8	R 60147	1/4 x 7/8	R 60159
1/8 x 3/4	R 60148	1/4 x 1	R 60160
5/32 x 5/8	R 60149	1/4 x 1-1/8	N 60161
5/32 x 3/4	R 60150	1/4 x 1-1/4	N 60162
5/32 x 7/8	R 60151	5/16 x 1	N 60163
3/16 x 5/8	R 60152	5/16 x 1-1/8	N 60164
3/16 x 3/4	R 60153	5/16 x 1-1/4	N 60165
3/16 x 7/8	R 60154	3/8 x 1	N 60166
3/16 x 1	R 60155	3/8 x 1-1/4	L 60167

SQUARE KEY STOCK

PLATED

- MACHINE CUT ENDS
- TOLERANCES: -.000 TO +.002 IN BOTH DIMENSIONS
- P.S.I. - 85,000
- B.H.N. - 165 TO 180



UNDERSIZED & UNPLATED

- MACHINE CUT ENDS
- TOLERANCES: -.002 TO +.000 IN BOTH DIMENSIONS
- P.S.I. - 85,000
- B.H.N. - 165 TO 180



12" LENGTHS

PLATED	PART	UNPLATED	PART
1/16	E 60180	1/16	E 50180
3/32	E 60181	3/32	E 50181
1/8	E 60182	1/8	E 50182
3/16	E 60183	3/16	E 50183
1/4	E 60184	1/4	E 50184
5/16	E 60185	5/16	E 50185
3/8	E 60186	3/8	E 50186
7/16	C 60187	7/16	C 50187
1/2	C 60188	1/2	C 50188
5/8	B 60189	5/8	B 50189
3/4	A 60190	3/4	A 50190
1"	A 60191	1"	A 50191

SQUARE KEY STOCK ASSORTMENT

- 7 MOST POPULAR SIZES
- A "MUST" FOR EVERY SHOP
- HUNDREDS OF APPLICATIONS
- A MULTI-PURPOSE ITEM USED IN ALL PHASES OF MAINTENANCE
- THE RIGHT SIZE AVAILABLE EVERY TIME



DESCRIPTION	PART
31 PIECE ASSORTMENT • 5 each — 1/8, 3/16, 1/4, 5/16 and 3/8 • 3 each — 7/16 • 3 each — 1/2	A 7793

CONSTANT PRESSURE CLAMPS

Did you know hoses can leak when there is a wide variation in underhood temperatures?

Thermal expansion and contraction loosens hose clamps over time. When leaks happen, it is usually something critical. The WaveSeal 360™ hybrid smart clamp solves this problem. Now you can purchase a hose clamp that's smart enough to adjust to the changing underhood environment. It's a whole new way to think about connections because the WaveSeal 360™:

- Utilizes a patented wave ring technology that self adjusts automatically as thermal cycling occurs
- Expands or contracts as the sealed joint changes, maintaining a constant, steady pressure 360 degrees around the connection
- Produces a sealing o-ring effect that prevents leakage
- Is much lighter, smarter and more compact than T-bolt and Belleville clamps
- All stainless steel construction

Discover the Holding Power of the WaveSeal 360™

Thermal cycling, cold flow & temperature fluctuations are among the main reasons leaks occur. The uniquely engineered W-shaped profile of the WaveSeal 360™ hybrid smart clamp secures hose connections and prevents the unwanted flow of fluids and air. Through its patented smart hybrid technology, the clamp seals in a steady 360-degree pattern in response to pressure and temperature changes. With its compact design and lower profile, you get the optimal heavy-duty constant tension clamp without all the bulk.



U.S. Patent No. 7,178,204 B2

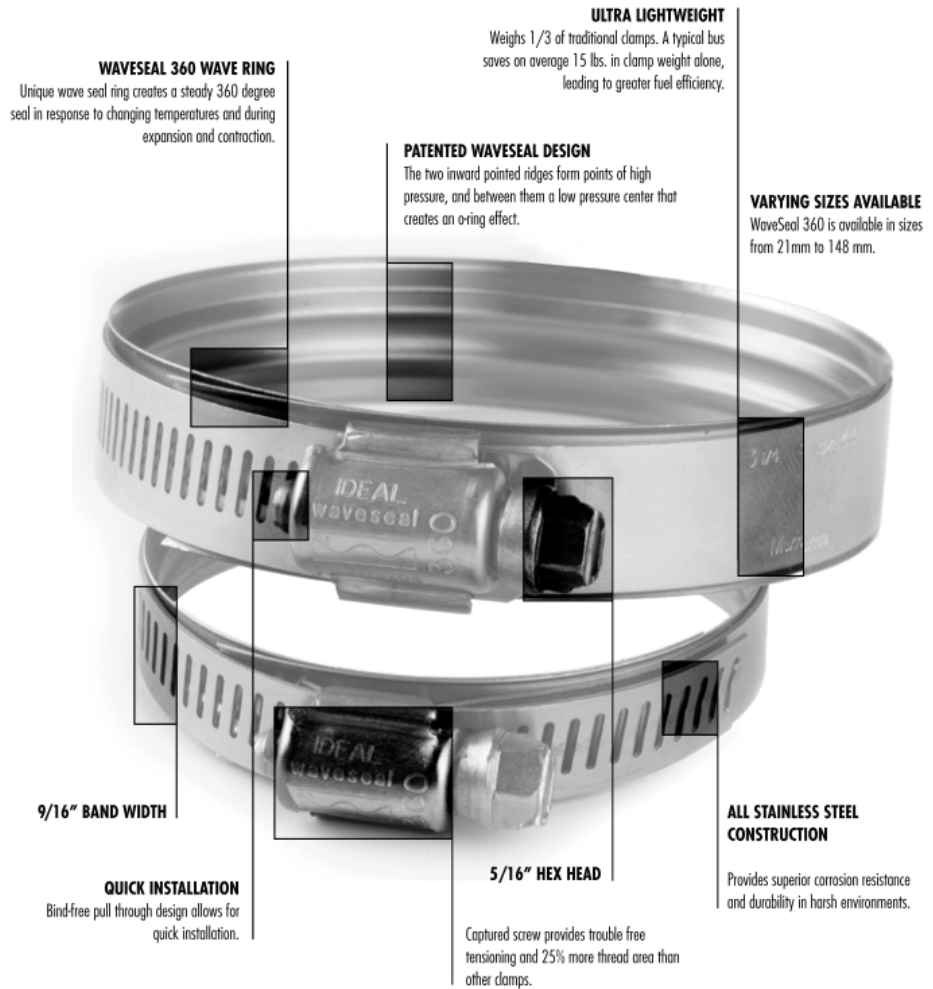

P/N	SIZE	MIN-MAX Diameter (mm)	MIN-MAX Diameter (inch)
30280	I	0016	21 to 33
30281	I	0019	27 to 35
30282	I	0020	26 to 40
30283	I	0022	29 to 43
30284	I	0024	30 to 46
30285	E	0028	34 to 52
30286	E	0032	39 to 59
30287	E	0034	41 to 62
30288	E	0036	43 to 65
30289	E	0040	46 to 71
30290	E	0044	52 to 78
30291	E	0048	56 to 84
30292	E	0052	60 to 91
30293	E	0056	64 to 97
30294	E	0060	68 to 103
30295	E	0064	71 to 110
30296	E	0072	81 to 122
30297	E	0080	90 to 135
30298	C	0088	97 to 148

CONSTANT PRESSURE CLAMPS

How the WaveSeal 360™ Beats T-Bolt & Belleville Clamps

The WaveSeal 360™ Clamp was designed in response to the leakage attributed to thermal cycling, plus today's challenging lighter weight and space constraints.



Integrated Two-piece Design

The WaveSeal 360™ is comprised of two main parts, the clamp assembly and the wave ring

- The wave ring is high quality stainless steel and inside the clamp
- Specifically tempered, thin gauge steel reacts to temperatures
- Becomes a smart clamp on the hose, expanding or contracting with temperatures
- The clamp rides on this ring so pressure is more evenly distributed around the hose

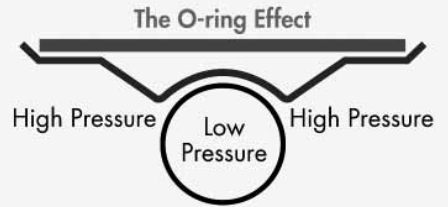

Seals Tight, Seals Right

The wave ring cross section resembles a W. When torqued under the clamp, the two points of high pressure surround the low point in between. This creates a powerful low pressure area much like an o-ring, which holds the hose securely and uniformly, maintaining a steady 360° seal.

Ultra Lightweight and Compact

The WaveSeal 360's™ lightweight design can literally shave pounds of vehicle weight while its low profile fits in tight spaces.

Tested Tough

Recent leak pressure tests show that the WaveSeal 360™ clamp performed better in thermal cycling than typical constant tension clamps, Belleville spring or spring loaded T-bolt styles. Further testing revealed WaveSeal 360™ performs even better over time when compared to other leading brands in the same category.

WaveSeal 360™ Clamps are engineered to last longer, and perform better than old-school clamps in the most demanding applications.

Passenger Car Cooling and Forced Induction Systems

Higher underhood temperatures associated with lower emissions lead to stress on cooling systems and turbos under pressure. Spring and worm gear clamps can leak under pressure.

Heavy Duty Cooling and Forced Induction Systems

This extended life, high vibration and thermal cycling prone environment makes turbo, radiator, heater and other cooling system hoses loosen more often with old-school clamps.

Off Highway Applications

Constant vibration and destructive shock peaking cause stress on traditional clamps.

Industrial and Hardware Applications

Corrosive environments, extreme temperatures and high vibration combine to cause traditional clamps to fail.

Extreme Climate Applications

Harsh environmental conditions require additional security for a hose connection, and old-style clamps fail regularly. Vehicles used in arctic or desert environments are more than transport, they're a lifeline.

Racing Applications

Experimental and high performance engines maximize performance... along with high heat and vibration under the cowl. The clamps should be just as high-tech.



HOSE CLAMPS

WORM DRIVE TYPE

Secures all types of push on hose in fuel line, air line, radiator, vacuum and heater applications. Stainless steel and tough precision engineered construction prevents rust and corrosion.

MINI-CLAMPS — UNLINED (5/16" BAND)

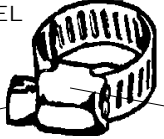
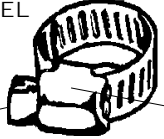
ALL STAINLESS STEEL		 <ul style="list-style-type: none"> • STAINLESS STEEL BAND, HOUSING AND SCREW 	PART STAINLESS STEEL		 <ul style="list-style-type: none"> • STAINLESS STEEL BAND 	
1/4" S/S HEX-HEAD SLOTTED SCREW	ONE-PIECE HOUSING		1/4" HEX-HEAD SLOTTED SCREW	ONE-PIECE HOUSING		
CLAMP RANGE	INDUSTRY #	ALL STAINLESS STEEL	PARTIAL STAINLESS STEEL	CLAMP RANGE	INDUSTRY #	ALL STAINLESS STEEL
1/4 to 5/8	4	40507	40404	1/2 to 1	8	40511
5/16 to 7/8	6	40508	40406	5/8 to 1-1/4	12	40513

HEAVY-DUTY HOSE CLAMPS — LINED AND UNLINED (9/16" BAND)

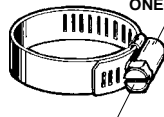
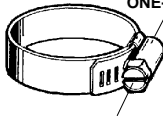
ALL STAINLESS STEEL		PART STAINLESS STEEL		LINED CLAMP ALL STAINLESS STEEL		<ul style="list-style-type: none"> • LINER PROTECTS SOFT RUBBER HOSE FROM EXTRUSION AND SHEARING THROUGH THE CLAMP BAND NOTCHES, YET STILL PROVIDES FULL SEALING EFFICIENCY. • NO SPOT WELDS TO RUPTURE — IDEAL FOR USE WITH SILICONE HOSE AND OTHER HOSES MADE OF SOFT MATERIALS. • ALL STAINLESS STEEL CONSTRUCTION FOR HIGH CORROSION RESISTANCE. 			
 <ul style="list-style-type: none"> • STAINLESS STEEL BAND, HOUSING AND SCREW 	ONE-PIECE HOUSING	 <ul style="list-style-type: none"> • STAINLESS STEEL BAND 	ONE-PIECE HOUSING	 <ul style="list-style-type: none"> • STAINLESS STEEL BAND, HOUSING AND SCREW 	ONE-PIECE HOUSING				
	3/8" S/S HEX-HEAD SLOTTED SCREW				3/8" HEX-HEAD SLOTTED SCREW		3/8" S/S HEX-HEAD SLOTTED SCREW		
CLAMP RANGE	INDUSTRY #	UNLINED ALL S/S	UNLINED PARTIAL S/S	LINED ALL S/S	CLAMP RANGE	INDUSTRY #	UNLINED ALL S/S	UNLINED PARTIAL S/S	LINED ALL S/S
3/8 to 7/8	6	30006	30306	-	1-5/16 to 3-1/4	44	30044	30344	30244
7/16 to 1	8	30008	30308	30208	1-5/8 to 3-1/2	48	30048	30348	30248
1/2 to 1-1/8	10	30010	30310	30210	1-7/8 to 3-3/4	52	30052	30352	30252
1/2 to 1-1/4	12	30012	30312	30212	2-1/8 to 4	56	30056	30356	30256
3/4 to 1-1/2	16	30016	30316	30216	2-5/8 to 4-1/2	64	30064	30364	30264
3/4 to 1-3/4	20	30020	30320	30220	3-1/8 to 5	72	30072	30372	30272
1 to 2	24	30024	30324	30224	3-5/8 to 5-1/2	80	30080	30380	-
1-5/16 to 2-1/4	28	30028	30328	30228	4-1/4 to 6	88	30088	30388	-
1-9/16 to 2-1/2	32	30032	30332	30232	4-3/4 to 6-1/2	96	30096	30496	-
7/8 to 2-3/4	36	30036	30336	30236	4 to 7	104	30104	30314	-
1-1/8 to 3	40	30040	30340	30240	5-7/8 to 7-3/4	114	30116	-	-

27

HOSE CLAMP ASSORTMENTS

Sturdy steel wire rack keeps all your hose clamps in one convenient location. Ten of each of the most popular sizes. Easy to pull, easy to return, with no more missing boxes.

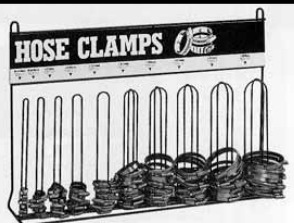
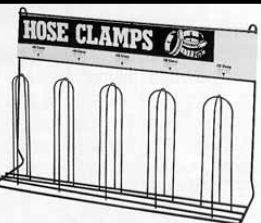
 	DESCRIPTION	PART
	Assortment #1 (Industry #4 through #36) Contains 10 each of 40507, 40508, 30006, 30010, 30012, 30016, 30020, 30028, 30032 and 30036	A 7794
Assortment #2 (Industry #40 through #72) Contains 10 each of 30040, 30048, 30052, 30056 and 30072	A 7796	

2-EAR CLAMPS

MATERIALS CAN BE SECURELY FASTENED

2-Ear Clamps are suitable for use by OEMs, but also for maintenance, repair and service purposes. With this type of clamp, rubber hoses, plastic tubing, electrical cables, welding hoses, and other materials can be securely fastened.

Compared to 1-ear clamps, 2-ear clamps are suitable for a wider diameter range. The geometry of the closed ears increases the effective clamping force, and provides a degree of elasticity to accommodate changes in size of the parts being joined, such as may be caused by thermal expansion or vibration. For perfect sealing, it is essential that the ears are correctly closed during installation.

ZINC PLATED

- STURDY DESIGN FOR GOOD, PERMANENT SEALING
- IDEAL FOR AIR AND LIQUID LINES
- FAST, SIMPLE, SECURE INSTALLATION
- 2-EAR DESIGN GIVES INCREASED CLAMPING RANGE
- DE-BURRED EDGES PREVENTS DAMAGE TO CLAMPED PARTS
- DEFORMATION OF EARS PROVIDES VISUAL INDICATION THE CLAMP IS CLOSED



SIZE RANGE (INCH)	SIZE RANGE (MILLIMETERS)		PART
9/32" - 23/64"	7 - 9	N	30117
5/16" - 7/16"	8.1 - 11	N	30118
27/64" - 33/64"	10.8 - 13	N	30119
31/64" - 19/32"	12.5 - 15	L	30120
5/8" - 3/4"	16 - 19	L	30121
41/64" - 51/64"	16.2 - 20	L	30122
3/4" - 29/32"	19 - 23	L	30123
53/64" - 31/32"	21 - 25	I	30124
57/64" - 1-1/16"	22.5 - 27	I	30125
15/16" - 1-7/64"	24 - 28	I	30126
1-3/64" - 1-7/32"	26.3 - 31	I	30127
1-5/32" - 1-11/32"	29.3 - 34	I	30128

27

MANUALLY OPERATED HAND TOOLS FOR 2-EAR CLAMPS

The appropriate manually operated hand tool (**P/N 66385 or 66386**) is applied to the ears and closed with sufficient force to draw the lower radii together to a position where obvious component compression is evident and the clamp ear assumes a symmetrical "omega" shaped formation.



Side Jaw Pincers, P/N 66385
(One item per pkg.)



Standard Jaw Pincers, P/N 66386
(One item per pkg.)

O-RINGS - BUNA-N

BUNA "N" COMPOUND

General purpose O-Rings withstand temperatures of -40°F to +300°F.

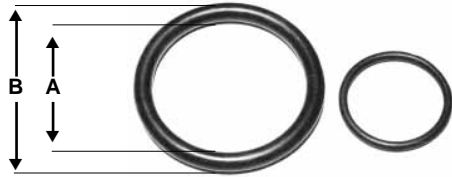

RESISTS:

- GASOLINE
- MOTOR OIL
- TRANSMISSION OIL
- WATER
- MILD ACIDS
- MILD ALKALIS
- ANTI-FREEZE

USE IN:

- DRAIN PLUG GASKETS
- FUEL LINES
- ENGINE SEALS
- CARBURETORS
- GARDEN POWER EQUIPMENT



1/16" THICK



I.D. (A)	O.D. (B)	INDUSTRY#	PART	I.D. (A)	O.D. (B)	INDUSTRY#	PART	I.D. (A)	O.D. (B)	INDUSTRY#	PART
1/32	3/32	001	N 63001	9/16	11/16	015	N 60010	1-1/2	1-5/8	029	N 60020
3/64	9/64	002	N 60000	5/8	3/4	016	N 60011	1-5/8	1-3/4	030	N 60090
1/16	3/16	003	N 60083	11/16	13/16	017	N 60012	1-3/4	1-7/8	031	N 60091
5/64	13/16	004	N 60084	3/4	7/8	018	N 60013	1-7/8	2	032	N 60092
3/32	7/32	005	N 60085	13/16	15/16	019	N 60014	2	2-1/8	033	N 60093
1/8	1/4	006	N 60001	7/8	1	020	N 60015	2-1/8	2-1/4	034	N 60094
5/32	9/32	007	N 60002	15/16	1-1/16	021	N 60016	2-1/4	2-3/8	035	N 60095
3/16	5/16	008	N 60003	1	1-1/8	022	N 60017	2-3/8	2-1/2	036	N 60096
7/32	11/32	009	N 60004	1-1/16	1-3/16	023	N 60018	2-1/2	2-5/8	037	N 60097
1/4	3/8	010	N 60005	1-1/8	1-1/4	024	N 60019	2-5/8	2-3/4	038	N 60098
5/16	7/16	011	N 60006	1-3/16	1-5/16	025	N 60086	2-3/4	2-7/8	039	N 63039
3/8	1/2	012	N 60007	1-1/4	1-3/8	026	N 60087	2-7/8	3	040	N 63040
7/16	9/16	013	N 60008	1-5/16	1-7/16	027	N 60088	3	3-1/8	041	N 63041
1/2	5/8	014	N 60009	1-3/8	1-1/2	028	N 60089	-	-	-	-

3/32" THICK

I.D. (A)	O.D. (B)	INDUSTRY#	PART	I.D. (A)	O.D. (B)	INDUSTRY#	PART	I.D. (A)	O.D. (B)	INDUSTRY#	PART
1/16	1/4	102	N 63102	15/16	1-1/8	119	N 60035	2	2-3/16	136	N 63136
3/32	9/32	103	N 63103	1	1-3/16	120	N 60036	2-1/16	2-1/4	137	N 63137
1/8	5/16	104	N 63104	1-1/16	1-1/4	121	N 60037	2-1/8	2-5/16	138	N 63138
5/32	11/32	105	N 63105	1-1/8	1-5/16	122	N 60038	2-3/16	2-3/8	139	N 63139
3/16	3/8	106	N 63106	1-3/16	1-3/8	123	N 60039	2-1/4	2-7/16	140	N 63140
7/32	13/32	107	N 63107	1-1/4	1-7/16	124	N 60040	2-5/16	2-1/2	141	N 63141
1/4	7/16	108	N 63108	1-5/16	1-1/2	125	N 63125	2-3/8	2-9/16	142	N 63142
5/16	1/2	109	N 63109	1-3/8	1-9/16	126	N 63126	2-7/16	2-5/8	143	N 63143
3/8	9/16	110	N 60026	1-7/16	1-5/8	127	N 63127	2-1/2	2-11/16	144	N 63144
7/16	5/8	111	N 60027	1-1/2	1-11/16	128	N 63128	2-9/16	2-3/4	145	N 63145
1/2	11/16	112	N 60028	1-9/16	1-3/4	129	N 63129	2-5/8	2-13/16	146	N 63146
9/16	3/4	113	N 60029	1-5/8	1-13/16	130	N 63130	2-11/16	2-7/8	147	N 63147
5/8	13/16	114	N 60030	1-11/16	1-7/8	131	N 63131	2-3/4	2-15/16	148	N 63148
11/16	7/8	115	N 60031	1-3/4	1-15/16	132	N 63132	2-13/16	3	149	N 63149
3/4	15/16	116	N 60032	1-13/16	2	133	N 60041	2-7/8	3-1/16	150	N 63150
13/16	1	117	N 60033	1-7/8	2-1/16	134	N 63134	3	3-3/16	151	N 63151
7/8	1-1/16	118	N 60034	1-15/16	2-1/8	135	N 63135	-	-	-	-

O-RINGS – BUNA-N (Cont'd.)

1/8" THICK											
I.D. (A)	O.D. (B)	INDUSTRY#	PART	I.D. (A)	O.D. (B)	INDUSTRY#	PART	I.D. (A)	O.D. (B)	INDUSTRY#	PART
3/16	7/16	201	N 63201	15/16	1-3/16	213	N 60052	1-3/4	2	224	N 60063
1/4	1/2	202	N 63202	1	1-1/4	214	N 60053	1-7/8	2-1/8	225	N 63225
5/16	9/16	203	N 63203	1-1/16	1-5/16	215	N 60054	2	2-1/4	226	N 63226
3/8	5/8	204	N 63204	1-1/8	1-3/8	216	N 60055	2-1/8	2-3/8	227	N 63227
7/16	11/16	205	N 63205	1-3/16	1-7/16	217	N 60056	2-1/4	2-1/2	228	N 63228
1/2	3/4	206	N 63206	1-1/4	1-1/2	218	N 60057	2-3/8	2-5/8	229	N 63229
9/16	13/16	207	N 63207	1-5/16	1-9/16	219	N 60058	2-1/2	2-3/4	230	N 63230
5/8	7/8	208	N 60047	1-3/8	1-5/8	220	N 60059	2-5/8	2-7/8	231	N 63231
11/16	15/16	209	N 60048	1-7/16	1-11/16	221	N 60060	2-3/4	3	232	N 63232
3/4	1	210	N 60049	1-1/2	1-3/4	222	N 60061	2-7/8	3-1/8	233	N 63233
13/16	1-1/16	211	N 60050	1-5/8	1-7/8	223	N 60062	3	3-1/4	234	N 63234
7/8	1-1/8	212	N 60051	-	-	-	-	-	-	-	-
3/16" THICK											
I.D. (A)	O.D. (B)	INDUSTRY#	PART	I.D. (A)	O.D. (B)	INDUSTRY#	PART	I.D. (A)	O.D. (B)	INDUSTRY#	PART
7/16	13/16	309	N 63309	1-1/16	1-7/16	319	N 63319	2	2-3/8	329	N 60073
1/2	7/8	310	N 63310	1-1/8	1-1/2	320	N 63320	2-1/8	2-1/2	330	N 60074
9/16	15/16	311	N 63311	1-3/16	1-9/16	321	N 63321	2-1/4	2-5/8	331	N 60075
5/8	1	312	N 63312	1-1/4	1-5/8	322	N 63322	2-3/8	2-3/4	332	N 60076
11/16	1-1/16	313	N 63313	1-5/16	1-11/16	323	N 63323	2-1/2	2-7/8	333	N 60077
3/4	1-1/8	314	N 63314	1-3/8	1-3/4	324	N 63324	2-5/8	3	334	N 60078
13/16	1-3/16	315	N 63315	1-1/2	1-7/8	325	N 60069	2-3/4	3-1/8	335	N 60079
7/8	1-1/4	316	N 63316	1-5/8	2	326	N 60070	2-7/8	3-1/4	336	N 60080
15/16	1-5/16	317	N 63317	1-3/4	2-1/8	327	N 60071	3	3-3/8	337	N 60081
1	1-3/8	318	N 63318	1-7/8	2-1/4	328	N 60072	-	-	-	-

O-RING BULK STOCK 10 FT. LENGTHS				RL INSTANT ADHESIVE			
							
SIZE		PART		SIZE		PART	
3/32	A	840		1/4	A	843	
1/8	A	841		5/16	A	844	
3/16	A	842		3/8	A	845	
DESCRIPTION						PART	
Red Lion™ Instant Adhesive						c	74516

27

O-RING SPLICING KIT		
	<ul style="list-style-type: none"> • NO WAITING • ELIMINATES DOWN TIME • MAKES ALL 300 STANDARD O-RINGS AND MANY SPECIALS • INCLUDES SPECIAL RAPID-SET ADHESIVES • INGENIOUS SPLICING NEVER FAILS 	DESCRIPTION
		CONTENTS: 7 feet of each: 3/32", 1/8", 3/16" and 1/4" 1 razor blade, 1 cutting and splicing jig, 1 tube rapid-set adhesive and 4 pieces o-ring Nitrile Buna-N cord stock
		PART
		A 60099

O-RINGS - VITON

VITON COMPOUND

Viton compound for high temperature and chemical resistant applications.



FEATURES:

- BROAD TEMPERATURE RANGE -15°F to +400°F
- EXCELLENT CHEMICAL COMPATIBILITY RESISTS ACIDS, SILICON FLUIDS, SOLVENTS AND OILS
- LOW COMPRESSION SET
- BROWN IN COLOR FOR EASY IDENTIFICATION

RECOMMENDED FOR USE WITH:

- PETROLEUM OILS
- SOLVENTS
- SILICONE FLUIDS AND GREASES
- DIESTER LUBRICANTS
- ACIDS

1/16" THICK

I.D. (A)	O.D. (B)	INDUSTRY#	PART	I.D. (A)	O.D. (B)	INDUSTRY#	PART	I.D. (A)	O.D. (B)	INDUSTRY#	PART
1/32	3/32	001	R 61001	9/16	11/16	015	R 61050	1-1/2	1-5/8	029	R 61060
3/64	9/64	002	R 61040	5/8	3/4	016	R 61051	1-5/8	1-3/4	030	N 61030
1/16	3/16	003	R 61003	11/16	13/16	017	R 61052	1-3/4	1-7/8	031	N 61031
5/64	13/16	004	R 61004	3/4	7/8	018	R 61053	1-7/8	2	032	N 61032
3/32	7/32	005	R 61005	13/16	15/16	019	R 61054	2	2-1/8	033	N 61033
1/8	1/4	006	R 61041	7/8	1	020	R 61055	2-1/8	2-1/4	034	N 61034
5/32	9/32	007	R 61042	15/16	1-1/16	021	R 61056	2-1/4	2-3/8	035	N 61035
3/16	5/16	008	R 61043	1	1-1/8	022	R 61057	2-3/8	2-1/2	036	N 61036
7/32	11/32	009	R 61044	1-1/16	1-3/16	023	R 61058	2-1/2	2-5/8	037	N 61037
1/4	3/8	010	R 61045	1-1/8	1-1/4	024	R 61059	2-5/8	2-3/4	038	E 61038
5/16	7/16	011	R 61046	1-3/16	1-5/16	025	R 65025	2-3/4	2-7/8	039	E 61039
3/8	1/2	012	R 61047	1-1/4	1-3/8	026	R 65026	2-7/8	3	040	E 65040
7/16	9/16	013	R 61048	1-5/16	1-7/16	027	R 61027	3	3-1/8	041	E 65041
1/2	5/8	014	R 61049	1-3/8	1-1/2	028	R 65028	-	-	-	-

3/32" THICK

I.D. (A)	O.D. (B)	INDUSTRY#	PART	I.D. (A)	O.D. (B)	INDUSTRY#	PART	I.D. (A)	O.D. (B)	INDUSTRY#	PART
1/16	1/4	102	R 61102	15/16	1-1/8	119	R 61070	2	2-3/16	136	I 65136
3/32	9/32	103	R 61103	1	1-3/16	120	R 61071	2-1/16	2-1/4	137	I 65137
1/8	5/16	104	R 61104	1-1/16	1-1/4	121	R 61072	2-1/8	2-5/16	138	I 65138
5/32	11/32	105	R 65105	1-1/8	1-5/16	122	R 61073	2-3/16	2-3/8	139	I 65139
3/16	3/8	106	R 65106	1-3/16	1-3/8	123	R 61074	2-1/4	2-7/16	140	I 65140
7/32	13/32	107	R 65107	1-1/4	1-7/16	124	R 61075	2-5/16	2-1/2	141	I 65141
1/4	7/16	108	R 65108	1-5/16	1-1/2	125	N 65125	2-3/8	2-9/16	142	I 65142
5/16	1/2	109	R 65109	1-3/8	1-9/16	126	N 65126	2-7/16	2-5/8	143	I 65143
3/8	9/16	110	R 61061	1-7/16	1-5/8	127	N 65127	2-1/2	2-11/16	144	I 65144
7/16	5/8	111	R 61062	1-1/2	1-11/16	128	N 65128	2-9/16	2-3/4	145	I 65145
1/2	11/16	112	R 61063	1-9/16	1-3/4	129	N 65129	2-5/8	2-13/16	146	I 65146
9/16	3/4	113	R 61064	1-5/8	1-13/16	130	N 65130	2-11/16	2-7/8	147	I 65147
5/8	13/16	114	R 61065	1-11/16	1-7/8	131	N 65131	2-3/4	2-15/16	148	I 65148
11/16	7/8	115	R 61066	1-3/4	1-15/16	132	N 65132	2-13/16	3	149	I 65149
3/4	15/16	116	R 61067	1-13/16	2	133	N 61076	2-7/8	3-1/16	150	I 61150
13/16	1	117	R 61068	1-7/8	2-1/16	134	N 65134	3	3-3/16	151	I 65151
7/8	1-1/16	118	R 61069	1-15/16	2-1/8	135	N 65135	-	-	-	-

O-RINGS - VITON (Cont'd.)

1/8" THICK											
I.D. (A)	O.D. (B)	INDUSTRY#	PART	I.D. (A)	O.D. (B)	INDUSTRY#	PART	I.D. (A)	O.D. (B)	INDUSTRY#	PART
3/16	7/16	201	R 65201	1	1-1/4	214	R 61083	2	2-1/4	226	I 65226
1/4	1/2	202	R 65202	1-1/16	1-5/16	215	R 61084	2-1/8	2-3/8	227	I 65227
5/16	9/16	203	R 65203	1-1/8	1-3/8	216	R 61085	2-1/4	2-1/2	228	I 65228
3/8	5/8	204	R 65204	1-3/16	1-7/16	217	R 61086	2-3/8	2-5/8	229	I 65229
7/16	11/16	205	R 65205	1-1/4	1-1/2	218	R 61087	2-1/2	2-3/4	230	I 65230
1/2	3/4	206	R 65206	1-5/16	1-9/16	219	R 61088	2-5/8	2-7/8	231	I 65231
9/16	13/16	207	R 65207	1-3/8	1-5/8	220	R 61089	2-3/4	3	232	I 65232
5/8	7/8	208	R 61077	1-7/16	1-11/16	221	R 61090	2-7/8	3-1/8	233	I 65233
11/16	15/16	209	R 61078	1-1/2	1-3/4	222	R 61091	3	3-1/4	234	I 65234
3/4	1	210	R 61079	1-5/8	1-7/8	223	R 61092	-	-	-	-
13/16	1-1/16	211	R 61080	1-3/4	2	224	R 61093	-	-	-	-
7/8	1-1/8	212	R 61081	1-7/8	2-1/8	225	R 65225	-	-	-	-
3/16" THICK											
I.D. (A)	O.D. (B)	INDUSTRY#	PART	I.D. (A)	O.D. (B)	INDUSTRY#	PART	I.D. (A)	O.D. (B)	INDUSTRY#	PART
7/16	13/16	309	I 61309	1-1/16	1-7/16	319	I 65319	2	2-3/8	329	E 61329
1/2	7/8	310	I 65310	1-1/8	1-1/2	320	I 65320	2-1/8	2-1/2	330	E 61330
9/16	1/16	311	I 65311	1-3/16	1-9/16	321	I 61321	2-1/4	2-5/8	331	E 61331
5/8	1	312	I 61312	1-1/4	1-5/8	322	I 61322	2-3/8	2-3/4	332	E 61332
11/16	1-1/16	313	I 61313	1-5/16	1-11/16	323	I 61323	2-1/2	2-7/8	333	E 61333
3/4	1-1/8	314	I 61314	1-3/8	1-3/4	324	I 61324	2-5/8	3	334	E 61334
13/16	1-3/16	315	I 61315	1-1/2	1-7/8	325	I 61094	2-3/4	3-1/8	335	E 61335
7/8	1-1/4	316	I 61316	1-5/8	2	326	I 61095	2-7/8	3-1/4	336	E 61336
15/16	1-5/16	317	I 65317	1-3/4	2-1/8	327	I 61096	3	3-3/8	337	E 61337
1	1-3/8	318	I 65318	1-7/8	2-1/4	328	E 61328	-	-	-	-

O-RING COMPATIBILITY CHART

GENERAL PROPERTIES OF O-RING MATERIALS					
	BUNA-N	VITON		BUNA-N	VITON
Temperature Range	-40°F to +300°F	-15°F to +400°F	Compression Set	Good	Good
RESISTANCE TO:			RESISTANCE TO:		
Tearing	Good	Good	Concentrated Alkalies	Good	Excellent
Abrasion	Excellent	Good	Synthetic Lubricants (Silicone Grease)	Good	Excellent
Ozone	Poor	Excellent	High Aniline Lubricants (ASTM Oil #1 or MIL-L-6082)	Excellent	Excellent
Weather	Poor	Excellent	Low Aniline Lubricants (ASTM Oil #3 or MIL-H-5606)	Excellent	Excellent
Cold Water	Excellent	Fair	Animal / Vegetable Oils	Good	Excellent
Hot Water	Good	Poor	Aliphatic Hydrocarbons (Fuel Oil A)	Excellent	Excellent
Steam	Poor	Poor	Aromatic Hydrocarbons (Fuel Oil C or Toluene)	Poor	Excellent
Dilute Acids	Good	Excellent			
Concentrated Acids	Good	Excellent			
Dilute Alkalies	Good	Excellent			

Temperature ranges and chemical compatibility are for general comparisons.

NEEDLE FILES

SWISS PATTERN ROUND HANDLE

For those tight spots and precision filing jobs where regular files cannot reach. Files are all No. 2 x 6-1/4" length.

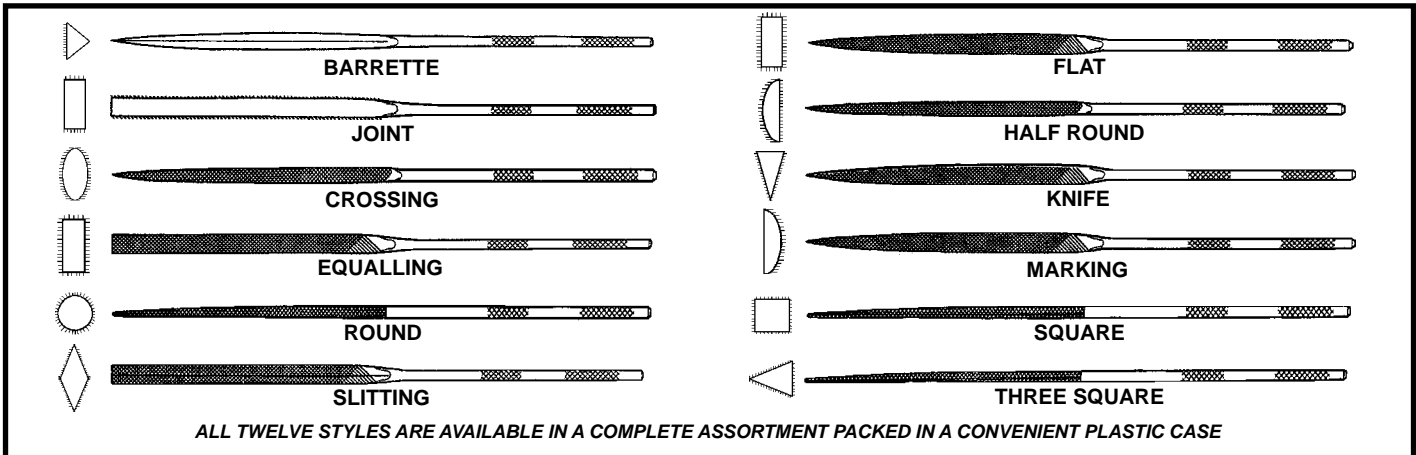

TYPE	PART	TYPE	PART	TYPE	PART	TYPE	PART
Barrette	A 15560	Flat (Warding)	A 15564	Round	A 15568	Needle File Handle	c 15573
Joint (Sq. Edge)	A 15561	Half Round	A 15565	Slitting	A 15569	12-Piece Assortment	A 15572
Crossing	A 15562	Knife	A 15566	Square	A 15570		
Equalling (Hand)	A 15563	Marking	A 15567	Three Square	A 15571		

CIC 200™ RAPID CUT FILES

MILL FILES

LTH.	SIZE	COARSENESS	PART
8"	13/16 x 5/32	Bastard	A 15500
10"	1 x 3/16	Bastard	A 15504

For use in workshops and sharpening mill and circular saws, hoes, axes, spades, shovels, etc. Also for draw filing and finishing metal.

TAPER SAW FILES

LTH.	SIZE	COARSENESS	PART
6"	3/8	Slim	A 15536

For use in hand filing of all types of saws with 60° angle teeth. The single cut edges set and cut for filing gullets between saw teeth.

FLAT FILES

LTH.	SIZE	COARSENESS	PART
8"	13/16 x 7/32	Bastard	A 15508
10"	1 x 1/4	Bastard	A 15512

For use in factories, machine shops, and garages because of its ability to work on iron, steel, etc.; and quick removal of stock from plain surfaces.

SQUARE FILES

LTH.	SIZE	COARSENESS	PART
8"	5/16	Bastard	A 15540

For use in filing grooves, square holes, inside corners and for finishing cutting tools.

ROUND (RAT TAIL) FILES

LTH.	SIZE	COARSENESS	PART
6"	1/4	Bastard	A 15516
8"	5/16	Bastard	A 15520
10"	3/8	Bastard	A 15524

For use in enlarging circular holes, moldings, concave surfaces and rounded grooves.

CHAIN SAW FILES

LTH.	SIZE	COARSENESS	PART
8"	7/32	-	A 15544
8"	3/16	-	A 15548
8"	5/32	-	A 15552

For use in filing saw chain. Also can be used to clean and dress up gullets of some saws.

CIC 200™ RAPID CUT FILES (Cont'd.)

HALF ROUND FILES

Half round side can be used for filing rounded holes, concave corners, crevices, etc. Can also be used on flat surfaces.

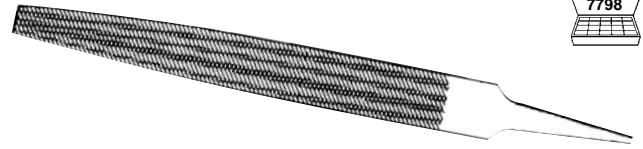

LTH.	SIZE	COARSENESS	PART	
8"	3/4 x 7/32	Bastard	A	15528
10"	15/16 x 9/32	Bastard	A	15532

CIC 200™ RAPID CUT FILE ASSORTMENT

Provides your shop with the most valuable, quality files for all your maintenance and repair needs. Use for sharpening, deburring, beveling, honing, scraping, lathe filing, edging, deflashing, etc.

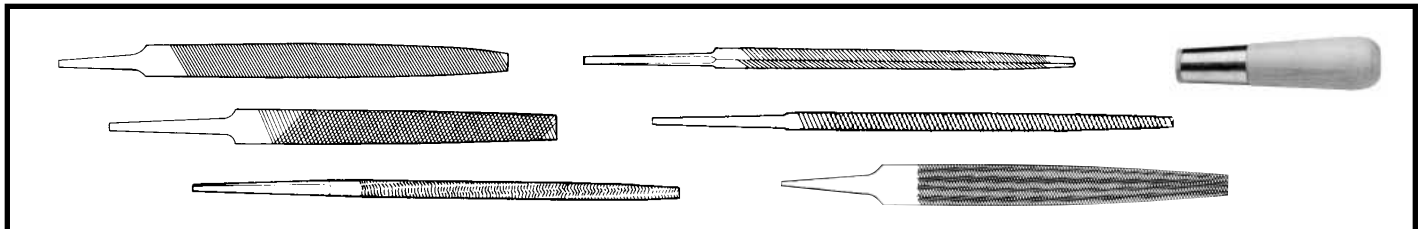

DESCRIPTION	PART
RAPID CUT FILE ASSORTMENT 2 ea. — 8" Mill Bastard, 10" Mill Bastard, 8" Flat Bastard, 6" Round Bastard, 8" Round Bastard, 10" Round Bastard, 6" Slim Taper Saw, 8 x 7/32 Chain Saw, 8 x 3/16 Chain Saw, 8 x 5/32 Chain Saw and Wooden Handles 1 ea. — 10" Flat Bastard, 8" Half-Round Bastard, 10" Half-Round Bastard and 8" Square Bastard	A 7798

WOODEN FILE HANDLES

GREATER SAFETY

- A PROPERLY FITTED HANDLE WILL ENCOURAGE BETTER WORK AND MAKE THE JOB EASIER AND SAFER
- WOOD HANDLES ABSORB HAND MOISTURE MORE READILY FOR EVEN GREATER SAFETY



DESCRIPTION	PART	
4" to 8" Wooden File Handles	D	15553
6" to 10" Wooden File Handles	D	15555
8" to 12" Wooden File Handles	D	15556

BLACK MAXI™ HAND FILES

SUPERIOR DURABILITY AND FASTER CUTTING

BLACK MAXI FILE TRAY ASSORTMENT

- SPECIAL BLACK OXIDE COATING LASTS LONGER, RESISTS LOADING AND RUSTING
- HANDY ASSORTMENT OF THE MOST COMMONLY USED FILES
- ALL FILES COME COMPLETE WITH WOODEN FILE HANDLES
- INCLUDES:
 - 10" FLAT BASTARD
 - 10" HALF ROUND BASTARD
 - 10" ROUND BASTARD
 - 10" MILL BASTARD
 - 9" SQUARE BASTARD
 - 10" FLAT SMOOTH
 - 7" SLIM TAPER
 - FILE CARD



DESCRIPTION	PART
Metal Tray Assortment	A 17841T

MILL

- FOR USE IN SHARPENING, DRAW FILING, LATHE WORK AND GENERAL SHOP USE
- SINGLE CUT ON THE SIDES AND EDGES, TAPER TOWARD THE POINT IN WIDTH



LENGTH	SIZE	COARSENESS	PART
8"	13/16 x 5/32	Bastard	A 15580
10"	1 x 3/16	Bastard	A 15581

TAPER SAW

- DESIGNED FOR FILING ALL TYPES OF SAWS WITH 60° ANGLE TEETH
- TRIANGULAR IN SHAPE, HAVE CUT EDGES AND TAPER TOWARD THE POINT IN WIDTH AND THICKNESS



LENGTH	SIZE	COARSENESS	PART
6"	3/8	Slim	A 15537
7"	3/8	Double Extra Slim	A 15538

THREE SQUARE

- EXCELLENT FOR CLEANING OUT CORNERS OR FOR USE ON CUTTERS, TAPS & FLAT SURFACES
- DOUBLE CUT AND TAPER TOWARD THE POINT IN WIDTH AND THICKNESS
- EXCLUSIVE "WAVY TOOTH" DESIGN



LENGTH	SIZE	COARSENESS	PART
6"	5/16	Bastard	A 15541
8"	3/8	Bastard	A 15542

FLAT

- EXCELLENT FOR "HOGGING" OR RAPID STOCK REMOVAL
- DOUBLE CUT ON BOTH SIDES, SINGLE CUT ON EDGES AND TAPER TOWARD THE POINT IN WIDTH





LENGTH	SIZE	COARSENESS	PART
8"	13/16 x 7/32	Bastard	A 15582
10"	1 x 1/4	Bastard	A 15583
10"	1 x 1/4	Smooth	A 15584

BLACK MAXI™ HAND FILES (Cont'd)

ROUND (RAT TAIL)



- INTENDED FOR ENLARGING AND ROUNDING OUT CIRCULAR OPENINGS OR CONCAVE SURFACES
- DOUBLE CUT AND TAPER TOWARD THE POINT IN WIDTH AND THICKNESS

LENGTH	SIZE	COARSENESS	PART	
6"	1/4	Bastard	A	15585
8"	15/16	Bastard	A	15586
10"	3/8	Bastard	A	15587

HALF ROUND



- USE FOR ROUNDING OUT HOLES, CORNERS AND CREVICES
- DOUBLE CUT ON BOTH SIDES AND TAPER TOWARD THE POINT IN WIDTH AND THICKNESS

LENGTH	SIZE	COARSENESS	PART	
8"	5/16	Bastard	A	15590
10"	15/16	Bastard	A	15591

FLAT MULTI-CUT



- OBTAIN ALMOST ANY REQUIRED FINISH SIMPLY BY CHANGING THE FEED PRESSURE
- SINGLE CUT COARSE TOOTH FILES THAT TAPER TOWARD THE POINT IN WIDTH
- DESIGN FEATURES A DIAMOND PATTERN "DOUBLE CHIP-BREAKER" ALLOWING FOR FAST REMOVAL WHILE LEAVING A SMOOTH FINISH

LENGTH	SIZE	COARSENESS	PART	
8"	7/32	–	A	15550
10"	3/16	–	A	15554

ALL-PURPOSE



- BUILT-IN HANDLE PROVIDES MAXIMUM VERSATILITY FOR A WIDE RANGE OF APPLICATIONS
- DOUBLE CUT ON ONE SIDE, SINGLE CUT ON THE OTHER
- HAS ONE EDGE CUT AND ONE EDGE SAFE (UNCUT) FOR SHOULDER FILING AND IS PARALLEL IN WIDTH AND THICKNESS

LENGTH	SIZE	COARSENESS	PART	
10"	1/4	Bastard	A	15546

FILE CARD

- FILES LAST LONGER WHEN KEPT PROPERLY CLEANED WITH FILE CARDS
- EXCESS BUILD-UP CAUSES CLOGGING RESULTING IN SLIPPING, SCRATCHING OR OTHER FILING INEFFICIENCIES





DESCRIPTION	PART	
File Card	A	15588

CIC 200™ CARBIDE ROTARY FILES

SOLID CARBIDE WITH 1/4" SHANK

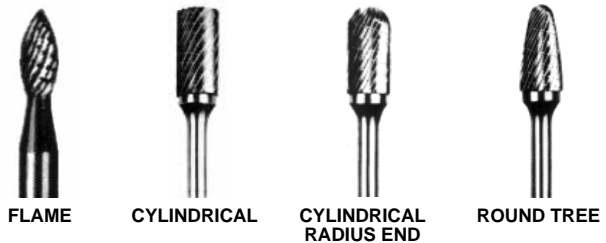
- MANUFACTURED FROM C2 GRADE CARBIDE FOR HIGH PERFORMANCE METAL REMOVAL
- PRECISION MANUFACTURING PROCESS DELIVERS DEPENDABLE REPEATABILITY, BUR AFTER BUR
- REDUCED PULLING FOR BETTER OPERATOR CONTROL
- ROCKWELL "C" 91.8
- IDEAL FOR USE ON ALL STEELS, IRON, MASONITE, FIBERGLASS, WELDMENTS AND TITANIUM ALLOY



DOUBLE CUT FLUTES:

- IDEAL FOR RAPID STOCK METAL REMOVAL
- SMALLER, FINER CHIPS FOR EASIER DISPOSAL

FAST MILL CUT FLUTES:

- DESIGNED TO REDUCE LOADING WHILE PROVIDING RAPID STOCK REMOVAL
- RECOMMENDED FOR ALUMINUM AND OTHER NON-FERROUS METALS



SPECIFICATIONS

SHAPE	DIAMETER	LENGTH OF FLUTE	INDUSTRY TYPE	DOUBLE CUT P/N	FAST MILL CUT P/N	FAST MILL CUT 6" SHAFT P/N
CYLINDRICAL	1/4"	5/8"	SA-1	B 34003	—	—
CYLINDRICAL	3/8"	3/4"	SA-3	B 34007	—	—
CYLINDRICAL	1/2"	1"	SA-5	A 34011	A 34211	—
CYLINDRICAL RADIUS END	1/4"	5/8"	SC-1	B 34033	—	—
CYLINDRICAL RADIUS END	3/8"	3/4"	SC-3	A 34037	A 34237	—
CYLINDRICAL RADIUS END	1/2"	1"	SC-5	A 34041	—	—
ROUND TREE	1/4"	5/8"	SF-1	B 34045	A 34245	—
ROUND TREE	3/8"	3/4"	SF-3	A 34047	A 34247	—
ROUND TREE	1/2"	1"	SF-5	A 34050	A 34250	—
POINTED TREE	1/4"	5/8"	SG-1	B 34055	—	—
POINTED TREE	3/8"	3/4"	SG-3	A 34058	—	—
POINTED TREE	1/2"	1"	SG-5	A 34060	—	—
OVAL	1/4"	3/8"	SE-1	B 34065	—	—
OVAL	3/8"	5/8"	SE-3	A 34066	A 34266	A 34666
OVAL	1/2"	7/8"	SE-5	A 34067	A 34267	A 34667
BALL	1/4"	1/4"	SD-1	B 34072	—	—
BALL	3/8"	3/8"	SD-3	B 34074	—	—
BALL	1/2"	1/2"	SD-5	A 34076	A 34276	—
CONE	1/4"	1/2"	SM-1	B 34080	—	—
CONE	1/4"	1"	SM-3	A 34082	—	—
CONE	3/8"	5/8"	SM-4	A 34085	—	—
CONE	1/2"	7/8"	SM-5	A 34087	—	—
14° TAPER-RADIUS END	1/4"	5/8"	SL-1	A 34089	—	—
14° TAPER-RADIUS END	3/8"	1-1/16"	SL-3	A 34091	A 34291	—
14° TAPER-RADIUS END	1/2"	1-1/8"	SL-4	A 34092	A 34292	—
FLAME	5/16"	3/4"	SH-2	A 34099	A 34299	—
FLAME	1/2"	1-1/4"	SH-5	—	A 34300	A 34600

8-PC. CARBIDE ROTARY FILE INDEX



CONTENTS

DOUBLE CUT: Cylindrical 1/4" x 5/8", Cylindrical Round End 1/4" x 5/8", Round Tree 1/2" x 1", Pointed Tree 3/8" x 3/4", Oval 1/2" x 7/8", Ball 1/4" x 1/4", Cone 1/2" x 7/8" and Taper Radius 1/2" x 1-1/8"

FAST MILL CUT: Cylindrical 1/2" x 1", Cylindrical Round End 3/8" x 3/4", Round Tree 1/2" x 1", Oval 3/8" x 5/8", Oval 1/2" x 7/8", Ball 1/2" x 1/2", Taper Radius 1/2" x 1-1/8" and Flame 5/16" x 3/4"

PART

A 61604

A 61626

CIC 200™ MINIATURE CARBIDE ROTARY FILES

SOLID CARBIDE WITH 1/8" SHANK

- **MANUFACTURED FROM C2 GRADE CARBIDE**
FOR HIGH PERFORMANCE METAL REMOVAL
- **PRECISION MANUFACTURING PROCESS**
DELIVERS DEPENDABLE REPEATABILITY, BUR AFTER BUR
- **DOUBLE CUT FLUTES**
FOR RAPID METAL REMOVAL
- **SMALLER, FINER CHIPS**
FOR EASIER DISPOSAL
- **REDUCED PULLING**
FOR BETTER OPERATOR CONTROL
- **ROCKWELL "C" 91.8**
- **IDEAL FOR USE ON**
ALL STEELS, IRON, MASONITE,
FIBERGLASS, WELDMENTS
AND TITANIUM ALLOYS

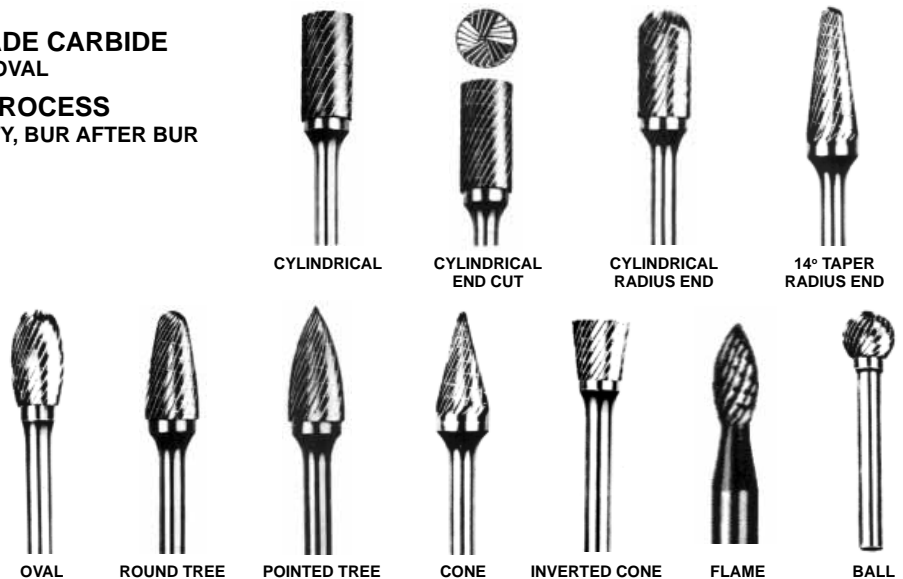

SPECIFICATIONS

SHAPE	HEAD DIA.	LENGTH OF FLUTE	INDUSTRY TYPE	PART
CYLINDRICAL	1/4"	1/2"	SA-51	B 34100
CYLINDRICAL END CUT	1/4"	3/16"	SB-51	B 34101
CYLINDRICAL RADIUS END	1/4"	1/2"	SC-51	B 34102
BALL	1/4"	1/4"	SD-51	B 34103
OVAL	1/4"	3/8"	SE-51	B 34104
ROUND TREE	1/4"	1/2"	SF-51	B 34105
POINTED TREE	1/4"	1/2"	SG-51	B 34106
CONE	1/4"	1/2" — 22°	SM-51	B 34107
INVERTED CONE	1/4"	1/4" — 10°	SN-51	B 34108
CYLINDRICAL	1/8"	9/16"	SA-43	D 34109
CYLINDRICAL RADIUS END	1/8"	9/16"	SC-42	D 34110
BALL	1/8"	1/8"	SD-42	D 34111
OVAL	1/8"	1/4"	SE-41	D 34112
ROUND TREE	1/8"	1/2"	SF-42	D 34113
POINTED TREE	1/8"	1/2"	SG-44	D 34114
FLAME	1/8"	1/4"	SH-41	D 34115
CONE	1/8"	11/32" — 12° incl. taper	SM-41	D 34116

7-PC. MINIATURE CARBIDE ROTARY FILE INDEX

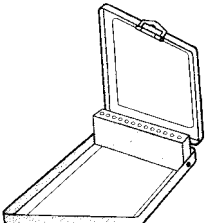
CONTENTS	PART
<p>Contains 7 pieces:</p> <ul style="list-style-type: none"> • Cylindrical 1/4" x 1/2" • Cylindrical Radius End 1/4" x 1/2" • Ball 1/4" x 1/4", Oval 1/4" x 3/8" • Round Tree 1/4" x 1/2" • Pointed Tree 1/4" x 1/2" • Cone 1/4" x 1/2" 	 <p>A 61606</p>

TITANIUM NITRIDE COATED CARBIDE BURS

MANUFACTURED IN THE U.S.A. FROM C2 TUNGSTEN CARBIDE

Features

- Manufactured in the U.S.A. from C2 tungsten carbide.
- TiN carbide burs are precision machine ground using diamond wheels and automated CNC machinery.
- Producing consistent geometry, sharp cutting edges and vibration free performance.
- All burs are Titanium Nitride coated for superior surface finish and long life.
- Types Available
 - Double-cut Burs
 - Bur Sets

Application

- TiN Carbide Burs are one of the most versatile metal working tools.
- Used in virtually every industry, burs are used in mold and pattern making, die sinking, tool making, and maintenance.

Uses

- They are used widely in these industries:
 - Automotive
 - Aerospace
 - Foundry
 - Power station
 - Engineering

Bur Types

Double-Cut

- Double-cut burs have a primary and secondary cutting edge
- The primary cutting edge does the majority of cutting, while the secondary cutting edge breaks the chips into smaller pieces which are easily disposed of
- Produces a very smooth work piece finish

Vacuum brazing

- The braze is copper, done via induction coil process
- Very strong
- Results in a safe bur
- Will not lose its head under normal use
Note: These are spinning in excess of 20,000 rpm.

Usage Guidelines

- Do not use carbide burs in portable drill motors. Portable drill motors run at much lower speeds.

Operating Speed Recommendations

- Slower speeds for harder materials
- Higher speeds when using small burs
- Slower speeds when using long series burs

Cautions

- Running burs below recommended speeds may cause chipping.
- Do not use worn-out tools and collets. They will cause chipping.
- Running burs too fast will cause teeth to wear prematurely.
- Apply constant pressure and steady action.

APPLICATION AND SPEED RECOMMENDATIONS

SOLID CARBIDE BUR APPLICATION INFORMATION			SOLID CARBIDE BUR SPEED RECOMMENDATIONS		
MATERIAL Check List	SUITABILITY		BUR DIAMETER	Recommended Cutting Speed (RPM)	Maximum Cutting Speed (RPM)
	Double Cut	Non-Ferrous			
Aluminum	—	✓	1/16	60,000 - 90,000	100,000
Brass	✓	✓	1/8	40,000 - 70,000	90,000
Bronze	✓	—	3/16	35,000 - 60,000	80,000
Cast Iron	✓	—	1/4	30,000 - 50,000	70,000
Copper	—	✓	5/16	20,000 - 40,000	68,000
Carbon Fiber	—	✓	3/8	20,000 - 40,000	66,000
Fiberglass	✓	—	7/16	15,000 - 40,000	58,000
Inconel	✓	—	1/2	15,000 - 40,000	50,000
Magnesium	—	✓	5/8	12,000 - 25,000	40,000
Plastics	✓	—	3/4	10,000 - 20,000	33,000
Hard Rubber	✓	—	1	7,500 - 20,000	25,000
Steel - 45-55Rc	✓	—	1-1/8	7,000 - 13,000	20,000
Steel - 55-60Rc	✓	—	1-1/2	5,000 - 10,000	17,000
Steel - Carbon	✓	—	1-3/4	4,500 - 9,000	14,000
Steel - Nickel Chrome	✓	—	2	4,000 - 8,000	12,500
Steel - Stainless	✓	—			
Steel - Weldments	✓	—			
Titanium	✓	—			
Zinc	—	✓			

TITANIUM NITRIDE COATED CARBIDE BURS

MANUFACTURED IN THE U.S.A. FROM C2 TUNGSTEN CARBIDE

8 Piece Set

P/N 63600

Includes the following:

- Cylinder Radius End SC1 P/N 34399
- Ball Shape SD1 P/N 34423
- Cylinder Shape SA3 P/N 34359
- Cylinder Radius End SC3 P/N 34404
- Tree Shape Radius End SF3 P/N 34458
- Ball Shape SD3 P/N 34427
- Cylinder Shape SA5 P/N 34365
- Tree Shape Radius End SF5 P/N 34463

Note: The application of Titanium Nitride to Chromate cutting tools is performed via physical vapor deposition process. This gives the cutting tool a bright gold color. Occasionally this process results in the discoloration of the tool shank, which has no negative effect on the tool's performance.

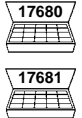

SA - Cylinder Shape

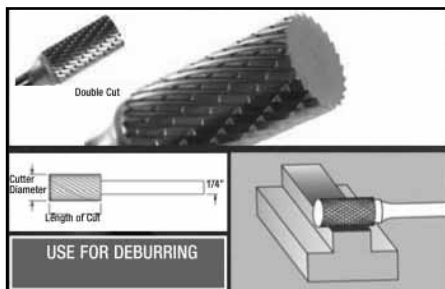

P/N	Industry Type	Cutter Diameter	Length of Cut
34350	A SA11	1/8	1/2
34351	A SA12	1/8	5/8
34352	A SA13	5/32	5/8
34353	A SA14	3/16	5/8
34354	A SA1	1/4	5/8
34355	A SA1L	1/4	7/8
34358	A SA2	5/16	3/4
34359	A SA3	3/8	3/4
34362	A SA3L	3/8	1
34363	A SA3X	3/8	1-1/2
34364	A SA4	7/16	1
34365	A SA5	1/2	1
34368	A SA6	5/8	1
34370	A SA15	3/4	1/2
34371	A SA16	3/4	1/2
34372	A SA7	3/4	1
34375	A SA8	7/8	1
34376	A SA9	1	1

SB - Cylinder End Cut

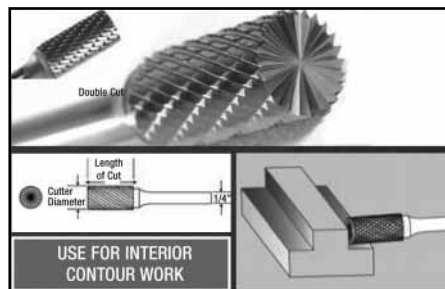

P/N	Industry Type	Cutter Diameter	Length of Cut
34377	A SB11	1/8	1/2
34378	A SB12	1/2	5/8
34379	A SB13	5/32	5/8
34380	A SB14	3/16	5/8
34381	A SB1	1/4	5/8
34382	A SB1L	1/4	1
34383	A SB2	5/16	3/4
34384	A SB3	3/8	3/4
34385	A SB3L	3/8	1
34386	A SB3X	3/8	1-1/2
34387	A SB4	7/16	1
34388	A SB5	1/2	1
34389	A SB6	5/8	1
34390	A SB15	3/4	1/2
34391	A SB16	3/4	3/4
34392	A SB7	3/4	1
34393	A SB8	7/8	1
34394	A SB9	1	1

SC - Cylinder Radius End

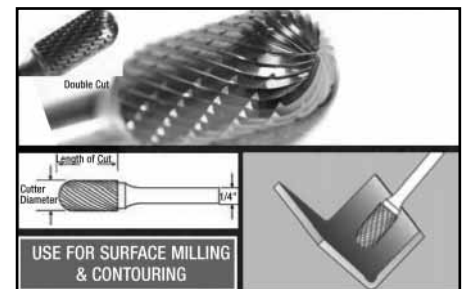

P/N	Industry Type	Cutter Diameter	Length of Cut
34395	A SC11	1/8	1/2
34396	A SC12	1/8	5/8
34397	A SC13	5/32	5/8
34398	A SC14	3/16	5/8
34399	A SC1	1/4	5/8
34400	A SC1L	1/4	7/8
34403	A SC2	5/16	3/4
34404	A SC3	3/8	3/4
34407	A SC3L	3/8	1
34408	A SC3X	3/8	1-1/2
34409	A SC4	7/16	1
34410	A SC5	1/2	1
34413	A SC6	5/8	1
34415	A SC15	3/4	1/2
34416	A SC16	3/4	3/4
34417	A SC7	3/4	1
34420	A SC9	1	1

Bold italic text = Non-stock item. Please allow 4-6 weeks for delivery.

Bold italic text = Non-stock item. Please allow 4-6 weeks for delivery.

Bold italic text = Non-stock item. Please allow 4-6 weeks for delivery.

TITANIUM NITRIDE COATED CARBIDE BURS

MANUFACTURED IN THE U.S.A. FROM C2 TUNGSTEN CARBIDE

SD - Ball Shape



P/N	Industry Type	Cutter Diameter	Length of Cut
34421	A SD11	1/8	3/32
34422	A SD14	3/16	1/8
34423	A SD1	1/4	7/32
34426	A SD2	5/16	1/4
34427	A SD3	3/8	5/16
34430	A SD4	7/16	3/8
34431	A SD5	1/2	7/16
34434	A SD6	5/8	9/16
34436	A SD7	3/4	11/16
34439	A SD9	1	15/16

34421, 34422, 34426, 34430, 34434, 34436, 34439 = Non-stock item. Please allow 4-6 weeks for delivery.

SE - Oval Shape

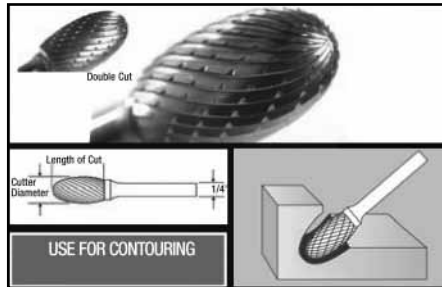

P/N	Industry Type	Cutter Diameter	Length of Cut
34440	A SE11	3/16	5/16
34441	A SE1	1/4	3/8
34443	A SE3	3/8	5/8
34446	A SE5	1/2	7/8
34449	A SE6	5/8	1
34451	A SE7	3/4	1

34440, 34449, 34451 = Non-stock item. Please allow 4-6 weeks for delivery.

SF - Tree Shape Radius End

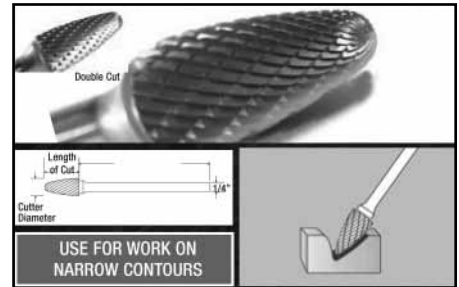

P/N	Industry Type	Cutter Diameter	Length of Cut
34454	A SF11	1/8	1/2
34455	A SF1	1/4	3/4
34458	A SF3	3/8	3/4
34461	A SF4	7/16	1
34462	A SF13	1/2	3/4
34463	A SF5	1/2	1
34466	A SF6	5/8	1
34468	A SF7	3/4	1
34469	A SF14	3/4	1-1/4
34472	A SF15	3/4	1-1/2

34454, 34461, 34462, 34466, 34468, 34469, 34472 = Non-stock item. Please allow 4-6 weeks for delivery.

SG - Tree Shape

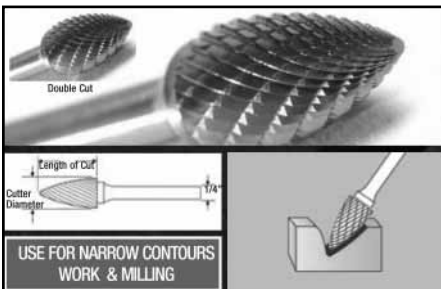

P/N	Industry Type	Cutter Diameter	Length of Cut
34473	A SG1	1/4	5/8
34475	A SG2	5/16	3/4
34476	A SG3	3/8	3/4
34478	A SG13	1/2	3/4
34479	A SG5	1/2	1
34481	A SG6	5/8	1
34482	A SG7	3/4	1
34483	A SG15	3/4	1-1/2

34475, 34478, 34481, 34482, 34483 = Non-stock item. Please allow 4-6 weeks for delivery.

SH - Flame Shape

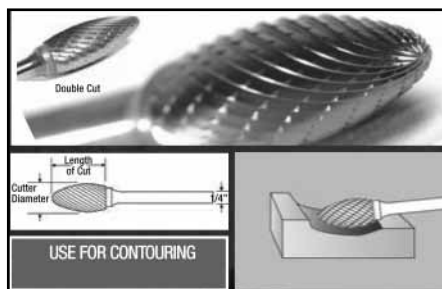

P/N	Industry Type	Cutter Diameter	Length of Cut
34484	A SH1	1/4	5/8
34485	A SH2	5/16	3/4
34487	A SH5	1/2	1-1/4
34489	A SH6	5/8	1-7/16
34490	A SH7	3/4	1-5/8

34484, 34485, 34487, 34489, 34490 = Non-stock item. Please allow 4-6 weeks for delivery.

SL - 14° Taper Radius End

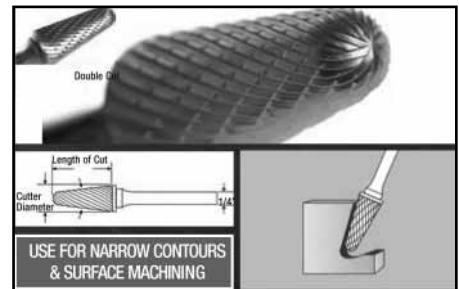

P/N	Industry Type	Cutter Diameter	Length of Cut
34491	A SL1	1/4	5/8
34493	A SL2	5/16	7/8
34494	A SL3	3/8	1-1/16
34497	A SL4	1/2	1-1/8
34500	A SL5	5/8	1-3/16
34502	A SL6	5/8	1-5/16
34504	A SL7	3/4	1-1/2

34493, 34500, 34502, 34504 = Non-stock item. Please allow 4-6 weeks for delivery.

TITANIUM NITRIDE COATED CARBIDE BURS

MANUFACTURED IN THE U.S.A. FROM C2 TUNGSTEN CARBIDE

SM - Cone Shape

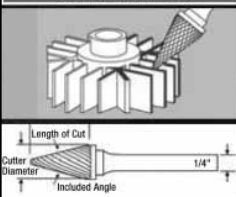

P/N	Industry Type	Cutter Diameter	Length of Cut	USE FOR NARROW CONTOURS / SURFACE MACHINING
<i>34507</i>	A <i>SM1</i>	<i>1/4</i>	<i>1/2</i>	
<i>34508</i>	A <i>SM2</i>	<i>1/4</i>	<i>3/4</i>	
<i>34509</i>	A <i>SM3</i>	<i>1/4</i>	<i>1</i>	
<i>34510</i>	A <i>SM4</i>	<i>3/8</i>	<i>5/8</i>	
<i>34511</i>	A <i>SM5</i>	<i>1/2</i>	<i>7/8</i>	
<i>34512</i>	A <i>SM6</i>	<i>5/8</i>	<i>1</i>	

Length of Cut
Cutter Diameter
Included Angle

34507 - *34512* = Non-stock item. Please allow 4-6 weeks for delivery.

SN - Inverted Cone Shape

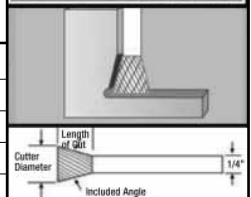

P/N	Industry Type	Cutter Diameter	Length of Cut	EDGE MACHINING FROM THE REAR IN HARD TO REACH AREAS
<i>34513</i>	A <i>SN1</i>	<i>1/4</i>	<i>5/16</i>	
<i>34514</i>	A <i>SN2</i>	<i>3/8</i>	<i>3/8</i>	
<i>34515</i>	A <i>SN4</i>	<i>1/2</i>	<i>1/2</i>	
<i>34516</i>	A <i>SN6</i>	<i>5/8</i>	<i>3/4</i>	
<i>34517</i>	A <i>SN7</i>	<i>3/4</i>	<i>5/8</i>	

Length of Cut
Cutter Diameter
Included Angle

34513 - *34517* = Non-stock item. Please allow 4-6 weeks for delivery.

SK - 90° Cone Shape

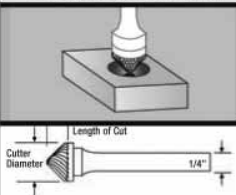

P/N	Industry Type	Cutter Diameter	Length of Cut	MACHINING OF ACUTE ANGLE AREAS / COUNTERSINKING
<i>34518</i>	A <i>SK1</i>	<i>1/4</i>	<i>1/8</i>	
<i>34519</i>	A <i>SK3</i>	<i>3/8</i>	<i>3/16</i>	
<i>34520</i>	A <i>SK5</i>	<i>1/2</i>	<i>1/4</i>	
<i>34521</i>	A <i>SK6</i>	<i>5/8</i>	<i>5/16</i>	
<i>34522</i>	A <i>SK7</i>	<i>3/4</i>	<i>3/8</i>	
<i>34523</i>	A <i>SK9</i>	<i>1</i>	<i>1/2</i>	

Length of Cut
Cutter Diameter
Included Angle

34518 - *34523* = Non-stock item. Please allow 4-6 weeks for delivery.

SJ - 60° Cone Shape

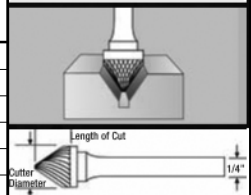

P/N	Industry Type	Cutter Diameter	Length of Cut	MACHINING OF ACUTE ANGLE AREAS / COUNTERSINKING
<i>34524</i>	A <i>SJ1</i>	<i>1/4</i>	<i>3/16</i>	
<i>34525</i>	A <i>SJ3</i>	<i>3/8</i>	<i>5/16</i>	
<i>34526</i>	A <i>SJ5</i>	<i>1/2</i>	<i>7/16</i>	
<i>34527</i>	A <i>SJ6</i>	<i>5/8</i>	<i>9/16</i>	
<i>34528</i>	A <i>SJ7</i>	<i>3/4</i>	<i>11/16</i>	
<i>34529</i>	A <i>SJ9</i>	<i>1</i>	<i>15/16</i>	

Length of Cut
Cutter Diameter
Included Angle

34524 - *34529* = Non-stock item. Please allow 4-6 weeks for delivery.

ABRASIVES

QUICK-LOK™ ABRASIVES

Fast, efficient deburring, blending, finishing and polishing on all types of metals and composites. Just a half twist and they're securely locked in place; a half twist again and it's off. Ideal for use with air tools & flex-shaft grinders.

BRISTLE BRUSHES / DISCS

IDEAL FOR:

- CLEANING
- FINISHING
- BLENDING
- DEBURRING

USE ON:

- CORNERS
- WELDS
- OTHER AREAS WHERE EXTRA CONFORMABILITY IS REQUIRED

USE FOR:

- CLEANING RIVETS, WELDS AND CORNERS



- 50 GRIT - GREEN
- 80 GRIT - YELLOW
- 120 GRIT - WHITE

SIZE	MAX RPM	PART
1" x 50 Grit - Green	30,000	B 45689
1" x 80 Grit - Yellow	30,000	B 45694
1" x 120 Grit - White	25,000	B 45696
2" x 50 Grit - Green	25,000	B 45690
2" x 80 Grit - Yellow	25,000	B 45692
2" x 120 Grit - White	25,000	B 45697
3" x 50 Grit - Green	18,000	B 45691
3" x 80 Grit - Yellow	18,000	B 45693
3" x 120 Grit - White	25,000	B 45698
4.5" x 50 Grit - Green	12,000	A 45703
4.5" x 80 Grit - Yellow	12,000	A 45704
4.5" x 120 Grit - White	12,000	A 45705
Radial Versions		
3" x 3/8 x 50 Grit - Green	25,000	B 45720
3" x 3/8 x 80 Grit - Yellow	25,000	B 45721
3" x 3/8 x 120 Grit - White	25,000	B 45722

ABRASIVE DISCS



Color-coded disc buttons for easy grade identification:
Brown = 36 Orange = 60 White = 120

PREMIUM ALUMINUM OXIDE MINERALS ON DURABLE RESIN BOND AND FIBRE BACKING

GRIT	2" DIA	3" DIA	4" DIA
36	L 45655	I 45661	I 45667
60	L 45657	I 45663	I 45669
120	L 45660	I 45666	I 45672

MINI FLAP DISCS



- HIGH QUALITY ZIRCONIUM EFFECTIVE ON MATERIALS FROM MILD STEEL TO EXOTIC TITANIUM ALLOYS, COMPOSITES & PLASTICS
- COMBINES GRINDING & FINISHING IN 1 STEP
- ALLOWS ACCESS TO TIGHT AREAS

GRIT	2" DIA	3" DIA
40	C 33937	C 33943
80	C 33939	C 33945
120	C 33941	C 33946

THREADED SHAFT AND BACK-UP PADS

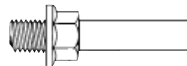

1/4" THREADED SHAFT



BACK-UP PAD

SIZE	MAX RPM	PART
1" Dia.	30,000	A 45634
2" Dia.	25,000	A 45638
3" Dia.	18,000	A 45642
4" Dia.	12,000	A 45644
1/4" Threaded Shaft		A 45630

STRIPPING DISCS

- EXTRA-COURSE DISCS ARE CONSTRUCTED FROM AN OPEN, NON-LOADING WEB
- MAKES TOUGH CLEANING AND STRIPPING JOBS QUICK AND EASY
- CLEANS FASTER AND SAFER THAN WIRE BRUSHES



2" DIA	3" DIA	4" DIA
E 45617	E 45618	E 45619

SURFACE COND. DISCS

- NON-WOVEN NYLON IMPREGNATED WITH ABRASIVE PARTICLES
- PROVIDES A BUR-FREE SURFACE
- SUITABLE FOR PAINTING OR COATING
- IDEAL FOR RUST, OXIDE AND COATING REMOVAL



Very Fine (VFN) = Blue
Medium = Maroon
Coarse = Brown



DIA.	VFN	MEDIUM	COARSE
2"	L 45683	L 45681	L 45682
3"	L 45684	I 45685	I 45686
4"	-	I 45687	I 45688

ABRASIVES

QUICK-LOK™ ABRASIVES

Fast, efficient deburring, blending, finishing and polishing on all types of metals and composites. Just a half twist and they're securely locked in place; a half twist again and it's off. Ideal for use with air tools & flex-shaft grinders.

3M™ CERAMIC CLOSED COAT ABRASIVE GRAIN ROLOC™ DISCS

Premium 3M™ Ceramic Closed Coat Abrasive Grain Roloc™ Discs are constructed on a YN weight, with a durable water resistant polyester cloth backing. Resin bonded for heat resistance. 3M™ Roloc™ Discs provide a fast, efficient method for grinding, blending, leveling and finishing on all types of metal. Each disc is color coded by grade.*

- Long life
- Fast cutting
- 100% ceramic mineral
- Can be run wet or dry

* Grade	3M™ Roloc™ Disc Button Color
24	Black
36	Brown
60	Orange
80	Yellow
120	White

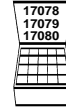

DESCRIPTION	GRADE (GRIT)	PART	DESCRIPTION	GRADE (GRIT)	PART
3" Roloc™ Discs	24	I 45605	2" Roloc™ Discs	60	L 45602
2" Roloc™ Discs	24	L 45600	3" Roloc™ Discs	80	I 45608
3" Roloc™ Discs	36	I 45606	2" Roloc™ Discs	80	L 45603
2" Roloc™ Discs	36	L 45601	3" Roloc™ Discs	120	I 45609
3" Roloc™ Discs	60	I 45607	2" Roloc™ Discs	120	L 45604

PRESSURE SENSITIVE ADHESIVE (PSA) DISCS

Chromate abrasive tools only use premium abrasive grains. Whether sanding or grinding wood, plastics, metals or polishing to a required finish, Chromate has the abrasive substrate to efficiently finish the job.

- Packaged in roll form for convenient use
- Stick-on paper disc holders
- Cost effective for sanding materials that load
- Semi-open coat with load-resistant size coat for aggressive cutting action
- For edge breaking, surface blending
- For grinding and stock removal



DESCRIPTION	GRIT	PART	DESCRIPTION	GRIT	PART
6" PSA Gold	80	T 45712	6" PSA Gold	220	T 45717
6" PSA Gold	100	T 45713	6" PSA Gold	240	T 45718
6" PSA Gold	120	T 45714	6" PSA Gold	320	T 45719
6" PSA Gold	150	T 45715	6" PSA Stick-on Holder	–	A 45710
6" PSA Gold	180	T 45716			

BENCH AND PEDESTAL GRINDING WHEELS

- QUALITY AND RELIABILITY FOR GENERAL BENCH GRINDING
- FOR ALL TYPES OF STEEL
- INCLUDES ADAPTERS TO FIT VARIOUS GRINDING MACHINES

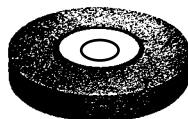

IMPORTANT: All Wheels are manufactured under rigid quality conditions to insure product strength and safety. However, approved guards must be used for operator protection (ANSI Code B7.1).

SIZE	MAX. R.P.M.	ADAPTERS	PART	SIZE	MAX. R.P.M.	ADAPTERS	PART
6 x 3/4 x 1	4,140	1/2, 5/8, 3/4	A 33830	8 x 1 x 1	3,600	5/8, 3/4, 7/8	A 33834
7 x 1 x 1	3,600	1/2, 5/8, 3/4	A 33832	–	–	–	–

ABRASIVES

CIC 200™ RAPID CUT WHEELS

RAISED HUB ABRASIVE WHEELS

ALUMINUM OXIDE ABRASIVE WITH REINFORCED RESINOID BONDING TO INSURE QUALITY, FAST CUTTING AND LONG LIFE IN EVERY WHEEL. THE PERFECT CHOICE FOR:

- GRINDING AND SMOOTHING WELD SEAMS
- CLEANING METAL SURFACES BEFORE WELDING
- METAL CLEAN-UP PRIOR TO PAINTING
- USE ON AIR OR ELECTRIC POWERED, RIGHT ANGLE OR VERTICAL SHAFT GRINDERS
- ALUMINUM OXIDE MEDIUM (60 GRIT)

P/Ns 33800, 33803, 33805
33816, 33817 w/o Connection

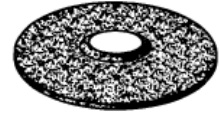
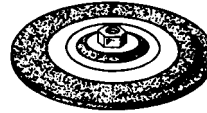

SIZE	MAX. R.P.M.	PART	SIZE	MAX. R.P.M.	PART	SIZE	MAX. R.P.M.	PART
3 x 1/4 x 3/8	20,400	F 33880	4-1/2 x 1/4 x 5/8-11	13,580	B 33817	7 x 1/4 x 5/8-11	8,500	B 33800
4 x 1/8 x 5/8	15,280	F 33898	4-1/2 x 1/4 x 7/8	12,000	F 33899	7 x 1/4 x 7/8	8,500	B 33802
4 x 1/4 x 5/8	15,280	D 33815	7 x 1/16 x 5/8-11	8,500	B 33803	9 x 1/4 x 5/8-11	6,600	B 33805
4-1/2 x 1/16 x 7/8	13,580	D 33814	7 x 1/16 x 7/8	8,500	B 33804	9 x 1/4 x 7/8	6,600	B 33810
4-1/2 x 1/16 x 5/8-11	13,580	B 33816	-	-	-	-	-	-

CUT-OFF WHEELS

HIGH SPEED CUT-OFF WHEELS

- WHEELS TO 4" DIAMETER
- MANUFACTURED WITH ZIRCONIUM ALUMINUM FOR LONGER LIFE.

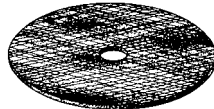

D.M. = DIAMOND MOUNT ARBOR

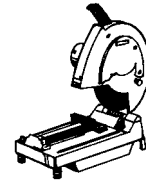
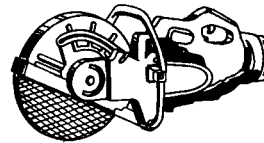

SIZE	MAX R.P.M.	PART	SIZE	MAX R.P.M.	PART	SIZE	MAX R.P.M.	PART
1 x 1/32 x 1/4	61,100	F 33856	3 x 1/16 x 1/4	20,375	F 33872	4 x 1/8 x 1/4	15,280	F 33892
1 x 1/16 x 1/4	61,100	F 33858	3 x 1/16 x 3/8	20,375	F 33874	4 x 1/8 x 3/8	15,280	F 33894
2 x 1/32 x 1/4	30,600	F 33861	3 x 1/8 x 1/4	20,375	F 33876	4 x 1/8 x 1/2	15,280	F 33896
2 x 1/32 x 3/8	30,600	F 33863	3 x 1/8 x 3/8	20,375	F 33878	4-1/2 x 1/8 x 7/8	13,300	F 33895
2 x 1/16 x 1/4	30,560	F 33860	4 x 1/32 x 1/4	21,000	F 33882	4-1/2 x 3/32 x 7/8	13,300	F 33897
2 x 1/16 x 3/8	30,560	F 33862	4 x 1/32 x 3/8	21,000	F 33884	7 x 3/32 x D.M.	8,730	B 33900
2 x 1/8 x 1/4	30,560	F 33864	4 x 1/16 x 1/4	15,280	F 33886	8 x 3/32 x D.M.	7,640	B 33905
2 x 1/8 x 3/8	30,560	F 33866	4 x 1/16 x 3/8	15,280	F 33888	12 x 7/64 x 1	5,095	B 33910
3 x 1/32 x 1/4	24,200	F 33868	4 x 1/16 x 1/2	15,280	F 33890	14 x 7/64 x 1	4,365	A 33915
3 x 1/32 x 3/8	24,200	F 33870	-	-	-	-	-	-

E-Z KUT® FIBER DISCS

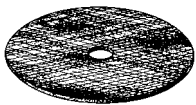

- PLIABLE DISCS THAT WORK EXCEPTIONALLY WELL FOR BOTH ROUGH AND FINE GRINDING ON FLAT AND IRREGULAR SURFACES
- ALUMINUM OXIDE - RESIN BOND CLOSED COAT
- HIGHLY ELASTIC RESINOID BONDING PREVENTS GRAIN PARTICLES FROM PREMATURE DISLODGING
- FOR USE ON ANGLE GRINDERS
- 7/8" CENTER HOLE
- USE FOR FINISHING OF WELDS, DEBURRING AND CLEANING OF FERROUS MATERIAL, FIBERGLASS, COPPER AND WOOD

SIZE	GRIT	PART	SIZE	GRIT	PART	SIZE	GRIT	PART	SIZE	GRIT	PART
5"	24	I 45700	5	50	I 45702	7"	36	E 45709	7"	60	E 45711

ABRASIVES

CUT-OFF WHEELS & GRINDING WHEELS

TYPE 27 - REINFORCED

Size: 4-1/2" x .045" x 7/8"
RPM: 13,300



- Zirconia and Aluminum Oxide mixture
- General purpose wheel
- Zirconia grain allows for faster cutting and longer life
- For steel and stainless steel applications

DESCRIPTION	PART
Type 27 Reinforced Cut-Off Wheels	E 33818

TYPE 27 - CONTAMINATE-FREE

Size: 4-1/2" x .045" x 7/8"
RPM: 13,300



- ≤ 0.1% iron, sulfur, or chlorine for rust-free and corrosion-free results
- High quality grain mixture is more friable and cuts freely
- White Aluminum Oxide grain
- For stainless steel, food grade and nuclear applications

DESCRIPTION	PART
Type 27 Contaminant Free Cut-Off Wheels	E 33819

TYPE 27 - GREEN GRINDING WHEEL / CONTAMINATE-FREE

P/N 33928
Size: 7" x 5/32" (4mm) x 7/8"
Grit: 36
RPM: 8,500

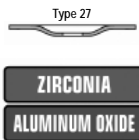

P/N 33929
Size: 4-1/2" x 5/32" (4mm) x 7/8"
Grit: 36
RPM: 13,300



- Exceptionally fast grinding
- Premium grain allows for high performance grinding action
- 50% faster metal removal than aluminum oxide wheels
- Contains less than 0.1% of sulfur & chlorine and virtually no iron
- Grain and bond engineered for cooler working
- Does not discolor or warp stainless steel
- Engineered for smoother, quieter working and less operator fatigue
- For grinding Stainless Steel • Mild Steel • Hard Face • Titanium • Inconel • Aluminum
- Great for tank fabrication • power plant maintenance • metal fabrication

DESCRIPTION	PART
Type 27 Green Grinding Wheel / Contaminate-Free, 7" Diameter	E 33928
Type 27 Green Grinding Wheel / Contaminate-Free, 4-1/2" Diameter	E 33929

27

ABRASIVES (Cont'd.)

CIC 200™ RAPID CUT MANDRELS

HUMMER WHEEL MANDRELS



- FLUSH MANDRELS TIGHTEN BY SCREW, CAN HANDLE ANY NUT-TYPE MANDREL APPLICATION.
- ALLOW EASY ACCESS TO AREAS INACCESSIBLE WITH NUT-TYPE MANDRELS (EX: FLUSH CUTS AND CORNER CUTS).

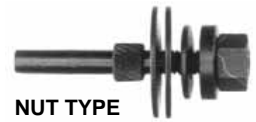

NUT TYPE

TYPE	SHANK SIZE	ARBOR HOLE SIZE	WHEEL THICKNESS	PART	
FLUSH SET	1/4" and 3/8"	1/4" and 3/8"	1/32" - 1/4"	C	33955
NUT	1/4"	1/4"	1/32" - 3/8"	B	33950
ADAPTER	1/4"	3/8"	1/32" - 1/4"	A	33801

MOUNTED POINTS

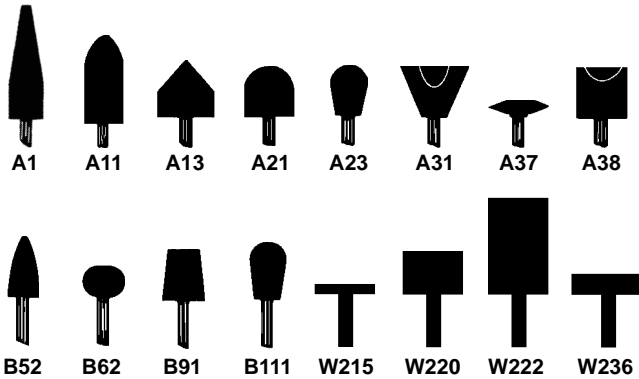

1/4" SHANKS

- FOR HIGH-SPEED AIR AND ELECTRIC GRINDERS.
- IDEAL FOR GRINDING DIES, CASTINGS, WELD SEAMS AND OTHER GENERAL METAL REMOVAL APPLICATIONS.
- MANUFACTURED WITH ALUMINUM OXIDE GRAIN AND VITRIFIED BOND.

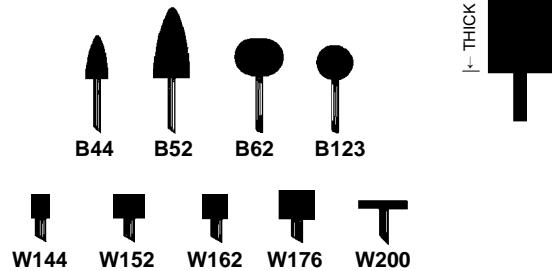

1/8" SHANKS

SHAPE NO.	DIA.	THICK	SHANK	MAX. R.P.M.	PART	
A1	3/4	2-1/2	1/4"	19,800	B	33840
A11	7/8	2	1/4"	19,860	B	33841
A13	1-1/8	1-1/8	1/4"	33,950	B	33842
A21	1	1	1/4"	34,500	B	33843
A23	3/4	1	1/4"	39,370	B	33844
A31	1-3/8	1	1/4"	27,780	B	33845
A37	1-1/4	1/4	1/4"	30,560	B	33846
A38	1	1	1/4"	34,500	B	33847
B52	3/8	3/4	1/4"	81,000	B	33848
B62	1/2	3/8	1/4"	71,250	B	33849
B91	1/2	5/8	1/4"	61,500	B	33850
B111	7/16	11/16	1/4"	66,000	B	33851
W215	1	1/8	1/4"	38,200	B	33852
W220	1	1	1/4"	25,500	B	33853
W222	1	2	1/4"	15,900	B	33854
W236	1-1/2	1/2	1/4"	25,470	B	33855
B44	7/32	3/8	1/8"	68,400	E	33825
B52	3/8	3/4	1/8"	45,370	E	33826
B62	1/2	3/8	1/8"	41,020	E	33827
B123	3/16	3/16	1/8"	104,250	E	33828
W144	1/8	1/4	1/8"	105,000	E	33829
W152	3/16	1/4	1/8"	105,000	E	33835
W162	1/4	3/8	1/8"	68,400	E	33836
W176	3/8	1/2	1/8"	45,370	E	33837
W200	3/4	1/8	1/8"	50,930	E	33838

IMPORTANT: All Wheels are manufactured under rigid quality conditions to insure product strength & safety. However, approved guards must be used for operator protection (ANSI Code B7.1).

ABRASIVES (Cont'd.)

PORTABLE SNAGGING WHEELS

OUTLASTS ALUMINUM OXIDE WHEELS 3 TO 1



TYPE II DESIGN

MANUFACTURED FROM A SPECIAL COMBINATION OF ABRASIVE ALLOYS THAT PROVIDE RUGGED, DURABLE, COOL FREE-CUTTING GRINDING PERFORMANCE.

PERFECT FOR:

- CLOSE GRINDING IN TIGHT CORNERS.
- QUICK METAL REMOVAL.
- NOTCH-FREE GRINDING AND SMOOTHING OF WELD SEAMS.
- PRE-WELD CLEANING.
- REMOVAL OF IMPERFECTIONS AND METAL PREPARATION PRIOR TO PAINTING.

SIZE	MAX. R.P.M.	PART	SIZE	MAX. R.P.M.	PART
4 ¹ / ₃ " x 2" x 5/8-11	9,070	A 33820	6 ¹ / ₄ -3 ¹ / ₄ " x 2" x 5/8-11	6,050	A 33824
5 ¹ / ₃ -3 ¹ / ₄ " x 2" x 5/8-11	7,260	A 33822	-	-	-

ALUMINUM OXIDE FLAP WHEELS

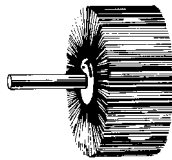

- ALUMINUM OXIDE COATED FLAPS.
- MANDREL MOUNTED ON FIXED 1/4" SOLID SHANK.
- FULL PACK GRIT, RESIN BONDED SEGMENTS.
- REMOVES WORK MARKS; SURFACE IMPERFECTIONS.
- POLISHES DIE WORK, SPOT WELDS, FIBERGLASS FORMS.
- DEBURRS STAINLESS STEEL; BLENDS AND POLISHES.
- REMOVES SCALE, RUST, PIT MARKS FROM STEEL.

WHEEL DIA.	WIDTH	GRIT	MAX. R.P.M.	PART	WHEEL DIA.	WIDTH	GRIT	MAX R.P.M.	PART
1	1	60	25,000	A 60713	2	1	60	23,000	A 60708
1	1	80	25,000	A 60715	2	1	80	23,000	A 60710
1-1/2	1	60	25,000	A 60714	2	1	120	23,000	A 60712
1-1/2	1	80	25,000	A 60716	3	1	60	20,000	A 60702
1-1/2	1	120	25,000	A 60718	3	1	80	20,000	A 60704
-	-	-	-	-	3	1	120	20,000	A 60706

BRAKE HUB CLEANING DISCS

Remove Rust and Corrosion Quickly

Brake hub cleaning disc and holder combine an aggressive 3-D disc construction with a unique, center hole attachment system for improved productivity. The system removes rust and corrosion quickly, even in hard to reach places. The attachment provides quick disc changes with the convenience of running on high-speed tools. All this adds up to saving time, increasing speed and effectiveness on the brake job.

Features

- Extremely tough 3-D web
- Non-metallic attachment system and disc pad holder
- Unique attachment system, Type H
- Disc holder is designed to fit on a variety of tools with collets or chucks
- Discs contain no wire filaments
- Potential for injury from flying wires is eliminated

Benefits

- Removes rust and corrosion without excessive metal removal or gouging of the metal
- Attachment button and holder are made of tough polymers that will not damage the wheel stud threads
- Disc locks securely; 1/2 turn on, 1/2 turn off (fits over wheel stud)
- Ideal for use on right angle air tools
- Helps to maintain AOEM surface milling marks
- Cleans the area fast while protecting the threads



- P/N 45616
Brake Hub Cleaning Disc (Pkg. 2)
- P/N 45615
Brake Hub Cleaning Disc Holder

ABRASIVES (Cont'd.)

ABRASIVE CLOTH SHOP ROLLS

- FAST CUTTING ALUMINUM OXIDE GRAIN THAT IS RESIN BONDED TO A FLEXIBLE "J" WEIGHT CLOTH BACKING
- USE FOR ALL FERROUS AND NON-FERROUS METALS, WOOD AND FIBERGLASS
- DESIGNED FOR EASY WORKABILITY AND LONG LIFE IN ALL MAINTENANCE, MACHINE SHOP OR PRODUCTION APPLICATIONS



ROLL SIZE (W x L)	GRIT		PART
1-1/2" x 150 Feet	60	A	60819
1-1/2" x 150 Feet	80	A	60820
1-1/2" x 150 Feet	100	A	60821
1-1/2" x 150 Feet	120	A	60822
1-1/2" x 150 Feet	180	A	60824
1-1/2" x 150 Feet	220	A	60825
1-1/2" x 150 Feet	240	A	60827
1-1/2" x 150 Feet	320	A	60826
1-1/2" x 150 Feet	400	A	60828

CLOTH SHEET ABRASIVE CLOTH

- ALUMINUM OXIDE SHEETS
- RESIN OVER RESIN CONSTRUCTION CLOTH BACKING FOR DURABILITY AND FLEXIBILITY
- STRONG BOND RESISTANT TO HEAT AND MOISTURE
- SUPERIOR PERFORMANCE ON FERROUS & NON-FERROUS MATERIALS, WOOD, PLASTIC AND FIBERGLASS
- WATER-RESISTANT



SIZE	GRIT		PART
9 x 11	36	I	60841
9 x 11	60	I	60844
9 x 11	80	I	60845
9 x 11	100	I	60846
9 x 11	120	I	60847
9 x 11	180	I	60849
9 x 11	240	I	60850
9 x 11	320	I	60852
9 x 11	400	I	60853
9 x 11	Assortment Pack (5 Sheets Each) 36, 80, 120, 240 and 320		A 60855

ALUMINUM OXIDE AND SILICONE CARBIDE HAND PADS

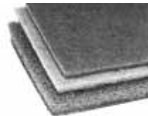

- FLEXIBLE NON-WOVEN NYLON IMPREGNATED WITH ABRASIVE GRAIN.
- OPEN STRUCTURE PREVENTS LOADING.
- CAN BE USED WET OR DRY.
- DESIGNED FOR GENERAL CLEANUP, LIGHT DEBURRING, BLENDING AND SATIN FINISHING ON ALL TYPES OF FERROUS AND NON-FERROUS METALS.

SIZE	TYPE	COLOR		PART
6" x 9"	General Purpose A/O	Maroon	I	60838
6" x 9"	Ultra-Fine S/C	Gray	I	60840
6" x 9"	Coarse A/O	Brown	E	45750

SILICONE CARBIDE SCREEN-BAK ABRASIVE ROLLS

- OPEN SCREEN FOR HIGH SPEED SANDING.
- USE WET OR DRY.
- OUTPERFORMS ALL OTHER HAND SANDING ABRASIVES.
- NON-CLOGGING, NO LOADING, USE BOTH SIDES FOR METAL, WOOD, PLASTIC, GLASS AND CERAMIC APPLICATIONS.
- LEAVES SURFACES FREE OF LINES, SCRATCHES AND MARKS.

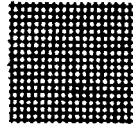

- IDEAL FOR:**
- BODY REPAIRS.
 - CLEANING BRASS, COPPER, COPPER TUBING AND ENDS.
 - REMOVING GLAZE FROM NEW PARTS.
 - SMOOTHING ROUGH SPOTS, DEBURRING AND CLEANING MOST SURFACES.

ROLL SIZE (W x L)	GRIT		PART
1-1/2" x 30'	80	A	60830
1-1/2" x 30'	120	A	60832
1-1/2" x 30'	180	A	60834
1-1/2" x 75'	120	A	60835
Assort. (3 rolls 1-1/2" x 30')	1 ea. 80, 120, 180	A	17711

ABRASIVES (Cont'd.)

TRIM KUT™ SANDING DISCS

- TOUGH ALUMINUM OXIDE GRAIN – IMPREGNATED INTO DURABLE PLASTIC (POLYAMIDE) BACKING
- EXTREMELY LIGHTWEIGHT – FOR EASY USE WITH POWER HAND TOOLS
- EASILY TRIMMED – EXPOSING NEW CUTTING SURFACE AND MAXIMIZING ABRASIVE
- CAN BE USED ALL THE WAY TO THE CORE – FOR ULTIMATE CONSUMPTION AND VALUE
- NO TOOLING – SIMPLY SPIN-ON AND SPIN-OFF

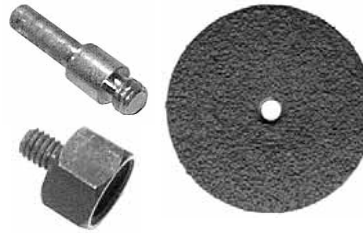

- APPLICATIONS:**
- CLEANING IMPERFECTIONS
 - BLENDING WELDS
 - EDGE GRINDING

SIZE / DIAMETER	GRIT	PART	SIZE / DIAMETER	GRIT	PART
3	36	E 33960	5	36	E 33963
3	60	E 33961	5	60	E 33964
3	120	E 33962	5	120	E 33965
Trim-Kut Mandrel with 1/4" Shank		B 33966	Trim-Kut Mandrel with 5/8-11 Thread Anchor		B 33967

SURFACE PREP WHEELS

- SURFACE PREPARATION FOR STEEL, ALUMINUM, STAINLESS AND NON-FERROUS METALS
- LIGHT DEBURRING
- REMOVING DISCOLORATION CAUSED BY WELDING OR CUTTING
- PAINT AND RUST REMOVAL
- ALUMINUM OXIDE FOR FINE FINISH WORK
- SILICON CARBIDE FOR SUPER FINE FINISH WORK



MAXIMUM RPM – 8500

SIZE	GRADE	GRAIN	COLOR	PART	SIZE	GRADE	GRAIN	COLOR	PART
7 x 7/8	Fine	Alum. Oxide	Maroon	E 33920	7 x 7/8	Super Fine	Silicon Carb.	Grey	E 33922
7 x 5/8-11	Fine	Alum. Oxide	Maroon	E 33921	7 x 5/8-11	Super Fine	Silicon Carb.	Grey	E 33923

POW-R-CUT™ FLAP DISCS / TYPE 29

This multi-layered, resin bonded, zirconium aluminum abrasive disc is excellent for grinding of welded seams, deburring, beveling, rust removal and surface blending. With multi-layer construction, new abrasive is constantly being exposed, giving the surface a consistent and uniform finish. Ideal for use on stainless steel, cast iron, high strength aluminum, bronze and copper as well as low alloy steel.

- High removal rate for increased productivity
- Soft, cool cutting prevents burning and allows contouring
- Unique fiberglass hub wears simultaneously with abrasive And will not damage the work surface
- Longer life assures lowered costs
- Low noise and no vibrations provide Smoother finish with less fatigue
- Requires less pressure for improved results & longer use

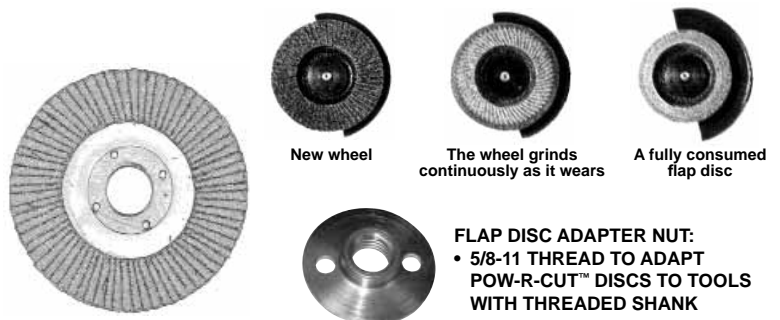

FLAP DISC ADAPTER NUT:

- 5/8-11 THREAD TO ADAPT POW-R-CUT™ DISCS TO TOOLS WITH THREADED SHANK

SIZE	GRIT	MAXIMUM RPM	PART
4-1/2 x 7/8	40	13,000	C 33930
4-1/2 x 7/8	80	13,000	C 33932
4-1/2 x 7/8	120	13,000	C 33931
7 x 7/8	40	8,500	C 33933
7 x 7/8	80	8,500	C 33935
FLAP DISC ADAPTER NUT			D 33940

ABRASIVES – FLAP DISCS, TYPE 27 & 29, Z3



Z3 FLAP DISCS – 4-1/2" X 7/8"

DESCRIPTION AND APPLICATIONS

- Premium Zirconia Alumina grain with a poly/cotton heat treated backing. The poly/cotton combination provides low stretch and strength for the high Zirconia concentration that Z3 contains.
- Special optimized resin bond offers maximum cutting capacity, strong edge stability and long life.
- Fastest grain removal in the marketplace for carbon based steels (26% more than the competition) and second best after Stainless discs on stainless steels, while offering excellent life.
- For aggressive use and heavy duty applications.
- Active grinding agent provides cool cutting with light pressure.
- High Density (XL) flap discs have approximately 35% to 55% more material than Regular Density Z3 flap discs. High Density flap discs require high output angle grinders for best results.

Regular Density

Fast removal rate for aggressive use and heavy duty applications.



High Density (XL)

Approximately 35-55% more material than regular Z3 flap discs.



40 Grit discs shown.



Flap Disc Adapter Nut P/N 33940

With 5/8-11 thread to adapt Z3 USA Made Flap Discs to tools with threaded shank.



Abrasive Wheel Dispenser P/N 50032

- For 4-1/2" diameter flap discs, cut-off wheels, etc.
- Heavy-duty construction with flip top for loading discs
- Wide-mouth bottom for easy-access dispensing
- Gravity feed
- Can hold up to 25 flap discs
- 4 holes for wall mounting
- Dimensions:
16-1/8" H x 6-1/4" W x 5-1/4" D

27

ZIRCONIA



ABRASIVES – FLAP DISCS, TYPE 27 & 29, Z3

TYPE 27 – REGULAR DENSITY

40, 60, 80, 120 GRIT



T-27
For working on flat grinding surfaces. Best choice for smooth finishing.

Regular Density
Fast removal rate for aggressive use and heavy duty applications.

TYPE 29 – REGULAR DENSITY

40, 60, 80, 120 GRIT



T-29
For working on contoured and edge work. Flaps are angled at 8 degrees for greater surface contact and aggressive use.

Regular Density
Fast removal rate for aggressive use and heavy duty applications.

SIZE	GRIT	PART NO.	RPM
4-1/2" x 7/8"	40	A 33970	13,300
4-1/2" x 7/8"	60	A 33971	13,300
4-1/2" x 7/8"	80	A 33972	13,300
4-1/2" x 7/8"	120	A 33973	13,300

SIZE	GRIT	PART NO.	RPM
4-1/2" x 7/8"	40	A 33980	13,300
4-1/2" x 7/8"	60	A 33981	13,300
4-1/2" x 7/8"	80	A 33982	13,300
4-1/2" x 7/8"	120	A 33983	13,300



T-27 / Flat - For working on flat grinding surfaces. Most efficient when used between 0°-15° angle. The best choice for smooth finishing.



T-29 / Conical - For working on contoured and edge work. Flaps are angled at 8 degrees for greater surface contact and aggressive use. Best used at 15°-25° angle.

TYPE 27 – HIGH DENSITY (XL)

40, 60, 80, 120 GRIT



T-27
For working on flat grinding surfaces. Best choice for smooth finishing.

High Density
Approximately 35-55% more material than regular Z3 flap discs.

TYPE 29 – HIGH DENSITY (XL)

40, 60, 80, 120 GRIT



T-29
For working on contoured and edge work. Flaps are angled at 8 degrees for greater surface contact and aggressive use.

High Density
Approximately 35-55% more material than regular Z3 flap discs.

SIZE	GRIT	PART NO.	RPM
4-1/2" x 7/8"	40	A 33975	13,300
4-1/2" x 7/8"	60	A 33976	13,300
4-1/2" x 7/8"	80	A 33977	13,300
4-1/2" x 7/8"	120	A 33978	13,300

SIZE	GRIT	PART NO.	RPM
4-1/2" x 7/8"	40	A 33985	13,300
4-1/2" x 7/8"	60	A 33986	13,300
4-1/2" x 7/8"	80	A 33987	13,300
4-1/2" x 7/8"	120	A 33988	13,300

BRUSHES

DISPOSABLE PAINT/CHIP BRUSHES

- NATURAL WOOD HANDLE
- 100% PURE WHITE BRISTLES
- BRISTLES SET IN EPOXY FOR SOLVENT RESISTANCE

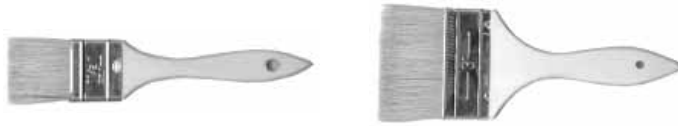

SIZE	PART	SIZE	PART	SIZE	PART
1"	J 21576	2"	J 21578	3"	F 21580
1-1/2"	J 21577	2-1/2"	F 21579	4"	21581

3-1/2" TAMPICO BRUSH

THIS BRUSH IS SET IN A WOOD BLOCK, GENEROUSLY FILLED WITH WHITE TAMPICO.

A USEFUL AND INEXPENSIVE TOOL FOR APPLYING A VARIETY OF MATERIALS SUCH AS:

- THICK CHEMICALS
- MASONRY CEMENT
- LIQUID WATERPROOFING ON ROUGH SURFACES
- BLOCK SIZE - 6-3/8" X 1-11/16"



P/N 21575

WIRE WHEELS BRUSHES

- HEAVILY FILLED WITH HIGH QUALITY, OIL TEMPERED CRIMPED WIRE PROVIDING A CONTINUOUS BRUSHING ACTION FOR A FINE FINISH
- FIXED ARBOR DESIGN ALLOWS FOR INDIVIDUAL OR MULTIPLE BRUSH ASSEMBLIES

INCREASE OPERATOR SAFETY AND EXTEND BRUSH LIFE BY:

1. INSPECTING BRUSH FOR DAMAGE, RUST OR FOREIGN MATERIAL BEFORE MOUNTING.
2. USING ONLY MACHINES THAT HAVE ENOUGH POWER TO MAINTAIN RATED SPINDLE SPEEDS YET NOT EXCEED THE MAXIMUM SAFE FREE SPEED OF THE BRUSH.
(NOTE: RECOMMENDED MOTOR SIZE FOR A 6" WHEEL IS 1/2 H.P. 3,450 RPM)
3. MAKING SURE ALL MACHINE GUARDS ARE IN PLACE BEFORE USING AND ALWAYS WEARING EYE PROTECTION.
4. PREVENTING WIRES FROM BECOMING OVER-STRESSED BY APPLYING ONLY ENOUGH PRESSURE FOR THE WIRE TIPS TO COME IN CONTACT WITH THE WORK. (LETTING THE WIRE TIPS DO ALL THE WORK).
5. PREVENTING WIRE TIPS FROM BECOMING DULL, BY REVERSING BRUSH ROTATION PERIODICALLY.

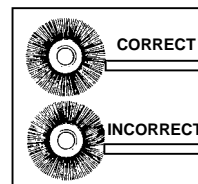

DIAMETER	WIRE SIZE	FACE WIDTH	TRIM LENGTH	ARBOR ARBOR HOLE	MAX. SAFE FREE R.P.M.	PART NUMBER
6	.014	3/4	1-1/8	5/8-1/2	6,000	A 41300
6	.020	3/4	1-1/8	5/8-1/2	6,000	A 41305
8	.014	3/4	1-1/2	5/8-1/2	4,500	A 41308

RECOMMENDED SURFACE SPEEDS FOR TYPICAL BRUSHING APPLICATIONS

APPLICATION	SURFACE FT./MIN.	R.P.M.	APPLICATION	SURFACE FT./MIN.	R.P.M.
Removing Butts	5,500 to 7,500	3,750 - 4,500	Cleaning (Dry)	4,000 to 5,500	2,500 - 3,450
Removing Scale	7,500 to 10,000	5,000 - 6,000	Cleaning (Wet)	1,900 to 4,000	1,500 - 2,500
Cleaning Welds	7,200 to 9,400	5,000 - 6,000	Surface Polishing	6,400 to 8,000	4,500 - 5,000
Edge Bending	4,700 to 7,500	3,000 - 4,500	Surfacing Buffing	8,000 to 10,000	6,000

BRUSHES (Cont'd.)

WIRE END BRUSHES

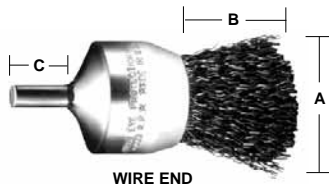

WIRE END



CIRCULAR FLARED END



HOLLOW END

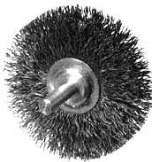

STEM MOUNTED



KNOTTED CUP

HIGH QUALITY, OIL TEMPERED, CRIMPED WIRE PROVIDES SUPERIOR CUTTING CHARACTERISTICS AND FATIGUE RESISTANCE WHILE A STANDARD 1/4" STEM MAKES THEM PERFECT FOR USE IN PORTABLE AIR, ELECTRIC AND DRILL PRESS CHUCKS

TYPICAL APPLICATIONS:

- WELD CLEANING
- MOLD CLEANING
- DEBURRING
- POLISHING TOOLS, DIES AND MOLDS
- REMOVING RUST AND PAINT
- SPOT PAINTING

DESCRIPTION	(A) DIA.	(B) TRIM LENGTH	(C) STEM	WIRE SIZE	PART	MAX. SAFE FREE SPEED RPM
Wire End	1/2	7/8	1/4	.014	B 41320	20,000
Wire End	3/4	7/8	1/4	.014	B 41315	20,000
Circular Flared End	1-1/2	—	1/4 x 7/8	.006	A 41325	20,000
Circular Flared End	3	—	1/4 x 7/8	.008	A 41326	15,000
Hollow End	1-3/4	3/4	1/4	.0118	A 41330	13,000
Stem Mounted	2	—	1/4	.0118	A 41335	20,000
Stem Mounted	3	—	1/4	.014	A 41336	20,000
Knotted Cup	4	1-1/4	5/8-11	.014	A 41350	8,500
Knotted Cup	6	1-3/8	5/8-11	.014	A 41352	6,000

HAND SCRATCH BRUSHES

PIPE/TUBE BRUSH FEATURES:

- CLEANS BOTH THE INSIDE AND OUTSIDE OF COPPER TUBING IN PREPARATION FOR SOLDER WHEN SWEATING PIPES
- CLEANS MOST POPULAR 1/2" AND 3/4" I.D. TUBE AND 5/8" & 7/8" O.D. TUBE
- HARDENED STEEL BRUSHES AND POLYPROPYLENE BODY FOR STRENGTH AND DURABILITY

HAND SCRATCH BRUSHES FEATURES:

- CONSTRUCTED OF HEAVY GAUGE WIRE EMBEDDED IN A HEAVY DUTY HARDWOOD HANDLE
- USE FOR REMOVING PAINT, RUST, SCALE, SOLDER CHIPS AND DIRT
- CLEANS METAL PARTS, THREADS, FILES, ETC.



4-IN-1 PIPE/TUBE BRUSH



GENERAL PURPOSE



3/8 OR 1/2 ACID SWAB BRUSH



1/2 OR 3/4 TUBE FITTING BRUSH



S/S SHOE HANDLE



NYLON, BRASS OR STAINLESS STEEL SMALL SCRATCH PLASTIC HANDLE

DESCRIPTION	ROWS	OVERALL LENGTH	TRIM	BRUSH LENGTH	PART
General Purpose	4 x 19	13-1/4	1-1/8	6	B 41310
S/S Shoe Handle	4 x 16	10	1-1/8	5-1/2	A 41312
S/S Small Scratch	3 x 7	7-7/8	1/2	1-3/8	C 41340
Brass Small Scratch	3 x 7	7-7/8	1/2	1-3/8	C 41342
Nylon Small Scratch	3 x 7	7-7/8	1/2	1-3/8	B 41347
3/8 Acid Swab	—	5-3/4	3/4	3/8 (width)	J 41345
1/2 Acid Swab	—	5-3/4	3/4	1/2 (width)	J 41346
1/2 S/S Tube Fitting	—	6-1/2	—	1/2 (width)	B 41348
3/4 S/S Tube Fitting	—	6-1/2	—	3/4 (width)	B 41349
4-in-1 Pipe/Tube Brush	—	7-1/2	—	3/4 (width) and 1" (width)	A 41344

SCRAPERS

RAZOR BLADE SCRAPER

SCRAPER FEATURES:

- Retractable blade
- Strong, galvanized, non-rusting steel
- Comfortable, form-fitted grip



BLADE FEATURES:

- High quality, carbon steel double-beveled ground razor edge
- Folded steel backing (crimped/both ends) holds blade securely
- Individually wrapped in cardboard sleeves

DESCRIPTION	PART
Industrial Scraper	E 66403
#9 Industrial Blades	T 66402

HAND SCRAPERS

- STAINLESS STEEL SCRAPERS HAVE A THREADED HANDLE TO FIT ANY WOOD OR ALUMINUM POLE – EASY ACCESS FOR HARD TO REACH AREAS



- ROLLERGRIP HANDLE ENSURES YEARS OF DEPENDABLE SERVICE AND A FIRM AND COMFORTABLE GRIP

DESCRIPTION	PART
3-1/8" Flat Stainless Steel	A 66405
3" 20° Stainless Steel	A 66406

SUPER SCRAPERS

- Unique head design for easy blades changes and proper angle for scraping
- Durable and dependable
- The 4" ergonomically designed scraper will get into the tightest places
- Use the 8" and 13" scraper for those tough to reach areas



DESCRIPTION	PART
4" Mini Scraper	A 66407
8" Super Scraper	A 66408
13" Super Scraper	A 66409

UTILITY KNIVES

AUTO-LOAD UTILITY KNIFE

- SLIDER KNOB AUTOMATICALLY LOADS NEW BLADE
- SIDE LOADING 5 BLADE CHAMBER
- NO PARTS TO LOSE
- ERGONOMIC HANDLE WITH RUBBER GRIP
- PUSH BUTTON BLADE REMOVAL



DESCRIPTION	PART
"AUTO-LOAD" UTILITY KNIFE WITH 5 BLADES	A 66412

ERGO-KNIFE™

- HINGED HANDLE MAKES IT EASY TO CHANGE BLADES
- ERGONOMICALLY DESIGNED TO PROVIDE MAXIMUM POWER WITH MINIMUM FATIGUE
- INTERNAL BLADE CADDY HOLDS BLADES SAFELY AND CONVENIENTLY
- PATENTED QUICK RELEASE HANDLE ELIMINATES THE NEED FOR A SCREWDRIVER OR TOOLS TO CHANGE BLADES
- RETRACTABLE BLADE FOR EASY USE AND SAFE STORAGE



DESCRIPTION	PART
"ERGO-KNIFE" UTILITY KNIFE WITH 6 BLADES (1 COMBO, 5 STRAIGHT)	A 66410

BLADES

METAL BLADES



PLASTIC BLADES



- PATENT PROTECTED
- BLUE FOR INSTANT RECOGNITION
- UNBREAKABLE – SPRING BACKING STEEL FLEXES BUT WILL NOT BREAK
- STAYS SHARPER 3X LONGER – HIGH SPEED STEEL EDGE HEAT TREATED TO HIGHER HARDNESS THAN STANDARD CARBON

DESIGNED WITH 2 SHARP EDGES FOR SCRAPING, CLEANING AND PEELING, NOT FOR CUTTING. WON'T DAMAGE SURFACE MATERIAL. BREAKS BOND BETWEEN SURFACE AND SUBSTANCE TO BE REMOVED.

DESCRIPTION	PART
Hook Blade	N 66418
Round Blade	N 66421
Economy Straight Blade*	T 66414
Bi-metal Utility Knife Blade*	A 66415
Bi-metal Utility Knife Blade Dispenser Pack*	T 66415-100
General Purpose Double-sided Plastic Blade	N 66423
Irwin "Safety Knife" Blades (Pkg. 5)	E 66506
Irwin "Safety Knife" Blades (Pkg. 50)	R 66506-50
Irwin "Safety Knife" Blades (Pkg. 100)	T 66506-100
Serrated Shark Knife Blades (Pkg. 5)	E 66508
Serrated Shark Knife Blades (Pkg. 50)	R 66508-50
Serrated Shark Knife Blades (Pkg. 100)	T 66508-100

*0.025 thick

UTILITY KNIVES (Cont'd.)

SUPERKNIFE™



- 17912B
- 17912S

- ANODIZED ALUMINUM HANDLE & STAINLESS STEEL
- ERGONOMIC STYLE / WITH BELT CLIP
- ONE STEP BLADE CHANGE – NO TOOLS REQUIRED
- DURABLE AND LIGHTWEIGHT
- FOLDING BLADE HOLDER ACCEPTS MOST STANDARD UTILITY BLADES INCLUDING CONTRACTOR GRADE

- THE ULTIMATE UTILITY KNIFE CARRYING CASE
- HOLDS REPLACEMENT BLADES
- VERSATILE STAINLESS STEEL BELT CLIP
- ACCOMMODATES 2" BELTS
- DURABLE BALLISTIC NYLON

DESCRIPTION	PART	
SUPERKNIFE – SILVER	A	66500S
SUPERKNIFE – BLACK	A	66500B
SUPERKNIFE CASE	A	66500CASE

MINI SUPERKNIFE™

- THE ULTIMATE UTILITY KNIFE HOLDS STANDARD MINI UTILITY BLADES
- RELEASE BUTTON LOCKS OPEN, LOCKS CLOSED
- FOLDS DOWN TO 1-3/4"
- KEYCHAIN LANYARD
- INCLUDES 3 SPARE BLADES
- AVAILABLE IN BLACK AND SILVER



INCLUDES 3 SPARE BLADES

INSTRUCTIONS FOR REPLACING BLADES:

1. Remove the phillips screw holding the blade in the knife.
2. Once the screw is removed, holding the knife away from your body, slowly remove the old blade.
3. Replace the new sharp blade and reinstall the phillips screw.
4. Tighten firmly to remove any movement in the blade.

DESCRIPTION	PART	
MINI SUPERKNIFE – SILVER	A	66501S
MINI SUPERKNIFE – BLACK	A	66501B
MINI STRAIGHT BLADE	N	66417

SAFETY CUTTER

Take it anywhere in the workplace for most small cutting jobs. Safely put it in a pocket when finished. The spring-back blade keeps you safely away from the blade while cutting and when you are not.



- Designed for right or left-handed use
- Ultra Sharp – Cut Boxes, Tape, String, Paper or Plastic
- Folds Up To Safely Conceal Blade When Not In Use
- Blunt Safety Tip Blade Prevents Puncture Wounds
- Convenient Size Fits In Pocket Or Attached To A Lanyard

DESCRIPTION	PART	
Safety Cutter	A	66503
Replacement Blades	A	66504

IRWIN SELF RETRACTING "SAFETY KNIFE"

- Self-retracting spring action returns blade safely into the housing when not in use
- Bi-metal safety blade with blunted ends inhibits puncture wounds
- Two blade positions:
 - 2 mm extension for box cutting
 - Full extension for general use
- Interlocking nose reduces blade wobble
- Ergonomic grip fits comfortably in the hand

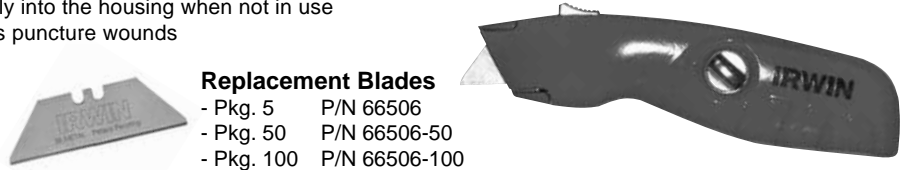

Replacement Blades

- Pkg. 5 P/N 66506
- Pkg. 50 P/N 66506-50
- Pkg. 100 P/N 66506-100

DESCRIPTION	PART	
IRWIN Self Retracting Safety Knife (includes one IRWIN bi-metal safety blade)	A	66505

SHARK UTILITY KNIFE - WIRE STRIPPER & UTILITY KNIFE

- Precision-ground stripping holes for easy removal of wire insulation. For wire sizes: 10, 12, 14, 16, 18 AWG
- Longer lasting, faster cutting multi-purpose serrated blades
- Quick change blade feature
- Extra blade storage compartment
 - Loaded with 4 serrated blades



Serrated Replacement Blades

- Pkg. 5 P/N 66508
- Pkg. 50 P/N 66508-50
- Pkg. 100 P/N 66508-100

DESCRIPTION	PART	
SHARK UTILITY KNIFE (with total of 5 serrated blades)	A	66507

STEEL WIRE SPRINGS (Cont'd.)

COMPRESSION SPRINGS



WIRE DIA.	O.D.	OVERALL LTH.	ENDS	INDUST. PART	PART	WIRE DIA.	O.D.	OVERALL LTH.	ENDS	INDUST. PART	PART
.054	1/2	1-3/4	Z	13	M 60213	.022	1/4	1-7/8	Z	72X	M 60272
.091	5/8	1-3/4	Z	14	M 60214	.025	5/16	1-7/16	Z	74X	M 60274
.072	5/8	2	Z	16	M 60216	.041	5/16	2	Z	76X	M 60276
.041	5/16	1-3/8	Z	17	M 60217	.035	3/8	1-7/16	Z	77X	M 60277
.020	5/16	1-1/2	Z	18	M 60218	.041	3/8	1-15/16	Z	79X	M 60279
.030	13/64	2-1/4	Z	19	M 60219	.062	1/2	1-7/16	Z	80X	M 60280
.015	7/32	1-5/8	Z	20	M 60220	.047	1/2	1-3/4	Z	82X	M 60282
.022	3/16	1-5/16	Z	21	M 60221	.041	7/16	1-7/16	Z	84X	M 60284
.032	7/32	1-1/4	Z	22	M 60222	.054	5/8	1-9/16	Z	85X	M 60285
.026	5/16	1-7/8	Z	23	M 60223	.032	15/64	1-3/4	Z	87X	M 60287
.041	5/16	2-5/16	Z	24	M 60224	.062	5/8	2	Z	89X	M 60289
.023	1/4	2	Z	25	M 60225	.035	5/16	1-1/2	Z	90X	M 60290
.047	7/16	3	Z	26	M 60226	.032	5/16	1-11/16	Z	92X	M 60292
.062	7/16	3-1/4	Z	32	M 60232	.025	1/4	2	Z	94X	M 60294
.047	21/64	3-5/16	Z	33	M 60233	.047	5/16	1-1/2	Z	95X	M 60295
.080	15/32	2-3/8	Z	35	M 60235	.047	3/8	1-1/2	Z	96X	M 60296
.047	15/32	1-1/8	Z	37	M 60237	.032	1/4	1-7/16	Z	98X	M 60298
.080	11/16	1-1/2	Z	39	M 60239	.025	3/8	1-7/8	Z	99X	M 60299
.062	1/2	2-13/16	Z	41	M 60241	.047	7/16	1-3/4	Z	412	M 60412
.062	11/16	3	Z	43	M 60243	.091	5/8	1-3/4	Z	413	M 60413
.047	3/4	3-3/8	Z	45	M 60245	.072	9/16	1-3/4	Z	415	M 60415
.080	7/8	3-7/16	Z	47	M 60247	.041	5/16	1-3/8	Z	416	M 60416
.080	7/16	5	Y	48	M 60248	.020	5/16	1-1/2	Z	417	M 60417
.105	31/32	3-3/4	Z	49	M 60249	.030	13/64	2-1/4	Z	418	M 60418
.041	15/32	5-1/4	Z	54	M 60254	.015	7/32	1-5/8	Z	419	M 60419
.062	13/16	3-1/4	Z	55	M 60255	.023	3/16	1-5/16	Z	420	M 60420
.120	1-1/32	5-3/8	Z	56	J 60256	.020	3/16	1-1/8	Z	421	M 60421
.105	3/4	3	Z	57	M 60257	.026	5/16	1-7/8	Z	422	M 60422
.120	1-1/4	4-5/8	Z	58	J 60258	.041	5/16	2-5/16	Z	423	M 60423
.135	1	3-3/4	Z	59	J 60259	.023	1/4	2	Z	424	M 60424
.072	11/16	9-1/2	Z	60	J 60260	.047	7/16	3	Z	425	M 60425
.120	15/16	9-7/8	Z	61	J 60261	.028	21/64	1-1/8	Z	427	M 60427
.041	5/8	2-11/16	Z	65	M 60265	.047	5/16	1-1/2	Z	428	M 60428
.028	21/64	1-1/8	Z	67X	M 60267	.020	1/4	2	Z	429	M 60429
.020	1/4	2	Z	69X	M 60269	.025	5/16	1-7/16	Z	430	M 60430
.020	3/16	1-1/2	Z	71X	M 60271	.032	1/4	1-7/16	Z	431	M 60431

CONE COMPRESSION SPRINGS



WIRE DIA.	MIN. O.D.	MAX. O.D.	OVERALL LTH.	ENDS	INDUST. PART	PART
.041	13/32	11/16	1	Z	7	M 60207*
.041	13/32	11/16	1	Z	407	M 60407**

DOUBLE CONE COMPRESSION SPRINGS



WIRE DIA.	MIN. O.D.	MAX. O.D.	OVERALL LTH.	ENDS	INDUST. PART	PART
.047	7/16	11/16	2	Z	12	M 60212
.054	5/16	9/16	2	Z	411	M 60411

*YELLOW PLATE **ZINC PLATE

STEEL WIRE SPRINGS (Cont'd.)

TORSION SPRINGS

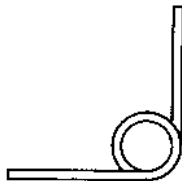

WIRE DIAMETER	OUTSIDE DIAMETER	LEG LENGTH	COILS	INDUSTRY PART	PART
.072	1/2	2-1/4	1	15	M 60215
.072	1/2	2-1/4	2	414	M 60414

SPRING ASSORTMENTS

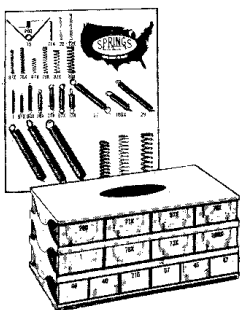

250 PIECE ASSORTMENT

DESCRIPTION	PART
<ul style="list-style-type: none"> • Plastic cabinet with 15 plastic drawers • 250 springs (27 different types) • Colorful counter display card which can also be hung on the wall. • Dimensions: 10" Wide x 6" Deep x 9" High 	A 60460

400 PIECE ASSORTMENT

DESCRIPTION	PART
<ul style="list-style-type: none"> • Metal wall display with 50 mounted springs. • 2-drawer metal cabinet with 52 compartments. • 400 springs; 50 different numbers. • Each compartment is clearly numbered to correspond with the actual numbered items mounted on the metal display. • Includes P/N 60401 to 60450 • Dimensions: 8" High x 20" Wide x 12" Deep 	A 60400



1000 PIECE ASSORTMENT

DESCRIPTION	PART
<ul style="list-style-type: none"> • Metal display with spring assortment. • Matching metal 4-drawer cabinet. • Includes P/N 60201 to 60300 • Dimensions: 18" High x 20" Wide x 12" Deep • Each compartment is clearly numbered to correspond with the actual numbered items mounted on the metal display. 	A 60200



MECHANIC'S WIRE

GALVANIZED STEEL WIRE







- FLEXIBLE STEEL WIRE
- GALVANIZED FOR DURABILITY
- HANGS CONDUIT, PIPE, ETC.
- MAKES TEMPORARY/EMERGENCY REPAIRS



WIRE GAUGE	SIZE	PART	WIRE GAUGE	SIZE	PART
14 ga.	5 Lb. Spool	A 60390	18 ga.	5 Lb. Spool	A 60392
16 ga.	5 Lb. Spool	A 60391	-	-	-

"S" HOOKS



ZINC PLATED STEEL



 		HEAVY OPEN STYLE				
		WIRE SIZE	DECIMAL EQUIVALENT	OVERALL LENGTH	INSIDE DIA. OF "S"	PART
14	.080	1	5/16	T	1900	
7	.177	1-1/2	7/16	R	1901	
6	.192	1-3/4	17/32	R	1902	
2	.262	2	9/16	R	1903	
0	.306	2-1/2	25/32	N	1904	
0	.306	3	15/16	N	1905	



 		LIGHT OPEN STYLE				
		WIRE SIZE	DECIMAL EQUIVALENT	OVERALL LENGTH	INSIDE DIA. OF "S"	PART
9	.148	1-1/2	5/8	R	1960	
8	.162	1-7/8	3/4	R	1961	
6	.192	2-1/8	7/8	R	1962	
5	.207	2-7/16	1	N	1963	
2	.262	2-3/4	1-1/8	N	1964	

 		LIGHT CLOSED STYLE				
		WIRE SIZE	DECIMAL EQUIVALENT	OVERALL LENGTH	INSIDE DIA. OF "S"	PART
12	.105	1-1/8	5/16	T	1993	
11	.120	1-1/4	3/8	T	1992	
10	.135	1-5/8	1/2	T	1991	
9	.148	2-1/8	3/4	T	1990	

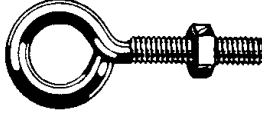
EYEBOLTS

REGULAR TURNED EYE					
<ul style="list-style-type: none"> • ZINC PLATED STEEL EYEBOLTS • NUT ASSEMBLED TO BOLT • ROLLED THREADS • U.S. STANDARD  					
SIZE	THREAD LENGTH	SHANK LENGTH	INSIDE DIA. EYE	PART	
3/16 x 2-1/2	1-1/4	1-5/8	1/2	N	60881
3/16 x 3	2	2-1/4	1/2	N	60882
1/4 x 2	3/4	1	9/16	N	60883
1/4 x 3	1-3/4	2	9/16	N	60884
1/4 x 4	2-3/4	3	9/16	N	60885
1/4 x 5	3-3/8	4	9/16	N	60886
1/4 x 6	4	5	9/16	N	60887
1/4 x 8	4	7	9/16	N	60888
5/16 x 3-1/4	1-3/4	2	3/4	N	60889
5/16 x 4	2-1/2	2-3/4	3/4	N	60890
5/16 x 5	3-1/4	3-3/4	3/4	N	60891
5/16 x 6	4	4-3/4	3/4	N	60892
5/16 x 8	4	6-3/4	3/4	L	60893
3/8 x 4	2	2-1/4	1	N	60894
3/8 x 5	3	3-1/4	1	L	60895
3/8 x 6	4	4-1/4	1	L	60896
3/8 x 8	4	6-1/4	1	L	60897
1/2 x 6	3-1/4	3-3/4	1-1/4	I	60900
1/2 x 8	4	5-3/4	1-1/4	E	60901
1/2 x 10	4	8	1-1/4	E	60902
1/2 x 12	4	9-1/8	1-1/4	E	60903

SMALL TURNED EYE					
<ul style="list-style-type: none"> • ZINC PLATED STEEL  					
SIZE	THREAD LENGTH	SHANK LENGTH	INSIDE DIA. EYE	PART	
5/32 x 1-5/8	1	1-1/8	1/4	R	60808
3/16 x 2	1-1/4	1-5/16	5/16	R	60809
7/32 x 2-3/16	1-1/2	1-3/8	3/8	R	60810
1/4 x 2-5/8	1-3/8	1-9/16	1/2	R	60811
5/16 x 3-1/4	1-1/2	2-1/4	1/2	N	60812
3/8 x 3-3/4	2-1/4	2-1/2	5/8	N	60813



LAG SCREW					
<ul style="list-style-type: none"> • ZINC PLATED STEEL  					
SIZE	THREAD LENGTH	SHANK LENGTH	WIRE SIZE	INSIDE DIA. EYE	PART
1/4 x 3-3/4	1-1/2	2-3/4	3	1/2	N 1166
1/4 x 5	1-1/2	4	3	1/2	N 1167
5/16 x 4	1-5/8	2-3/4	0	5/8	I 1168
5/16 x 6	1-5/8	4-3/4	0	5/8	I 1169
3/8 x 4-1/2	2	3-1/16	000	3/4	I 1170
3/8 x 8	2	5-9/16	000	3/4	I 1171

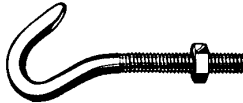

SCREW HOOKS



HEAVY HOOK LAG SCREW				
<ul style="list-style-type: none"> • ZINC PLATED STEEL 				
SIZE	HOOK OPENING	THREAD LENGTH	WIRE SIZE	PART
1/4 x 4-1/4	1	1-1/2	3	I 1172



MACHINE THREAD WITH NUT			
<ul style="list-style-type: none"> • ZINC PLATED STEEL 			
SIZE	HOOK OPENING	THREAD LTH	PART
3/16 x 2	1-1/8	1-3/16	R 60869
7/32 x 2-1/4	1-3/8	1-5/16	R 60870
1/4 x 2-5/8	1-1/2	1-5/8	R 60871
5/16 x 3-1/8	1-7/8	1-7/8	N 60872
3/8 x 3-3/4	2	2-1/4	L 60873

SCREW EYES

LARGE SCREW EYES				
<ul style="list-style-type: none"> ZINC PLATED STEEL  				
WIRE SIZE	OVERALL LENGTH	SHANK LENGTH	INSIDE DIA. EYE	PART
000	3-7/8	2-1/16	1-1/8	I 1138
0	2-7/8	1-9/16	13/16	I 1139
2	2-5/8	1-5/16	23/32	N 1140
4	2-3/16	1-1/8	39/64	N 1141
6	1-15/16	31/32	17/32	N 1142
9	1-9/16	3/4	7/16	R 1144
10	1-3/8	11/16	13/32	R 1145
12	1-3/16	37/64	3/8	R 1146
14	1-1/16	1/2	11/32	R 1147



MEDIUM SCREW EYES				
 				
WIRE SIZE	OVERALL LGTH	SHANK LGTH	INSIDE DIA. EYE	PART
4	2-1/16	1-1/8	31/64	T 1148
6	1-13/16	1	7/16	T 1149
8	1-9/16	13/16	25/64	T 1150
10	1-5/16	11/16	21/64	T 1151
12	1-1/8	19/32	9/32	T 1152
14	15/16	1/2	1/4	T 1153

SMALL SCREW EYES				
 				
WIRE SIZE	OVERALL LGTH	SHANK LGTH	INSIDE DIA. EYE	PART
4	1-15/16	1-1/8	19/64	T 1154
6	1-5/8	1	17/64	T 1155
8	1-3/8	13/16	15/64	T 1156
10	1-3/16	11/16	7/32	T 1157
12	15/16	37/64	3/16	T 1158
14	13/16	1/2	5/32	T 1159
16	11/16	7/16	9/64	T 1160

SMALL SCREW EYES SHORT SHANK				
 				
WIRE SIZE	OVERALL LGTH	SHANK LGTH	INSIDE DIA. EYE	PART
10	1	1/2	7/32	T 1161
12	3/4	3/8	3/16	T 1162
14	11/16	3/8	5/32	T 1163
16	9/16	9/32	9/64	T 1164
17	1/2	7/32	1/8	T 1165

HANGER BOLTS

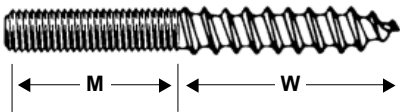
FULLY THREADED HANGER BOLTS

<ul style="list-style-type: none"> ONE END HAS WOOD SCREW THREAD AND THE OTHER END IS THREADED TO HOLD A NUT SCREWS ONE END INTO WOOD AND THE EXPOSED END PROVIDES A MACHINE THREADED STUD FOR CORNER BRACKETS, NUTS, HOOKS, ETC. 				 			
SIZE	MACHINE THREAD (M)	WOOD THREAD (W)	PART	SIZE	MACHINE THREAD (M)	WOOD THREAD (W)	PART
10-24 x 1-1/2	5/8	7/8	T 21120	5/16-18 x 2-1/2	1	1-1/2	R 21143
10-24 x 2	1	1	T 21122	5/16-18 x 3	1-1/2	1-1/2	R 21145
10-24 x 2-1/2	1	1-1/2	T 21123	5/16-18 x 3-1/2	1-1/2	2	R 21146
10-24 x 3	1-1/2	1-1/2	T 21124	5/16-18 x 4	2	2	R 21147
1/4-20 x 1-1/2	5/8	7/8	T 21126	3/8-16 x 2-1/2	1	1-1/2	N 21153
1/4-20 x 2	1	1	T 21128	3/8-16 x 3	1-1/2	1-1/2	N 21154
1/4-20 x 2-1/2	1	1-1/2	T 21130	3/8-16 x 3-1/2	1-1/2	2	N 21155
1/4-20 x 3	1-1/2	1-1/2	T 21132	3/8-16 x 4	2	2	N 21156

EXTRACTORS

MICRO POWER-OUT™ EXTRACTORS



The Micro Power-Out™ Extractor Set has many of the same features as our larger extractors but its design is a bit different. Put the micro tool into your reversible electric or battery powered drill, extractor side in, set it for reverse and drill your hole. Take the tool out, turn it around so that the drill side is inserted into the chuck and you have your extractor. Insert the extractor tip into the hole you just drilled and remove your broken screw. That's it! Fast, easy and dependable.

- SELF-CENTERING DRILL TIP
- SHORT, TOUGH DRILL BODY
- LEFT HAND CUTTING EDGE
- DRILL BIT AND EXTRACTOR IN ONE
- EASY, TIME SAVING OPERATION
- DRILLS GRADE 8 BOLTS

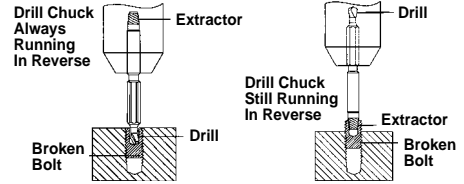

SIZE	DRILLING SPEED	EXTRACTING SPEED	PART
#5 and #6 (M3)	700-800 RPM	350 RPM (1/4 speed)	A 13084
#8 (M4)	650-750 RPM	470 RPM (1/3 speed)	A 13085
#10 (M5)	600-700 RPM	840 RPM (3/5 speed)	A 13086
1/4" (M6)	475-575 RPM	1400 RPM (full speed)	A 13087
Micro Drill-Out™ Extractor Set (4-Piece Set)			A 61616

POWER-OUT™ BROKEN BOLT EXTRACTORS

- QUICKLY AND EASILY REMOVES BROKEN BOLTS
- EASY, TIME SAVING OPERATION
- FAST AND REUSABLE
- SELF-CENTERING TIP
- LEFT HAND DRILL BIT AND EXTRACTOR IN ONE
- HEAT TREATED HIGH QUALITY TOOL STEEL
- USE IN A VARIABLE SPEED REVERSIBLE HAND DRILL



SIZE	DRILLING SPEED	EXTRACTING SPEED	PART
1/4" (M6)	700-800 RPM	350 RPM (1/4 speed)	A 13080
5/16" (M8)	650-750 RPM	470 RPM (1/3 speed)	A 13081
3/8" (M10)	600-700 RPM	840 RPM (3/5 speed)	A 13082
1/2" (M12)	475-575 RPM	1400 RPM (full speed)	A 13083
Power-Out™ Broken Bolt Extractor Kit (4-Piece Set)			A 61609

X-OUT™ DAMAGED SCREW REMOVER

- REMOVES STRIPPED PHILLIPS, TORX AND HEX SOCKET SCREWS, BUT CAN BE USED ON A VARIETY OF SCREW HEADS
- QUICK CHANGE SHANK FOR FAST, EASY TOOL CHANGES



SCREW DIA.	DRILLING SPEED	EXTRACTING SPEED	PART
#6 - #8	650-750 RPM	470 RPM (1/3 speed)	A 13096
#8 - #10	600-700 RPM	840 RPM (3/5 speed)	A 13097
#10 - #14	475-575 RPM	1400 RPM (full speed)	A 13098
X-Out™ Screw Remover Kit (3-Piece Set)			A 61623

MICRO AND POWER-OUT™ EXTRACTORS "COMPLETE SET"



Drill Bit and Extractor in One!

- Short, tough drill body allows flexibility & visibility
- Self-centering tip that will not walk or wander
- Left hand cutting edge (drill set for reverse)
- Requires a very shallow drill depth 1/4"-1/2" or 6mm - 12mm
- Extracts standard and metric sizes
- Drills up to & including grade 8 bolts or 10.9 class
- Warms the bolt up – easing the extraction process
- Uses the power of the drill to extract the bolt



COMPLETE SET CONTAINS:	PART
Broken Bolt Extractors: 5/16" (M8), 3/8" (M10) and 1/2" (M12)	A 61617
Micro Broken Bolt Extractors: #5 and #6 (M3), #8 (M4), #10 (M5) and 1/4" (M6)	

EXTRACTORS

SPIRAL SCREW EXTRACTORS



SIZE	SCREW SIZE	DRILL SIZE	PART
1	#8 to 1/4	5/64	A 13060
2	#12 to 5/16	7/64	A 13061
3	5/16 to 7/16	5/32	A 13062
4	7/16 to 9/16	1/4	A 13063
5	9/16 to 3/4	19/64	A 13064
6	3/4 to 1	13/32	A 13065
7	1 to 1-3/8	17/32	A 13066
8	1-3/8 to 1-3/4	13/16	A 13067
9	1-3/4 to 2-1/8	1-1/16	A 13068

SPIRAL SCREW EXTRACTOR SET CONTENTS

1 - 5 SPIRAL	A	13070	6 - 9 SPIRAL	A	13072
1 - 6 SPIRAL	A	13071	4 - 6 SPIRAL	A	13073

SQUARE SCREW EXTRACTORS

- MADE FROM RUGGED, HIGH CARBON STEEL TO HANDLE THE STRESS OF REMOVING BROKEN BOLTS
- IDEAL FOR SOFT MATERIALS OR THIN-WALLED PIECES SUCH AS PIPE AND FITTINGS
- WILL NOT EXPAND SOFT MATERIAL BEING REMOVED RESULTING IN EASIER REMOVAL
- GRIPS INTO SIDES OF DRILL HOLE AND REMOVES BROKEN PART WITHOUT DAMAGING THE THREADED HOLE



METHOD OF USE:

1. After drilling hole with either right or left handed drill bit, (left is recommended) insert extractor, turn counter clockwise.

SIZE	SCREW SIZE	DRILL SIZE	PART
1	3/16 to 5/16	9/64	A 13074
2	3/8	3/16	A 13075
3	7/16 and 1/8 NPT	15/64	A 13076
4	1/2 - 9/16 & 1/4 NPT	5/16	A 13077
5	5/8 and 3/8 NPT	3/8	A 13078

SQUARE SCREW EXTRACTOR SET CONTENTS

1 THROUGH 5 SQUARE	A	13069
--------------------	---	-------

DOUBLE EDGE SCREW EXTRACTORS

- Removes damaged screws and bolts without damaging threads
- Double edge can be used for both right and left hand drills
- Superior non-slip engagement with screw or bolt to be removed



P/N 12059
Includes Sizes #1 through #3



P/N 12060
Includes Sizes #1 through #5



SIZE	FOR USE ON BOLT SIZE	CHROMATE PILOT DRILL	PART
#1	#10 - 1/4"	11005 (1/8")	A 12061
#2	5/16" - 3/8"	11007 (3/16")	A 12062
#3	7/16" - 1/2"	11009 (1/4")	A 12063
#4	1/2" - 9/16"	11012 (11/32")	A 12064
#5	5/8" - 3/4"	11015 (7/16")	A 12065
#6	7/8" - 1"	*use 9/16"	A 12066
#7	1" - >1"	*use 3/4"	A 12067
3-Piece Set in Pouch (Includes Sizes #1 through #3)			A 12059
5-Piece Set in Pouch (Includes Sizes #1 through #5)			A 12060
Complete Set in a Metal Index (Includes Sizes #1 through #7)			A 61624



P/N 61624, Metal Index
Includes Sizes #1 through #7

* Special order only.

EXTRACTORS

TAP EXTRACTORS FOR MACHINE SCREWS AND HAND TAPS

- FOR MACHINE SCREW AND HAND TAPS
- REMOVES BROKEN TAPS WITHOUT DAMAGING THE THREADS OR REQUIRING A LARGER HOLE TO BE DRILLED
- TAP EXTRACTORS ARE MADE TO MATCH THE FLUTES OF THE TAPS – FINGERS FIT INTO FLUTES TO REMOVE THE BROKEN TAP SAFELY AND EFFECTIVELY
- SQUARE SHANK FITS STANDARD TAP HANDLES



1. Thoroughly remove all chips of the broken tap. Insert the extractor fingers into the flutes of the broken tap, pushing them gently but firmly into position.
2. Push the holder down until it touches the broken tap. Slide the sleeve down until it touches the work. (Both are important).
3. Apply a tap wrench to the square end of the holder. Twist forward and backward a few times to loosen, then back out the broken tap.



61637



61639

TAP SIZE	# FLUTES	PART	TAP SIZE	# FLUTES	PART	REPLACEMENT FINGERS	PART	REPLACEMENT FINGERS	PART
#4	3	A 12034	5/16	4	A 12019	For 12034	A 12034F	For 12019	A 12019F
#5	3	A 12035	3/8	4	A 12020	For 12035	A 12035F	For 12020	A 12020F
#6	3	A 12036	7/16	4	A 12021	For 12036	A 12036F	For 12021	A 12021F
#8	4	A 12015	1/2	4	A 12022	For 12015	A 12015F	For 12022	A 12022F
#10	4	A 12016	5/8	4	A 12023	For 12016	A 12016F	For 12023	A 12023F
#12	4	A 12017	3/4	4	A 12024	For 12017	A 12017F	For 12024	A 12024F
1/4	4	A 12018				For 12018	A 12018F		

TAP EXTRACTOR SETS:

6-Piece Set contains 1 each: 12016, 12018, 12019, 12020, 12021 and 12022

A

61637

61637CASE (Case Only)

13-Piece Set contains 1 each: 12034, 12035, 12036, 12015, 12016, 12017, 12018, 12019, 12020, 12021, 12022, 12023 and 12024

A

61639

61639CASE (Case Only)

PIPE AND STUD EXTRACTORS



- FOUR-POINT GRIP, WHICH ASSURES STRONG BITE
- SHALLOW GRIP, WHICH LESSENS EXPANSION AND JAMMING
- INSTANT RELEASE FROM BITE AFTER JOB IS COMPLETED
- RUST-RESISTANT BLACK OXIDE FINISH



PIPE EXTRACT. SIZE	BROKEN PIPE SIZE	BROKEN STUD OR SCREW SIZE	PART	PIPE EXTRACT. SIZE	BROKEN PIPE SIZE	BROKEN STUD OR SCREW SIZE	PART
#1	1/8	3/8	A 12041	#5	3/4	1-1/8 or 1-1/4	A 12045
#2	1/4	1/2	A 12042	#6	1"	1-1/2 or 1-3/4	A 12046
#3	3/8	5/8 or 3/4	A 12043	#7	1-1/4	2"	A 12047
#4	1/2	–	A 12044	#8	1-1/2	2-1/4 or 2-1/2	A 12048
#10	–	7/8 or 1"	A 12040	#9	2"	3 or 3-1/2	A 12049



61641

5-Piece Pipe Extractor Set in Plastic Case includes 12041, 12042, 12043, 12044, 12045

A

61628

61628CASE (Case Only)

7-Piece Pipe Extractor Set in Plastic Case includes 12040 through 12046

A

61641

EXTRACTORS

CIC 200™ BROKEN STUD REMOVAL KIT

Quickly and easily removes broken screws, studs, cap screws, pipe fittings, etc. Packed in a sturdy, metal index.

SPIRAL SCREW EXTRACTORS:

- HIGH CARBON STEEL CONSTRUCTION FOR STRENGTH AND DURABILITY
- SHARP SPIRAL FLUTES BITE QUICKLY INTO BROKEN STUD OR BOLT FOR SOLID GRIP
- REMOVES BROKEN STUDS OR BOLTS WITHOUT DAMAGING THREADS IN HOLE
- SAVES TIME, MONEY AND LABOR

LEFT HAND DRILLS:

- REVERSE DRILLING ACTUALLY THREADS OUT BROKEN STUDS OR BOLTS
- SPECIAL TOOL STEEL ALLOY FOR SUPERIOR STRENGTH, FASTER HEAT DISSIPATION AND LONGER LIFE
- EXTENDED FLUTES FOR FAST CHIP REMOVAL AND COOLER RUNNING
- CUTS STANDARD, STAINLESS, TOOL AND EXOTIC STEELS



CONTENTS		PART
SPIRAL EASY OUTS — #1, #2, #3, #4 and #5. USE TAP AND REAM ALIGNER P/N 8585	LEFT HAND DRILLS — 5/64, 7/64, 5/32, 1/4 and 19/64.	A 61676

INTERNAL PIPE WRENCHES

- FOR REMOVAL OF BROKEN THREADED ENDS OF PIPE, PIPE PLUGS AND FITTINGS
- HEX BODY CAN BE USED WITH A WRENCH
- PIPE SIZES ARE MARKED ON EACH WRENCH
- HEAT TREATED ALLOY STEEL, PLATED TO PREVENT RUST
- SIZE STAMPED ON BODY
- CONFORMS TO GOV. SPECS. GGG-W643B



SIZE	LENGTH	PART	
3/8" (9.7mm)	3-3/4" (95.25mm)	A	54481
1/2" (12mm)	3-3/4" (95.25mm)	A	54482
3/4" (20mm)	3-3/4" (95.25mm)	A	54483
1" (25mm)	3-3/4" (95.25mm)	A	54484
Internal Pipe Wrench Set (4-Piece Set) Sizes 3/8" to 1"		A	54480

AUTOMATIC CENTER PUNCH

- Press down on the handle to automatically strike a blow and mark centers
- Knurled cap turns to adjust stroke impact (light to heavy)
- Points are hardened tool steel and can be removed for regrinding and replacement



DESCRIPTION	PART	
5-1/4 Adjustable Auto-matic Center Punch	A	66430
Replacement Pin	A	66429

EXTRACTORS

IRWIN BOLT EXTRACTORS

- When you are faced with a rounded-off, rusted-tight or painted-over bolt, bolt extractors will break it free
- Reverse spiral flutes are designed to bite down to provide maximum gripping power
- High carbon steel ensures longer life and greater durability
- Universal lobular design fits all types of fasteners
- 3/8" & 1/2" square drive for use with hand ratchets, impact wrenches, and air ratchets
- Hexagonal flats for use with flat wrench, pliers, adjustable wrench, sockets or VISE-GRIP® locking pliers



**IRWIN
HANSON.**

DRIVE SIZE	REMOVES FRACTIONAL BOLTS	REMOVES METRIC BOLTS	DESCRIPTION	PART
3/8"	1/4"	N/A	1/4" Bolt Extractor	A 22151
3/8"	5/16"	8mm	5/16" & 8mm Bolt Extractor	A 22152
3/8"	3/8"	N/A	3/8" Bolt Extractor	A 22153
3/8"	N/A	10mm	10mm Bolt Extractor	A 22154
3/8"	7/16"	11mm	7/16" & 11mm Bolt Extractor	A 22155
3/8"	N/A	12mm	12mm Bolt Extractor	A 22156
3/8"	1/2"	N/A	1/2" Bolt Extractor	A 22157
3/8"	N/A	13mm	13mm Bolt Extractor	A 22158
3/8"	9/16"	14mm	9/16" & 14mm Bolt Extractor	A 22159
3/8"	5/8"	16mm	5/8" & 16mm Bolt Extractor	A 22160
3/8"	N/A	17mm	17mm Bolt Extractor	A 22161
3/8"	11/16"	N/A	11/16" Bolt Extractor	A 22162
3/8"	3/4"	19mm	3/4" & 19mm Bolt Extractor	A 22163
1/2"	3/4"	19mm	3/4" & 19mm Bolt Extractor	A 22164
1/2"	13/16"	21mm	13/16" & 21mm Bolt Extractor	A 22165
1/2"	7/8"	22mm	7/8" & 22mm Bolt Extractor	A 22166
1/2"	15/16"	24mm	15/16" & 24mm Bolt Extractor	A 22167
1/2"	1"	N/A	1" Bolt Extractor	A 22168



27

13 PIECE PROFESSIONAL SET

DESCRIPTION	PART
<ul style="list-style-type: none"> • Set includes bolt extractors to remove bolt sizes: <ul style="list-style-type: none"> - 1/4", 5/16", 3/8", 7/16", 1/2", 9/16", 5/8", 11/16", 3/4" - 8mm, 10mm, 11mm, 12mm, 13mm, 14mm, 16mm, 17mm, 19mm • Drive size: 3/8" • Plastic Case 	A 8881



P/N 8882



P/N 8883

5 PIECE BASE SET & 5 PIECE EXPANSION SET

DESCRIPTION	PART
Base Set: <ul style="list-style-type: none"> • Set includes bolt extractors to remove bolts sizes: <ul style="list-style-type: none"> - 3/8", 7/16", 1/2", 9/16", 5/8" and 11mm, 14mm, 16mm • Drive size: 3/8" • Includes most commonly used sizes • Plastic Case (accommodates expansion set P/N 8883) 	A 8882
Expansion Set: <ul style="list-style-type: none"> • Set includes bolt extractors to remove bolts sizes: <ul style="list-style-type: none"> - 5/16", 11/16", 3/4" and 8mm, 10mm, 13mm, 19mm • Drive size: 3/8" 	A 8883

EXTRACTORS

IRWIN HEX HEAD MULTI-SPLINE SCREW EXTRACTORS

- Designed to remove broken studs, bolts, socket screws and fittings for high torque applications
- Aggressive left-hand spiral design for extra gripping power



**IRWIN
HANSON.**

RECOMMENDED DRILL BIT DIA.	HEX HEAD SIZE	BOLT DIAMETER	DESCRIPTION	PART	
1/8"	1/2"	#12	1/8" Hex Head Multi-Spline Screw Extractor	A	22126
5/32"	1/2"	1/4"	5/32" Hex Head Multi-Spline Screw Extractor	A	22127
3/16"	1/2"	5/16"	5/32" Hex Head Multi-Spline Screw Extractor	A	22128
7/32"	1/2"	3/8"	7/32" Hex Head Multi-Spline Screw Extractor	A	22129
1/4"	1/2"	7/16"	1/4" Hex Head Multi-Spline Screw Extractor	A	22130
9/32"	1/2"	1/2"	9/32" Hex Head Multi-Spline Screw Extractor	A	22131
5/16"	1/2"	9/16"	5/16" Hex Head Multi-Spline Screw Extractor	A	22132
11/32"	1/2"	5/8"	11/32" Hex Head Multi-Spline Screw Extractor	A	22133
3/8"	1/2"	11/16"	3/8" Hex Head Multi-Spline Screw Extractor	A	22134
13/32"	1/2"	3/4"	13/32" Hex Head Multi-Spline Screw Extractor	A	22135
7/16"	5/8"	13/16"	7/16" Hex Head Multi-Spline Screw Extractor	A	22136
15/32"	5/8"	7/8"	15/32" Hex Head Multi-Spline Screw Extractor	A	22137
1/2"	5/8"	15/16"	1/2" Hex Head Multi-Spline Screw Extractor	A	22138
17/32"	3/4"	1"	17/32" Hex Head Multi-Spline Screw Extractor	A	22139
9/16"	3/4"	1-1/16"	9/16" Hex Head Multi-Spline Screw Extractor	A	22140
19/32"	3/4"	1-1/8"	19/32" Hex Head Multi-Spline Screw Extractor	A	22141
5/8"	3/4"	1-3/16"	5/8" Hex Head Multi-Spline Screw Extractor	A	22142
21/32"	7/8"	1-1/4"	21/32" Hex Head Multi-Spline Screw Extractor	A	22143
11/16"	7/8"	1-5/16"	11/16" Hex Head Multi-Spline Screw Extractor	A	22144
23/32"	7/8"	1-3/8"	23/32" Hex Head Multi-Spline Screw Extractor	A	22145
3/4"	7/8"	1-7/16"	3/4" Hex Head Multi-Spline Screw Extractor	A	22146
25/32"	1"	1-1/2"	25/32" Hex Head Multi-Spline Screw Extractor	A	22147
13/16"	1"	1-9/16"	13/16" Hex Head Multi-Spline Screw Extractor	A	22148
27/32"	1"	1-5/8"	27/32" Hex Head Multi-Spline Screw Extractor	A	22149
7/8"	1"	1-11/16"	7/8" Hex Head Multi-Spline Screw Extractor	A	22150

27



10 PIECE SET

DESCRIPTION	PART	
10 Piece Set Includes: • 1/8" through 13/32" • Plastic Case	A	8880

EXTRACTORS

IRWIN BOLT-GRIP™ DEEP WELL EXTRACTORS

- Deep well design fits over exposed studs & reaches recessed fasteners
- Reduced profile head enables use in confined spaces
- 3/8" square drive for use with hand ratchets, impact wrenches, and air ratchets
- Hexagonal flats for use with flat wrench, pliers, adjustable wrench, sockets, or VISE-GRIP® locking pliers
- When you are faced with a rounded-off, rusted-tight or painted-over bolt, these bolt extractors will break it free
- Reverse spiral flutes are designed to bite down to provide maximum gripping power
- High carbon steel ensures longer life and greater durability
- Universal lobular design fits all types of fasteners

IRWIN.

DRIVE SIZE	REMOVES FRACTIONAL BOLTS	REMOVES METRIC BOLTS	DESCRIPTION	PART	
3/8"	3/8"	N/A	3/8" Bolt-Grip™ Deep Well Extractor	A	22169
3/8"	7/16"	11mm	7/16" & 11mm Bolt-Grip™ Deep Well Extractor	A	22170
3/8"	1/2"	N/A	1/2" Bolt-Grip™ Deep Well Extractor	A	22171
3/8"	9/16"	14mm	9/16" & 14mm Bolt-Grip™ Deep Well Extractor	A	22172
3/8"	5/8"	16mm	5/8" & 16mm Bolt-Grip™ Deep Well Extractor	A	22173



5 PIECE SET	
DESCRIPTION	PART
Set Includes: <ul style="list-style-type: none"> • Deep Well extractors to remove bolts sizes: <ul style="list-style-type: none"> - 3/8", 7/16", 1/2", 9/16", 5/8" - 11mm, 14mm, 16mm, • Drive size: 3/8" • Plastic Case 	A 8884

EXTRACTORS

IRWIN POWER-GRIP™ SCREW & BOLT EXTRACTORS

- Easily removes damaged screws and bolts
- Designed for use with power tools
- 1/4" hex shank fits most drills and quick change adaptors
- When you are faced with a rounded-off, rusted-tight or painted-over bolt, these bolt extractors will break it free
- Reverse spiral flutes are designed to bite down to provide maximum gripping power
- High carbon steel ensures longer life and greater durability
- Universal lobular design fits all types of fasteners



IRWIN.

DRIVE SIZE	REMOVES FRACTIONAL BOLTS	REMOVES METRIC BOLTS	DESCRIPTION	PART
1/4"	3/16"	N/A	3/16" Power-Grip™ Screw & Bolt Extractor	A 22174
1/4"	1/4"	N/A	1/4" Power-Grip™ Screw & Bolt Extractor	A 22175
1/4"	5/16"	8mm	5/16" & 8mm Power-Grip™ Screw & Bolt Extractor	A 22176
1/4"	3/8"	N/A	3/8" Power-Grip™ Screw & Bolt Extractor	A 22177
1/4"	N/A	10mm	10mm Power-Grip™ Screw & Bolt Extractor	A 22178
1/4"	7/16"	11mm	7/16" & 11mm Power-Grip™ Screw & Bolt Extractor	A 22179
1/4"	1/2"	N/A	1/2" Power-Grip™ Screw & Bolt Extractor	A 22180



7 PIECE SET	
DESCRIPTION	PART
Set Includes: <ul style="list-style-type: none"> • Power-Grip bolt extractors remove bolt sizes: <ul style="list-style-type: none"> - 3/16", 1/4", 5/16", 3/8", 7/16", 1/2" - 8mm, 10mm, 11mm • Drive size: 1/4" hex shank • Plastic Case 	A 8885

CIC 200™ SUPERLOCK RECLOSABLE FASTENERS

ADHESIVE BACKED SELF-MATING STRIPS

- UNIQUE MUSHROOM SHAPED STEMS – SNAP TOGETHER FOR INSTANT, SECURE RECLOSABLE FASTENING
- ENGAGES TO ITSELF OR USE WITH SUPERLOCK DISCS – FOR UNLIMITED NUMBER OF APPLICATIONS
- HIGH BOND STRENGTH PRESSURE SENSITIVE ADHESIVE – PROVIDES EXCELLENT ADHESION AND RESISTANCE TO PLASTICIZER MIGRATION
- WIDE TEMPERATURE RANGE PERFORMANCE SUPPORTS STATIC LOADS FROM -20°F to 200°F
- DURABLE CONSTRUCTION – MAINTAINS EXCELLENT DISENGAGEMENT STRENGTH ASSURING OVER 1000 CLOSURES
- UV RESISTANT FOR DURABILITY AND LONG LIFE
- ADHERES TO: BARE METALS, PAINTED METALS, GLASS, FIBERGLASS, SEALED WOOD, ABS, ACRYLIC, POLYCARBONATE, POLYSTYRENE, RIGID VINYL AND PLASTICIZED VINYL



DESCRIPTION	DISENGAGEMENT STRENGTH		PART
1" x 6" SUPERLOCK RECLOSABLE FASTENER (STRIPS)	38 LBS.	J	2884
1" x 15 FEET SUPERLOCK RECLOSABLE FASTENER (CONTINUOUS ROLL)	38 LBS.	A	2883

ROUND SELF-MATING DISCS

- RIGID POLYOLEFIN CONSTRUCTION – PROVIDES POSITIVE LOCKING, RECLOSABLE FASTENING FOR ATTACHING REMOVABLE DECORATIVE PANELS, COWLINGS, ACCESS PANELS, ETC.
- EASILY MOUNTED WITH METAL, WOOD OR MACHINE SCREWS
- MAINTAINS EXCELLENT DISENGAGEMENT STRENGTH – PROVIDING OVER 1000 RECLOSURE CYCLES

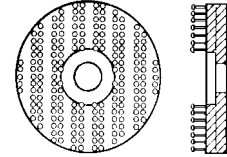

DESCRIPTION	TENSILE STRENGTH	CLEAVAGE STRENGTH	SHEAR STRENGTH	PART
1-3/16" DIAMETER SUPERLOCK RECLOSABLE FASTENERS	35 LBS.	22 LBS.	4 LBS.	R 2888

SUGGESTED MOUNTING SCREWS FOR ROUND SUPERLOCK DISCS

DESCRIPTION	SIZE		PART
PHILLIPS BINDING HEAD METAL SCREW	6 x 1/2	U	1507
	6 x 3/4	U	1509
SLOTTED ROUND HEAD WOOD SCREW	6 x 1/2	U	8509
	6 x 3/4	U	8511

SUPERLOCK LITE RECLOSABLE FASTENERS

- SAVES TIME AND MONEY – EASY TO INSTALL, HOOK AND LOOP ALL IN ONE
- REUSABLE – CAN BE USED AGAIN AND AGAIN FOR MAXIMUM EFFICIENCY
- VERSATILE – CAN BE CUT TO ANY LENGTH
- SECURES QUICKLY AND EASILY – REMAINS LOCKED WITHOUT SLIPPING
- IDEAL FOR USE ON CABLE AND WIRE ASSEMBLIES, FIBER OPTIC INSTALLATIONS OR BUNDLING AND WRAPPING OF MANY ITEMS
- RATED TO TEMPERATURES UP TO 212°F (100°C)
- THICKNESS = 33 MILS (0.033 INCHES)
- SHEAR STRENGTH = 20 PSI • TENSILE STRENGTH = 40 LBS (1/2" WIDTH)



DESCRIPTION	PART
1/2" x 25 YARD SUPERLOCK LITE	A 32886
1" x 25 YARD SUPERLOCK LITE	A 32887
8" SUPERLOCK LITE STRAPS – (3/4" x 25 yard approx. 112 pieces per roll)	A 32888
DISPENSER	A 32883

BUMPERS

APPLIES QUICKLY AND EASILY WHEREVER PROTECTION IS NEEDED

<ul style="list-style-type: none"> • UL RECOGNIZED COMPONENT • EASY "PEEL-OFF" BACKING • SUPERIOR ABRASION RESISTANCE • CRACK-RESISTANT AND RESILIENT • NON-STAINING AND NON-MARRING • VIBRATION AND SHOCK DAMPENING • SUPERB COEFFICIENT OF FRICTION AND RESISTANCE TO SKIDDING • CONTAINS NO PLASTICIZERS, OILS OR FILLERS <p>APPLICATIONS: Cutting Boards, Picture Frames, Cabinet Doors, Sliding Doors, Computers, Appliances, Office Equipment, Desktop Calculators</p>		DESCRIPTION	COLOR	PART
		.14 x .50 Cylindrical	Clear	U 62730
		.15 x .375 Hemispherical	Clear	U 62731
		.25 x .50 Cylindrical	Clear	U 62732
		.14 x .50 Cylindrical Recessed	Clear	U 62733
		.125 x .375 Cylindrical	Black	V 62734
		.23 x .50 Square	Black	U 62735
		.30 x .81 Square	Black	T 62736
		.40 x .88 Circular Recessed	Black	T 62737
		.60 x 1.81 Circular Recessed	Clear	I 62738

MAGNETIC TOOLS

MAGNETIZER/DEMAGNETIZER

The Magnetizer/Demagnetizer is ideal for use with screwdrivers, nut drivers, wrenches, tweezers, and other steel tools. The simple yet powerful design quickly converts any tool blade into a magnetic retrieval tool. The Magnetizer/Demagnetizer can also be used to remove magnetism from tools and make them safe for use with sensitive electronics.



- For use with screwdrivers, nut drivers, taps, wrenches and other steel objects
- Magnetizer turns bladed tools into powerful retrieval tools
- Demagnetizer makes tools safe for use with electronic equipment
- Great for magnetizing a screwdriver when working with small fasteners



TO MAGNETIZE

Insert the blade of the tool into the opening of the Magnetizer/Demagnetizer and slide back and forth. Continue this procedure until you reach the desired level of magnetism.



TO DEMAGNETIZE

Rub the blade of the tool along the outside of the Magnetizer/Demagnetizer. Continue this procedure until the tool is completely demagnetized.

Magnetizer Demagnetizer

A 66424

MAGNETIC STUD FINDER

- Positively locates screws and steel studs with powerful rare earth magnets
- Easily locates studs and screws
- Rotating vial for level and plumb
- Guaranteed No False Positives - Magnet sticks to screw or steel stud
- No batteries required
- Will pull itself to a nail or screw



DESCRIPTION

PART

Magnetic Stud Finder

A 66396

HEAVY-DUTY MAGNETIC PICK-UP TOOL

- THIS POWERFUL RARE EARTH MAGNET QUICKLY AND SAFELY PICKS UP METAL CHIPS, FASTENERS, NUTS AND BOLTS AND MORE

- SIMPLY WAVE OVER DEBRIS AND RELEASE BY PULLING THE KNOB



DESCRIPTION

PART

Heavy Duty Magnetic Pick-Up Tool

A 66395

CHAIN LINKS

CONNECTING AND OFFSET LINKS

17743

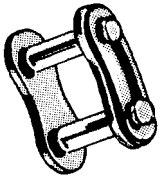

CONNECTING LINKS

- **LEAKPROOF LUBRICATION**
PROVIDES TWO TO ONE LONGER LIFE OVER CONVENTIONAL CURLED BUSHING ROLLER CHAINS, EVEN IN THE MOST SEVERE APPLICATIONS
- **COLD FORMED, ONE-PIECE CONSTRUCTION**
FOR BETTER FATIGUE CHARACTERISTICS, PROVIDING MINIMAL INITIAL ELONGATION AND LONGER LIFE
- **UNIFORMITY OF CONTACT POINT BETWEEN PIN AND BUSHING**
INCREASES WEAR RESISTANCE AND DECREASES ELONGATION

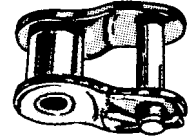

OFFSET LINKS

CONNECTING		PART	OFFSET		PART
#35	L	60490	#35	I	60480
#40	L	60491	#40	I	60481
#41	L	60492	#41	I	60482
#50	L	60493	#50	I	60483
#60	I	60494	#60	F	60484
#80	I	60495	#80	D	60485
#120	D	60496	#120	B	60486

ELASTIC SHOCK CORD AND HOOKS

MAKE ANY LENGTH SHOCK CORD

27

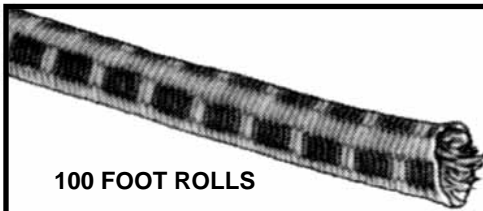

100 FOOT ROLLS



P/N 60380 (Nylon)



P/N 60381 (Nylon)



P/N 60382 / 60383 (Metal) (Includes Hog Rings)



- **MAKE SHOCK CORD ASSEMBLIES IN THE EXACT LENGTH YOU NEED BY CUTTING TO DESIRED LENGTH AND ATTACHING HOOKS.**
- **RESILIENT, MULTI-STRAND RUBBER CORE GIVES SHOCK CORD MAXIMUM STRETCH WITHOUT BREAKING.**
- **WHITE NYLON COVERED CORD IS STRONGER THAN POLYPROPYLENE TYPES AND RESISTS SALT WATER AND CHLORINE.**
- **MOLDED SHOCK CORD HOOKS (P/N'S 60380 AND 60381) ARE RUST AND CORROSION PROOF ELIMINATING THE TRADITIONAL METAL CRIMP RING. THEY SECURELY GRIP BY MEANS OF A PATENTED FASTENING MECHANISM. THE SLIP RING CONCEALS THE END OF THE SHOCK CORD, GIVING IT A CLEAN, FINISHED APPEARANCE.**



SIZE	COLOR		HOOK PART #		SHOCK CORD PART #
1/4" x 100'	White with Black Stripe	R	60380	A	60374
5/16" x 100'	White with Yellow Stripe	Q	60381	A	60375
3/8" x 100'	White with Red Stripe	Q	60382	A	60376
1/2" x 100'	White with Blue Stripe	Q	60383	A	60377

GRADE 30 WELDED PROOF COIL CHAINS

- LOW CARBON STEEL UTILITY CHAIN
- A WIDE RANGE OF GENERAL PURPOSE USES
- ZINC PLATED
- USED FOR TOWING, LOGGING AND BINDING
- ASTM A391 AND ASTM A413



SIZE	WORK LOAD LIMIT	PART	SIZE	WORK LOAD LIMIT	PART
1/4 x 75 Ft.	1,300 Lbs.	A 60505	3/8 x 35 Ft.	2,650 Lbs.	A 60507
5/16 x 50 Ft.	1,900 Lbs.	A 60506	-	-	-

QUICK LINKS

- ZINC PLATED
- FAST, EASY CONNECTIONS
- USE AS REPAIR LINK, CONNECTING LINK OR ATTACHING DEVICE
- STANDARD JAW



CHAIN SIZE	WORK LOAD LIMIT	GAP	INSIDE WIDTH	INSIDE LENGTH	PART
1/4	880 Lbs.	9/32	9/16	1-3/4	I 60500
5/16	1,540 Lbs.	3/8	11/16	2-5/16	I 60501
3/8	1,980 Lbs.	7/16	3/4	2-7/16	E 60502
1/2	3,300 Lbs.	19/32	15/16	3-3/16	B 60503

CLEVIS GRAB HOOKS

- GRADE 43
- MADE FOR USE WITH PROOF COIL CHAIN (GRADE 30)
- HEAT TREATED – HIGH TEST STAMPED ON EVERY HOOK

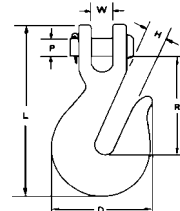

CHAIN SIZE	WORK LOAD LIMIT	W	D	H	L	P	R	PART
1/4	2,600 Lbs.	5/16	1-15/16	3/8	3-3/8	5/16	2	A 60510
5/16	4,000 Lbs.	3/8	2-1/4	7/16	3-15/16	3/8	2-3/8	A 60511
3/8	5,400 Lbs.	7/16	2-11/16	1/2	4-1/2	7/16	2-11/16	A 60512
1/2	9,200 Lbs.	19/32	3-5/16	21-32	5-39/64	9/16	3-23/64	A 60517

27

CLEVIS SLIP HOOKS

- GRADE 43
- MADE FOR USE WITH PROOF COIL CHAIN (GRADE 30)
- HEAT-TREATED

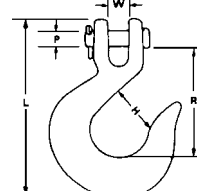

CHAIN SIZE	WORK LOAD LIMIT	W	H	P	R	PART
1/4	2,600 Lbs.	5/16	15/16	11/32	2-5/16	A 60513
5/16	4,000 Lbs.	3/8	1-1/16	13/32	2-9/16	A 60514
3/8	5,400 Lbs.	7/16	1-1/4	1/2	3	A 60515
1/2	9,200 Lbs.	19/32	1-3/4	9/16	3-15/16	A 60516

MACHINERY EYE BOLTS – SHOULDER PATTERN

- DESIGNED FOR LIFTING
- HOT GALVANIZED DROP FORGED
- MADE OF C-1035 STEEL
- COARSE THREAD CLASS 2A
- SHOULDER PATTERN



DIA.	SHANK LENGTH	MAX. LENGTH	MAX. WORK LOAD LIMIT LBS.	PART	DIA.	SHANK LENGTH	MAX. LENGTH	MAX. WORK LOAD LIMIT LBS.	PART
1/4	1	3	500	I 60540	5/8	1-3/4	4-1/2	4,000	D 60546
5/16	1-1/8	4	900	I 60541	3/4	2	5	5,000	B 60547
3/8	1-1/4	4-1/2	1,300	I 60542	7/8	2-1/4	5	7,000	A 60548
7/16	1-3/8	4-1/2	2,000	E 60543	1	2-1/2	5	9,000	A 60549
1/2	1-1/2	4-1/2	2,400	E 60544	-	-	-	-	-

U-BOLT WITH PLATE

- USED TO SECURE PIPE, HOSE AND TUBING IN VARIOUS STRUCTURAL MOUNTING APPLICATIONS
- STEEL ZINC PLATED
- MADE IN USA



DIAMETER	WIDTH	LENGTH	PART	DIAMETER	WIDTH	LENGTH	PART
1/4	9/16	1-1/4	I 60560	5/16	1-3/4	4-1/2	I 60577
1/4	3/4	1-1/4	I 60561	5/16	2	2-11/16	I 60578
1/4	3/4	2-1/4	I 60562	5/16	2	4-3/4	I 60579
1/4	1	1-3/4	I 60563	3/8	1-1/4	2-1/4	I 60583
1/4	1	2-3/4	I 60564	3/8	1-1/2	2-1/2	E 60585
1/4	1-1/8	2	I 60565	3/8	2	2-5/8	E 60587
1/4	1-1/8	3-1/8	I 60566	3/8	2-1/2	3-1/8	E 60588
1/4	1-1/4	2-1/4	I 60567	3/8	3	6-5/8	E 60590
1/4	1-1/2	2-3/4	I 60568	1/2	3	4-1/2	B 60592
1/4	1-3/4	3	I 60569	1/2	3-1/2	8-1/2	B 60594
1/4	2	3-1/4	I 60570	1/2	4-1/2	6	B 60596
5/16	1	2-3/16	I 60571	-	-	-	-

WIRE ROPE CLIPS

MALLEABLE:

- PRECISION MANUFACTURED AND GALVANIZED
- MEETS FEDERAL SPECIFICATIONS FF-C-450, TYPE 1, CLASS 2
- SHOULD BE USED IN LIGHT DUTY, NON-CRITICAL APPLICATIONS ONLY



DROP FORGED:

- PRECISION MANUFACTURED AND GALVANIZED
- MEETS FEDERAL SPECIFICATIONS FF-C-450, TYPE 1, CLASS 1
- FOR HEAVY DUTY APPLICATIONS



MALLEABLE

ROPE SIZE	TYPE	PART	ROPE SIZE	TYPE	PART
1/8	Galvanized	E 12000	1/8	Plain	I 12003
3/16	Galvanized	E 12001	3/16	Plain	I 12004
1/4	Galvanized	E 12002	1/4	Plain	I 12005

DROP FORGED

ROPE SIZE	TYPE	PART	ROPE SIZE	TYPE	PART
5/8	Galvanized	B 12006	1/4	Galvanized	E 12010
3/4	Galvanized	A 12007	5/16	Galvanized	E 12011
1/8	Galvanized	E 12008	3/8	Galvanized	B 12012
3/16	Galvanized	E 12009	1/2	Galvanized	B 12013

TURNBUCKLES

EYE & EYE AND HOOK AND EYE

- MAXIMUM STRENGTH AND EASY ADJUSTMENT OF WIRE ROPE ATTACHMENTS
- HOT DIP GALVANIZED
- FORGED BODY
- HEAT TREATED
- MEETS SPECIFICATIONS FF-T-791B, TYPE 1, FORM 1, EYE & EYE CLASS 4 AND HOOK & EYE CLASS 6



EYE & EYE



HOOK & EYE

EYE AND EYE

THREAD DIA.	TYPE	PART	THREAD DIA.	TYPE	PART
3/8 x 6	Plain	A 11196 (Round)	5/8 x 9	Galvanized	A 11205 (Tear Drop)
1/2 x 6	Plain	A 11197 (Round)	1/4 x 4	Plain	A 11206 (Tear Drop)
5/8 x 9	Plain	A 11198 (Round)	5/16 x 4-1/2	Plain	A 11207 (Tear Drop)
5/8 x 12	Plain	A 11199 (Round)	3/8 x 6	Galvanized	A 11208 (Tear Drop)
-	-	-	1/2 x 6	Plain	A 11209 (Tear Drop)

HOOK AND EYE

THREAD DIA.	TYPE	PART	THREAD DIA.	TYPE	PART
1/4 x 4	Plain	A 11200	1/2 x 6	Plain	A 11203
5/16 x 4-1/2	Plain	A 11201	1/2 x 9	Plain	A 11204
3/8 x 6	Plain	A 11202	-	-	-

SHAFT COLLARS

SET SCREW SHAFT COLLAR

- HEX SOCKET SET SCREW LOCKS SHAFT
- ZINC PLATED AND STAINLESS STEEL

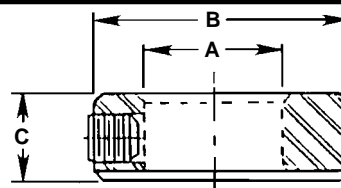

NOMINAL DIA.	MIN. (A)	MAX. (A)	OD (B)	WIDTH (C)	SET SCREW	ZINC PLATED	STAINLESS
1/8	.1260	.1280	3/8	1/4	6-32	L 3800	E 23800
3/16	.1885	.1905	7/16	1/4	8-32	L 3801	E 23801
1/4	.2510	.2530	1/2	5/16	10-32	L 3802	E 23802
5/16	.3135	.3155	5/8	5/16	10-32	L 3803	E 23803
3/8	.3760	.3780	3/4	3/8	1/4-20	L 3804	E 23804
7/16	.4385	.4405	7/8	7/16	1/4-20	L 3805	E 23805
1/2	.5010	.5030	1	7/16	1/4-20	L 3806	E 23806
9/16	.5635	.5655	1	7/16	1/4-20	L 3807	B 23807
5/8	.6260	.6280	1-1/8	1/2	5/16-18	I 3808	B 23808
11/16	.6885	.6905	1-1/4	9/16	5/16-18	I 3809	B 23809
3/4	.7510	.7530	1-1/4	9/16	5/16-18	I 3810	B 23810
13/16	.8135	.8155	1-1/2	9/16	5/16-18	I 3811	B 23811
7/8	.8760	.8780	1-1/2	9/16	5/16-18	I 3812	B 23812
15/16	.9385	.9504	1-5/8	5/8	5/16-18	I 3813	A 23813
1	1.0010	1.0030	1-5/8	5/8	5/16-18	I 3814	A 23814
1-1/16	1.0635	1.0665	1-3/4	5/8	5/16-18	I 3815	A 23815
1-1/8	1.1260	1.1290	1-3/4	5/8	5/16-18	I 3816	A 23816
1-3/16	1.1885	1.1915	2	11/16	3/8-16	I 3817	A 23817
1-1/4	1.2510	1.2540	2	11/16	3/8-16	I 3818	A 23818
1-3/8	1.3760	1.3790	2-1/8	3/4	3/8-16	I 3820	A 23820
1-1/2	1.5010	1.5040	2-1/4	3/4	3/8-16	I 3822	A 23822
1-5/8	1.6260	1.6290	2-1/2	13/16	3/8-16	E 3824	A 23824
2	2.0010	2.0040	3	7/8	1/2-13	E 3830	A 23830
2-5/16	2.3135	2.3165	3-1/4	15/16	1/2-13	A 3834	A 23834

SHAFT COLLARS (Cont'd.)

CLAMP TYPE SHAFT COLLAR

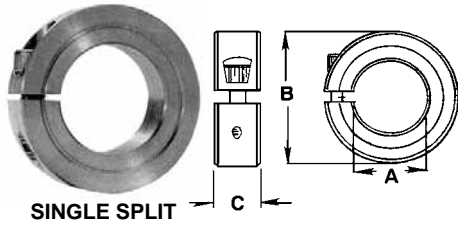

SINGLE SPLIT

- CLAMP DESIGN PROVIDES A FULL RADIAL HOLD ON SHAFT
- TIGHTEN CAP SCREW TO SECURE
- GREATER CLAMPING FORCE THAN SET SCREW SHAFT COLLARS
- BLACK OXIDE

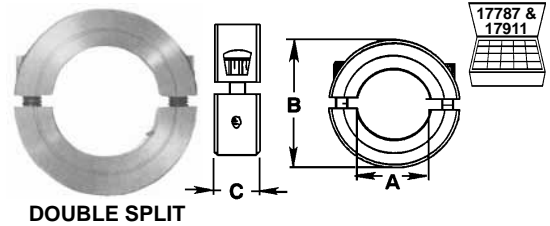

DOUBLE SPLIT

NOMINAL BORE (A)	OD (B)	WIDTH (C)	CLAMP SCREW (D)	SINGLE SPLIT	DOUBLE SPLIT
3/16	5/8	.313	4-40	I 3835	B 23900
1/4	.688	.313	4-40	I 3836	B 23901
5/16	11/16	.313	4-40	I 3837	B 23902
3/8	7/8	.343	6-32	I 3838	B 23903
7/16	15/16	.375	6-32	I -	B 23904
1/2	1-1/8	.406	8-32	I 3840	B 23905
9/16	1-1/4	.437	10-32	E -	B 23906
5/8	1-5/16	.437	10-32	E 3842	B 23907
11/16	1-3/8	.437	10-32	-	B 23908
3/4	1-1/2	1/2	1/4-28	3844	B 23909
13/16	1-5/8	1/2	1/4-28	-	B 23910
7/8	1-5/8	1/2	1/4-28	-	B 23911
15/16	1-3/4	1/2	1/4-28	-	B 23912
1	1-3/4	1/2	1/4-28	3848	B 23913
1-1/16	1-7/8	1/2	1/4-28	-	B 23914
1-1/8	1-7/8	1/2	1/4-28	-	B 23915
1-3/16	2-1/16	1/2	1/4-28	-	B 23916
1-1/4	2-1/16	1/2	1/4-28	-	B 23917
1-5/16	2-1/8	9/16	1/4-28	-	B 23918
1-3/8	2-1/4	9/16	1/4-28	-	B 23919
1-7/16	2-1/4	9/16	1/4-28	-	B 23920
1-1/2	2-3/8	9/16	1/4-28	-	B 23921
1-9/16	2-3/8	9/16	1/4-28	-	B 23922
1-5/8	2-5/8	11/16	5/16-24	-	A 23923
1-11/16	2-3/4	11/16	5/16-24	-	A 23924
1-3/4	2-3/4	11/16	5/16-24	-	A 23925
1-13/16	2-7/8	11/16	5/16-24	-	A 23926
1-7/8	2-7/8	11/16	5/16-24	-	A 23927
1-15/16	3	11/16	5/16-24	-	A 23928
2	3	11/16	5/16-24	-	A 23929
2-1/16	3-1/8	3/4	5/16-24	-	A 23930
2-1/8	3-1/4	3/4	5/16-24	-	A 23931
2-3/16	3-1/4	3/4	5/16-24	-	A 23932
2-1/4	3-1/4	3/4	5/16-24	-	A 23933
2-5/16	3-3/8	3/4	5/16-24	-	A 23934
2-3/8	3-1/2	3/4	5/16-24	-	A 23935
2-7/16	3-1/2	3/4	5/16-24	-	A 23936
2-1/2	3-3/4	7/8	3/8-24	-	A 23937
2-9/16	3-7/8	7/8	3/8-24	-	A 23938
2-5/8	3-7/8	7/8	3/8-24	-	A 23939
2-11/16	4	7/8	3/8-24	-	A 23940
2-3/4	4	7/8	3/8-24	-	A 23941
2-13/16	4-1/4	7/8	3/8-24	-	A 23942
2-7/8	4-1/4	7/8	3/8-24	-	A 23943
2-15/16	4-1/4	7/8	3/8-24	-	A 23944
3	4-1/4	7/8	3/8-24	-	A 23945

TIE-DOWNS

STRETCH-N-SECURE FLEX CORD

Features

- Industry standard 8 mm core
- Latex rubber core covered in a weather resistant braid combined with a high quality molded hook with safety hasp
- These bungee cords will stay put and will not scratch
- Stretches up to 50%
- UV protected
- Weather resistant

Applications

- Power cords • Hoses • Pipes • Wood Piles



DESCRIPTION	PART
40" Length - Blue Cord	A 60378
24" Length - Yellow Cord	A 60379

RUBBER HOLD DOWN STRAPS

- 2 TO 1 STRETCH RATIO
- 100 % RUBBER
- REINFORCED EYELETS
- 2 PLATED "S" HOOKS INCLUDED



LENGTH	PART
10"	60385
15"	60386
21"	60387
31"	60388

ROPE RATCHETS

- UNIQUE, COMPACT RATCHET SYSTEM SECURES A WIDE VARIETY OF ITEMS QUICKLY AND EASILY
- QUICKLY SECURE ITEMS TIGHTLY WITHOUT SLIPPING
- RELEASES WITH THUMB LEVER
- NO COMPLICATED KNOTS TO TIE AND UNTIE
- WILL NOT STRETCH LIKE ELASTIC CORDS
- TOUGH, WEATHER RESISTANT NYLON ROPE
- WILL WORK WITH COMPARABLE SIZE ROPE OR CORD



SIZE	MAX. LOAD	PART
1/8 x 6'	75 LB.	A 60395
1/4 x 10'	150 LB.	A 60396
3/8 x 10'	250 LB.	A 60397
1/2 x 10'	500 LB.	A 60398

KWIKTWIST® GIANT WIRE TIES

Features

- 32" Length
- 1/2" Diameter
- Will not scratch surfaces
- Won't stretch or break
- Holds up to 100 lbs
- Safer than bungees
- Reusable
- Floats
- UV resistant
- Threaded ends
- Create your own lengths

Uses

- Secure gates and fences
- Secure items on boats
- Secure animal trailers
- Secure animal carriers
- Organize storage
- Organize garages
- Organize trucks
- Hang hoses & tools
- Hang work lights
- Hang water & feed buckets
- Hang or extend plant baskets
- Tie down tarps & covers
- Tie back trees and shrubs
- Tidy up computer cables
- Bundle up lawn furniture

KWIK as 1 2 3



For maximum strength, be sure to use 3 twists!

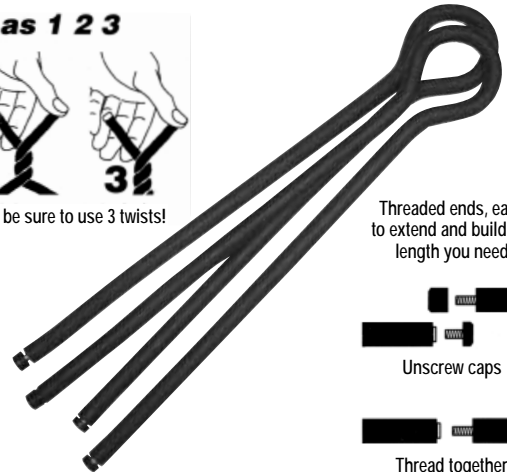

Threaded ends, easy to extend and build the length you need



Unscrew caps



Thread together

SIZE	COLOR	PART
32" X 1/2"	Black	B 60367
32" X 1/2"	Red	B 60368
32" X 1/2"	Blue	B 60369

RUBBER GROMMETS

USE FOR INSULATING, VIBRATION DAMPING, SEALING AND ABRASION CONTROL

- USE FOR INSULATING, VIBRATION DAMPENING, SEALING, ABRASION CONTROL AND ELECTRICAL CORD PROTECTION
- MADE FROM A BLACK NATURAL RUBBER BASE COMPOUND
- HARDNESS IS 50-60 SHORE A DUROMETER
- TEMPERATURE RESISTANT TO 180°F

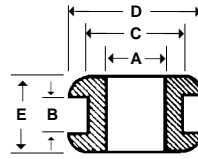

A I.D. BORE	B GROOVE WIDTH	C GROOVE DIA.	D O.D. DIA.	E OVERALL THICKNESS	PART	A I.D. BORE	B GROOVE WIDTH	C GROOVE DIA.	D O.D. DIA.	E OVERALL THICKNESS	PART
5/32	1/16	1/4	3/8	3/16	T 62700	3/8	1/16	1"	1-1/4	1/4	N 62712
3/16	1/16	5/16	1/2	1/4	R 62701	3/8	1/8	5/8	7/8	3/8	R 62713
3/16	3/32	9/32	7/16	7/32	T 62702	3/8	1/4	5/8	7/8	1/2	R 62714
3/16	1/4	5/16	7/16	3/8	T 62703	1/2	3/32	3/4	31/32	9/32	N 62715
15/64	3/16	3/8	5/8	3/8	N 62704	1/2	3/32	25/32	1-1/16	11/32	N 62716
1/4	1/16	3/8	1/2	7/32	T 62705	1/2	1/8	3/4	1	1/2	N 62717
1/4	1/16	7/16	5/8	3/16	T 62706	1/2	1/4	13/16	1-1/16	1/2	N 62718
5/16	1/16	7/16	9/16	3/16	R 62707	5/8	1/8	7/8	1-1/8	3/8	N 62719
5/16	1/16	3/4	1"	5/16	N 62708	5/8	1/16	7/8	1-1/8	5/16	R 62720
5/16	1/8	9/16	13/16	3/8	R 62709	3/4	1/16	1-1/16	1-3/8	3/8	N 62721
5/16	1/4	9/16	13/16	1/2	R 62710	3/4	1/4	1-1/4	1-5/8	7/16	I 62722
3/8	1/16	1/2	5/8	1/4	T 62711	1"	1/16	1-3/8	1-3/4	7/16	I 62723

WIPES

ALL-PURPOSE WIPERS FOR ALL MAINTENANCE APPLICATIONS

- Made from highly absorbent fibers that provides strength and soft, cloth-like feel
- Designed for soaking-up oil, grease or water based fluids on hands, small parts, machinery, etc.
- Economical – can be used over and over



Applications:

- Metal industries – metal stamping, lathes, cnc machines, screw machines
- Automotive manufacturing and support industries
- Plastics – injection and blow molding
- Commercial printing and general manufacturing

DESCRIPTION	PART
Quarter Fold Wipers 50/Pack	D 28225

SUPER PREP TOWEL

- Reusable cloth-like towel wipes dry and virtually lint free
- High performance
- Chemically pure – binder & contaminant free
- Ideal rag replacement towel
- Convenient portable tote box With rugged handle
- Absorption rate = 6x dry weight
- Highly absorbent in aqueous Liquids, oil and solvents
- Solvent resistant – won't breakdown In most aggressive solvents



DESCRIPTION	PART
Super Prep Towels – 200 Count	A 28220

HI-PER WIPES

- Professional quality, all-purpose Bonded cellulose wipers
- Ideal for general purpose wiping
- Ultra absorbent – wipes Totally dry
- Low lint and solvent resistant
- Convenient portable tote box With rugged handle



DESCRIPTION	PART
Hi-Per Wipes – 225 Count	A 28221

SANDWICH ERASER SPONGE – INDUSTRIAL MELAMINE* CLEANING TOOL

Features

- The design is 2 parts melamine foam (white) and a polyurethane center (blue).
- Great for use on any water washable surface to remove a variety of soils and stains.
- Twice the amount of cleaning surface plus blue durability strip means longer useful life.
- Handles a wide range of cleaning tasks eliminating the need for multiple cleaning products.
- Great for really tough jobs!

For use on

- Tables
- White boards
- Counters
- Walls
- Scuffs on floors
- Scuffs on seats
- Sinks
- Lavatory surfaces
- Tile
- Lighting fixtures
- Light graffiti removal
- Any other surface that needs cleaning including painted surfaces

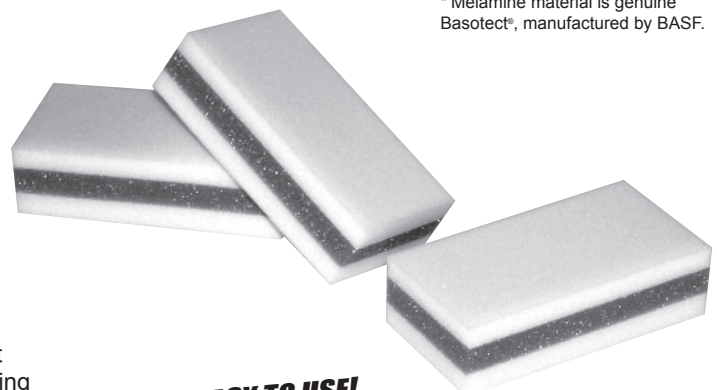

* Melamine material is genuine Basotect®, manufactured by BASF.

**EASY TO USE!
USE ONLY WATER!
NO CHEMICALS REQUIRED!**

DESCRIPTION	PART
Sandwich Eraser Sponge (200 pcs.)	U 28238
Sandwich Eraser Sponge (10 pcs.)	I 28238-10

WIPES

1-2-3 TOWEL

Features

- A hygienic towel
- Made from cellulose cotton fiber
- Biodegradable
- Environmentally safe
- Great large size of 9" x 10"
- Comes in a convenient pack of 10

Applications

- Construction sites
- Medical / Fire & Rescue
- Military
- Commercial

Just Add Water!

When you're ready to freshen up, simply wet, unfold, and use. It's as easy as 1, 2, 3!



DESCRIPTION

1-2-3 Towel (9" x 10")

PART

A 85093

MICROFIBER WIPES

Perfect for all industries, including janitorial, sanitation, housekeeping, daycare centers, automotive, hospitals, nursing homes, etc.

Features

- Microfiber outperforms and outlasts cotton cloth towels.
- Machine washable and reusable, reduces paper waste disposal.
- Extremely durable, lasts through more washes per towel.
- More absorbent than traditional cotton or paper towels

Specifications

- 80% Polyester / 20% Polyamide (Nylon)
- 16" x 16" (40.64 cm x 40.64 cm)
- 50 grams – Microfiber is so absorbent that over time, a "dry" towel can actually increase in weight!

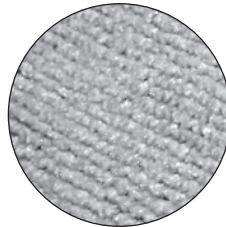

DESCRIPTION

Microfiber Wipes, 12/Pack – Blue

PART

J 28233

WIPES

HAND TOWELS

Centerfeed Hand Towels

- Offers one-at-a-time service, and reduces waste
- High capacity, reduces labor and refills
- Few, or no moving parts, nothing to jam or break
- High absorbency, means less towels used
- Touch only dispensing towel reduces cross contamination
- Made from 100% recycled fiber
- Provides environmental benefits
- 600 towels per roll



P/N 28237

Centerfeed Dispenser

- Simplify and complement any environment, providing a clean, hygienic appearance
- Our new design ensures easy and intuitive maintenance, refilling and use
- High capacity cabinets are ideal for high traffic environments
- No cross contamination from levers or cranks
- The portion control feature dispenses one towel every time
- Cabinets are simple and reliable offering low maintenance costs

Applications

- Offices
- Plumbing Sites
- Kitchens
- Construction Sites
- Auto Shops
- Marinas
- Printing & Painting Areas
- Work Benches
- Break Rooms
- Manufacturing
- Maintenance Areas

P/N 1788



DESCRIPTION	PART
Hand Towels (600 towels per roll)	A 28237
Centerfeed Dispenser	A 1788

TOWELS IN A TUB

Chromate Advanced Shop Wipes with Bucket Dispenser

- Removable lid for easy on-off quick access.
- Pop top is resealable, angled and connected to water channels for maximum protection.
- Handle designed for easy portability and added convenience.
- Dispensing disk designed for single towel dispensing to reduce pilferage and lower cost-in-use.
- Plastic container is durable to protect against dry or wet chemicals.
- Stackable packaging design allows for more efficient packing and storage.

- Sheet Size: 9.9" x 13.1"
- Tub Size: 10" x 8.5" x 9"
- 200 Wipes

Chromate Advanced Shop Wipes Refill

- Best all purpose with cloth like softness
- Absorbs large spills and leaks
- Janitorial maintenance wiping
- Patient hygiene
- Line wiping and cleaning
- Absorbs oil and water
- Works on grease and grime
- Industrial cleaning and maintenance
- Can be used on hands and face
- 200 Wipes



DESCRIPTION	PART
Towels In A Tub with Dispenser	A 28216
Towels In A Tub – Refill	A 28217

ANTI-FATIGUE MAT

ALLEVIATES STRESS TO THE BACK AND LEGS

Anti-fatigue mats alleviate stress to the back and legs where people have to continually stand or walk, which in turn increases worker productivity. The non-slip surface means that the mat is ideal for use in wet or dry conditions to reduce slip hazards. The implementation of ergonomic concepts offers tremendous value to any company, and can be realized with the creation of comfortable, healthy and safe work environments. We know that standing workers are less fatigued while working, and feel less discomfort at the end of the day, if they stand on anti-fatigue mats. This has been proven time and time again.

- Outstanding Anti-fatigue qualities
- UV Stable
- Solid Nitrile Rubber top surface for excellent chemical resistance
- 100% Nitrile Rubber border remains flexible for the life of the mat and will not crack or curl.
- Textured Nitrile Rubber surface for superior slip resistance
- Welding Safe
- Closed-cell Nitrile/PVC cushion backing provides long lasting comfort
- Closed-cell cushion backing is permanently molded to the Nitrile Rubber surface, providing a comfortable long lasting mat.
- Thicknesses: 5/8"
- Available in black
- Certified slip-resistant by the National Floor Safety Institute.
- Recommended for use in work stations, assembly lines, shipping lines and other areas where workers stand for extended periods.



DESCRIPTION	PART
Anti-Fatigue Mat, 3' x 5'	A 28229

TOE WARMERS

KEEPS YOU WARM IN THE COLDEST WEATHER

- Adhesive Toe Warmers provide up to 5 hours of heat
- Warmers are activated when the plastic outer wrap is removed, and the inner cloth pouch is exposed to the air
- Perfect for keeping extremities warm while working outdoors in cold weather
- After use, the biodegradable cloth pouch may be simply thrown away



DESCRIPTION	PART
Toe Warmers (48 pair of Toe Warmers per box)	66384

MINI HAND WARMERS

STAY WARM AND COMBAT THE COLD

- Simply tear open the package and wait 10 minutes for them to heat up fully
- A simple, yet effective technology
- Combines several natural elements such as carbon, iron powder and vermiculite to generate an exothermic reaction
- Environmentally safe (non-toxic)
- Mini Hand Warmers deliver up to 8 hours of air activated heat and relief from the cold
- Warmers maintain a minimum temp of 104°F / average temp of 135°F / maximum temp of 156°F
- Heating can be suspended at any time by resealing the inserts in an airtight container or plastic bag



APPLICATIONS

- Industrial Safety • Construction • Emergency Services • Military • Rail Yards • Outdoor Maintenance • Outdoor Recreation • Motor Biking

**** IDEAL SIZE FOR USE WITH WINTER WATERPROOF GLOVES, P/Ns 59203 & 59204 ****

DESCRIPTION	PART
Mini Hand Warmers (1 Pair)	A 59205

ROUGH SERVICE LIGHT BULBS

Lasts longer under adverse operating conditions – 2000 to 4000 hours.
Up to 4X longer than the average life of most rough service bulbs.

STANDARD		
<ul style="list-style-type: none"> • RESISTS SHOCK AND VIBRATION • BRASS BASE 		
		
50 WATTS	75 WATTS	100 WATTS
F 28952	F 28950	F 28951

TUFF SKIN COATED		
<ul style="list-style-type: none"> • PROVIDES SAFETY FROM GLASS CUTS, ELECTRIC SHOCK AND BURNS WHEN BULBS ARE BROKEN • RESISTS THERMAL SHOCKS, PRECIPITATION, SCRATCHES AND MOLTEN SPLATTER • NO FRAGMENTATION OF GLASS IF ACCIDENTALLY BROKEN 		
		
60 WATTS	75 WATTS	100 WATTS
F 28953	F 28954	F 28955

WOBBLELIGHTS

36" PORTABLE JOBSITE LIGHTING - WOBBLELIGHT



Features

- Patented counter-weighted self-righting design!
- Floating shock system protects bulb from impact
- Low heat output, no hot surfaces
- High-impact thermoplastic housing and lens
- 400 watt Metal Halide Work Light
- Lumens: 40,000
- 360° lighting – Adjustable to 180° with optional reflector
- Plugs into 120V AC supply
- Convenience receptacle for connecting units in series

Applications

- Ideal for applications requiring temporary high-output lighting

Replacement/Optional Parts

- Bulb "400 watt" P/N 66346
- 180° reflector P/N 66347
- Body back panel P/N 66335
- Body front panel P/N 66336
- Dome cap P/N 66337
- Dome and cap P/N 66338



P/N 66345

27

27" PORTABLE JOBSITE LIGHTING - WOBBLELIGHT JR.



Features

- Patented counter-weighted self-righting design!
- Floating shock system protects bulb from impact
- Energy efficient, 85 watt, compact fluorescent bulb
- Instant-on technology
- Lumens: 5,000
- Low heat output, no hot surfaces
- High-impact thermoplastic housing and lens
- 360° lighting – Adjustable to 180° with optional reflector
- Integrated 5-foot power cord

Applications

- Ideal for applications requiring temporary energy efficient lighting.

Replacement/Optional Parts

- CFL bulb, 85 watt P/N 66343
- 180° reflector P/N 66342



P/N 66344

ADVANCED AREA LIGHTING SYSTEM

MAINTENANCE FREE LED ARRAY WITH LIFE EXPECTANCY OF OVER 50,000 HOURS

The Advanced Area Lighting System is bringing several dynamic products to the market, offering up to 56 hours of bright LED light.*

The product range starts with the compact single head beam (P/N 66301) that fits easily into confined spaces and extends to the four head beam (P/N 66307) which is capable of turning night into day. All units employ a silent, rechargeable sealed battery freeing you to work anywhere on or off the grid, no generator necessary.

* Stated runtimes based on low power setting and consecutive head activation. High power and simultaneous head use will lower total runtime.

Each product is designed with LED technology to provide a better quality of light, high reliability and low energy consumption.

The result is an energy efficient lighting solution with low long-term operating and maintenance costs.

MODEL P/N	LIGHT HEADS	RUNTIME* (PER HEAD/CONSECUTIVE)
66301	1	15
66302	1	15
66303	1	15
66304	1	10
66305	1	6
66306	2	14/28
66307	4	14/56
66308	3	N/A

PRODUCT HIGHLIGHTS



All contents stow inside a Pelican Protector Case*



Direct light where it is needed with fully articulating heads



Low battery warning system and waterproof activation switch.



3 mode waterproof switch with battery charge indicator



GREEN
60 – 100% capacity



AMBER
20 – 60% capacity



RED
0 – 20% capacity

SPECIFICATIONS

Description	Wide Beam Lighting System	Stealth Beam Lighting System	Spot Beam Lighting System	Safety Beam Lighting System	Tripod 7' Remote Area Light	Dual Portable Floodlight Station	Quad Portable Floodlight Station	Shelter Lighting System
Model P/N	66301 66301YLW	66302	66303	66304 66304GRN	66305 66305YLW	66306 66306YLW	66307 66307YLW	66308*
Light Source	High Flux LEDs	Infrared 940nm	High Flux LEDs	High Flux LEDs	LED	High flux LEDs	High flux LEDs	High Flux LEDs
Lamp Heads	1	1	1	1	1	2	4	3
No. of LEDs	24	24	24	18	10	24 (per head)	24 (per head)	24 white / 12 red (per head)
Beam Spread	90°	N/A	10°	90°	120°	90°	90°	210° Diffused
Batteries	12v Rechargeable, Sealed	12v Rechargeable, Sealed	12v Rechargeable, Sealed	NIMH	NIMH	12v Rechargeable, Sealed	12v Rechargeable, Sealed	N/A
Tested Lumen Value	1000 (Low) 2000 (High)	N/A	1000 (Low) 2000 (High)	750 (Low) 1500 (High)	1200 (Low) 2400 (High)	2000 (Low) 4000 (High)	4000 (Low) 8000 (High)	1200 (red) 6000 (white)
Battery Burn Time	15 hrs. (Low) 8 hrs. (High)	15 hrs. (Low) 8 hrs. (High)	15 hrs. (Low) 8 hrs. (High)	10 hrs. (Low) 5 hrs. (High)	6 hrs. (Low) 3 hrs. (High)	14 hrs. (Low) 7 hrs. (High)	14 hrs. (Low) 7 hrs. (High) per head	N/A
Dimensions	7.9" x 15.8" x 9.1" (20 x 40 x 23 cm)	7.9" x 15.8" x 9.1" (20 x 40 x 23 cm)	7.9" x 15.8" x 9.1" (20 x 40 x 23 cm)	7.9" x 15.8" x 9.1" (20 x 40 x 23 cm)	7.9" x 37.4" (20 x 95 cm)	13.8" x 22" x 9" (35.1 x 55.9 x 22.9 cm)	19.6" x 24.8" x 11.9" (49.7 x 63 x 30.3 cm)	16.3" x 4.1" (cylindrical) (41.4 x 10.4 cm cylindrical)
Mast Extended Height	32.3" (82 cm)	32.3" (82 cm)	32.3" (82 cm)	32.3" (82 cm)	86.3" (219 cm)	70.9" (180 cm)	72.9" (185 cm)	N/A
Weight	22.7 lbs. (10.3 kg)	22.1 lbs. (10 kg)	22.05 lbs. (10 kg)	17.6 lbs. (7.98 kg)	16.1 lbs. (7.3 kg)	50.7 lbs. (23 kg)	88.2 lbs. (40 kg)	29.8 lbs. (13.5 kg)
Colors	Yellow, Black	Gray	Black	Orange, Green	Yellow, Black	Yellow, Black	Yellow, Black	Black
Approvals	CE	CE	CE	CI D2	CE	CE	CE	CE

* Figures calculated from LED manufacturer data.

DELIVERY: PLEASE ALLOW UP TO 10 DAYS, AFTER RECEIPT OF ORDER.

SYMBOLS: Light Emitting Diode light source Rechargeable battery

ADVANCED AREA LIGHTING SYSTEM

MAINTENANCE FREE LED ARRAY WITH LIFE EXPECTANCY OF OVER 50,000 HOURS

WIDE BEAM, STEALTH BEAM AND SPOT BEAM SYSTEM

Wide Beam Lighting System P/Ns 66301 • 66301YLW



- The perfect unit for hard to reach places and at 22 lbs., it is easily transported up stairs or ladders
- Its compact size and fully extendable mast with 360° rotating light head make tight spaces easily accessible
- Dual power outputs illuminate a second optional head making it adaptable and expandable
- Solid state high efficiency circuitry withstands rigorous industrial use day in and day out



Wide Beam - P/N 66301 - P/N 66301YLW

- Wide 90° beam
- Large area coverage



Stealth Beam Lighting System P/N 66302

- Enhances night vision optics to provide improved visibility in complete darkness

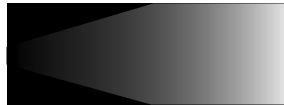

Stealth Beam - P/N 66302

- Night vision compatible infrared 7° LED beam
- Low thermal signature



Spot Beam Lighting System P/N 66303

- Produces a 10° tight beam spread that reaches hundreds of yards for effective search and rescue



Spot Beam - P/N 66303

- Focused 10° beam
- 200 yard reach



SAFETY BEAM LIGHTING SYSTEM

Safety Beam Lighting System P/Ns 66304 • 66304GRN



- Battery powered safety approved LED remote area light
- Class I Division 2 approved
- Fills the demanding requirements of professionals working in hazardous locations
- Lightweight advanced battery technology
- Ultra-portable at just 17.6 lbs.
- 90° beam spread and a rotating head are ideal for lighting large areas
- High and low beam coupled with a low battery indicator aid in managing time and output needs with accuracy



ADVANCED AREA LIGHTING SYSTEM

MAINTENANCE FREE LED ARRAY WITH LIFE EXPECTANCY OF OVER 50,000 HOURS

DUAL PORTABLE FLOODLIGHT STATION

Dual Portable Floodlight Station P/Ns 66306 • 66306YLW



- Solid-state mounted LEDs coupled with a thermally efficient light engine and a Pelican Protector Case™
- Gives the user the ultimate maintenance-free portable floodlight station
- Get the job done efficiently, safely and on time
- A rugged Pelican Protector Case™ houses all its light heads and a multi-stage universal charger for total self-contained convenience
- Also equipped with a telescopic handle and rugged wheels for ease of transport



QUAD PORTABLE FLOODLIGHT STATION

Quad Portable Floodlight Station P/Ns 66307 • 66307YLW



- Contains four heads that will illuminate 360°
- Uses solid-state mounted LEDs coupled with a thermally efficient light engine
- A rugged Pelican Protector Case™ houses all its light heads and a multi-stage universal charger for total self-contained convenience
- Equipped with a telescopic handle
- Rugged wheels for ease of transport



ADVANCED AREA LIGHTING SYSTEM

MAINTENANCE FREE LED ARRAY WITH LIFE EXPECTANCY OF OVER 50,000 HOURS

TRIPOD 7' REMOTE AREA LIGHT

Tripod 7' Remote Area Light P/Ns 66305 • 66305YLW



- The most innovative unit to date
- Fast to light up ravines, confined spaces, river banks... anyplace your apparatus can't go
- Deployed, the mast extends 7 feet high, shining light over low obstructions encountered by traditional lantern style lights
- A 120° beam spread
- Up to 2400 lumens brightness
- The entire emergency area will have the light you need for a safe and swift operation
- Maintenance free
- Uses super tough LED lamp modules and NiMH batteries
- Up to 14 hours of continuous light



Coming Soon!

- Safety approved version
- Class I Division 1 approved
- Same great features as P/N 66305 and P/N 66305YLW

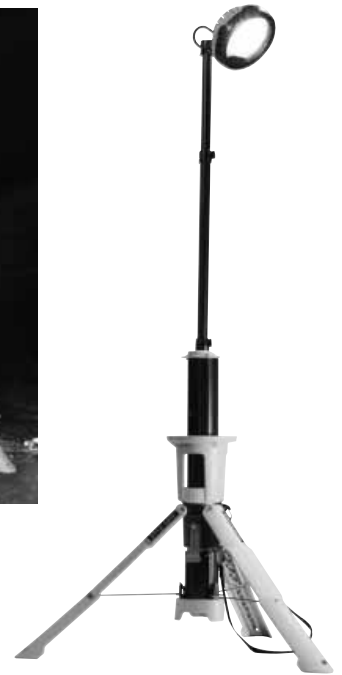

SHELTER LIGHTING SYSTEM

Shelter Lighting System P/N 66308



- The Shelter Lighting System provides soldiers with safe, secure and silent LED interior shelter lighting
- LED illuminated either red or white light
- The light output color (red or white) is selected via an inline switch
- Extremely rugged and is tested to a 3 meter concrete drop-test, offering survivability not found in fluorescent lighting
- Light heads are linked together and secured via hanging straps inside the temporary shelter/accommodation
- Each light head can be independently switched on or off
- The system is powered by the enclosed universal AC power supply

The Kit Contains:

- 3 UV stable LED light heads
- (3)12 ft. connector cables
- Hanging straps
- Power supply
- Rugged Pelican Protector Case™

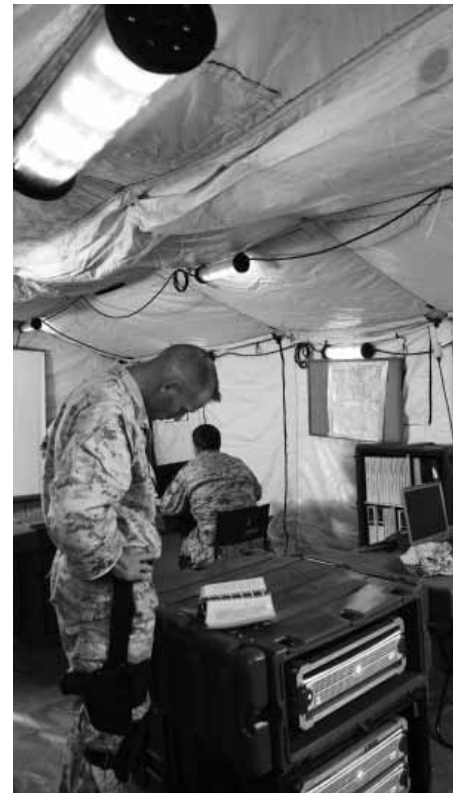

FLASHLIGHTS

DURACELL® PROCELL® FLASHLIGHT

- Convenient pop-out hanging ring
- High density polypropylene construction for durability
- Shock, corrosion and water resistant
- Ribbed non-slip grip
- Heavy duty switches and switch guard for longer life
- Non-roll barrel design
- Non-conductive hanger ring
- Integrated spare bulb holder
- Computerized parabolic reflector
- Uses 2 D-Cell alkaline batteries (not included) – Order with P/N 29201



P/N 66404

LED FLASHLIGHTS

STREAMLIGHT® TWIN-TASK™ FLASHLIGHT

- Patented led/xenon combo for super brightness and ultra-long run time
- Computer-machined – exacting tolerances for superior quality
- Anodized aluminum – for lightweight design
- Water-resistant, o-ring sealed – great for outdoor use
- Unbreakable polycarbonate lens – for durability and long life
- Adjustable focus – provides wide and narrow beam
- Micro-faceted reflector – increased brightness
- Enhanced knurled grip – ease of handling
- Lanyard included
- 100,000 hour LEDs

P/N 66400



3-Modes:

3 LEDs	6 LEDs	XENON
Run Time	Run Time	Run Time
160 Hours	100 Hours	5 Hours

LIFETIME WARRANTY!
Uses 3 "C" Alkaline Batteries (Not Included)

DESCRIPTION	PART	
STREAMLIGHT TWIN-TASK™ FLASHLIGHT	A	66400
REPLACEMENT XENON BULB	A	66400X

27

MAGNETIC LED STICK LIGHT

POWERFUL POCKET-SIZED FLOODLIGHT!

- 7 super-bright LEDs - 75 lumens output
- Powerful magnet for flush, secure attachment
- Extra strong magnet in handle provides an extra hand as well as handy pick-up tool
- Has a pocket clip that moves 0°-180° to flood in light at every angle
- Produces a floodlight effect as well as directional
- Water resistant and rugged
- Runs more than 10 hours
- Uses 3 AAA batteries (included)
- Replacement batteries (P/N 29204)

Pocket clip rotates 0°-180°.



Magnetically attach to a vertical surface!



Magnetically attach to a horizontal surface!



Magnetically attach to vertical surface!

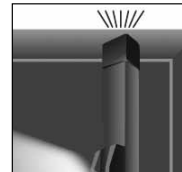

P/N 66328



LED FLASHLIGHTS

LED LIGHT (SAFETY ORANGE)

- Flashlight – Floodlight
- Bright white LEDs
- 35,000 hour life
- Small size – Light weight
- Safety orange housing
- Impact and chemical resistant
- Removable hanger-hook and magnet
- Rechargeable high quality NiMH battery
- Long run-time per charge
- Home and car chargers included



SlimLine Flashlight – P/N 66380

- Flashlight: 1 LED = 65 Lumens
- Floodlight: 60 LEDs = 120 Lumens
- Run-time: 4 hrs. flashlight, 4 hrs. floodlight
- Charge time: 4 hours
- Length: 11.5"
- Weight: 12.0 oz

P/N 66380



WATERPROOF LED FLASHLIGHT

WITH GLASS FILLED NYLON POLYMER HOUSING

- CREE® LED technology
- 50,000 + hours LED life
- Waterproof: IP-X7 Rating
- 180 Lumens
- Momentary or constant-on flashlight
- Sharp focused beam
- Aircraft-grade 6061-T6 aluminum tail-cap with type 3 hard anodized finish
- Non-slip grip

- Large textured tail-switch
- 1" Handle diameter fits most scope/flashlight mounts
- 1.25" Head diameter accepts 3rd party filters
- Impact & chemical resistant
- Removable pocket clip
- Available in Black, Yellow & Tan
- Two CR-123 lithium batteries included

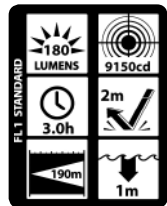

- Lumens: 180
- Run-time: 3 hours
- Beam distance: 190 meters
- Water rating: IP-X7 waterproof
- Drop rating: 2 meters

- Length: 5.5"
- Head diameter: 1.25"
- Handle diameter: 1.035"
- Weight: 4.4 oz.



P/N 66321BLA



Yellow and tan housing colors are also available. (non-stock items*).
 - P/N 66321YEL
 - P/N 66321TAN
 * Please call for delivery.

27

DESCRIPTION	PART	
Waterproof LED Flashlight – Black	A	66321BLA
Waterproof LED Flashlight – Yellow	A	66321YEL
Waterproof LED Flashlight – Tan	A	66321TAN
Replacement Lithium Batteries, Type CR-123	B	28899

LED FLASHLIGHTS

TECHNICIAN'S FLOODLIGHT

Features

- Over 300 lumens of brilliant white light with no hot spots or dark spots
- Strong, retractable hook allows you to hang it
- Dual rare-earth magnets, for fastening it to a work-space
- Removable belt clip
- Head tilts 180° and rotates 360°
- 6 AA rechargeable NiMH battery pack included, with smart recharger
- Run-time: High: 2 hours continuous, Low: 8 hours
- Battery condition indicator light
- Ergonomic light-weight, secure grip
- Includes a 12V charger and a 120V charger
- Flared base allows standing light on end
- Standard 1/4-20 threaded hole in base for tripod (not included)
- Length: 10-1/4" (26 cm)
- Weight: 1 lb (0.5 kg)

Applications

- Automotive
- Industrial
- HVAC repairmen
- IT maintenance
- Emergencies
- Power Outages

Details

Brightness: High: 300 emitter lumens
LOW: 75 emitter lumens

Color: Cool White

LED: Cree XP-G, 5 W

Material: High impact ABS, except hook, which is glass reinforced ABS

Head Adjustment: Tilt tension adjustment screw prevents head from flopping

Hook length: 3" (7.5 cm) when extended, retracts into body of floodlight

Hook diameter: 1" (2.5 cm)

Magnets: 2 co-planar, nickel-plated, neodymium rare-earth magnets

Charger: Smart switching charger, 120 VAC with standard "Type A", 2 prong plug

Recharge Time: About 6 hours

THE BEST PROFESSIONAL LED WORK LIGHT!



POCKET FLOODLIGHT™

Features

- Up to 10X Brighter than ordinary penlights
- Pure Cool White LED High Performance Light
- Lightweight & Compact
- Clips easily and comfortably into any pocket
- Indestructible Aluminum T6 with Black Type II Anodized Body
- Water & Dirt Resistant
- Rugged tailcap switch – rated at 100,000 cycles



P/N 66341

Applications

- Designed for all technicians in a demanding shop
- For use in manufacturing or maintenance environments

Details

- **Brightness:** 120 lumens
- **Forward Current:** 400 mA
- **Battery Voltage:** Between 3.3 and 4.8 volts
- **Batteries:** 3 AAAA alkaline, *included*
- **Run-Time:** 2 hours to half brightness / 4 hours light w/ typical intermittent use
- **Reflector:** Custom design w/ bright center spot.
Orange peel (OP) surface for an even beam.
- **Switch Tailcap:** Click ON / Click OFF. Rubber cap seals out dirt and grit.
- **Water Resistant:** Threaded joints have rubber O-ring seals. Sealed tailcap switch.
- **Head Diameter:** 9/16" (14 mm)
- **Body Diameter:** 7/16" (10 mm)
- **Body length:** 6" (15 cm)



AAAA Energizer Batteries (Pkg. 6)
P/N 29207

LED FLASHLIGHTS

RED LED POCKET FLOODLIGHT™

Features

- Up to 10X brighter than ordinary "Red" LED penlights
- LED high performance light
- Lightweight and compact
- Clips easily and comfortably into any pocket
- T6 Aluminum with Red Type II Anodized Body
- Water and dirt resistant
- Rugged tailcap switch – rated at 100,000 cycles
- Energizer batteries included



P/N 66333

Applications

- Preserves night vision of individuals
- Reading flight plans
- Security
- Reading equipment in the dark
- Aviators
- Doctors/Nurses monitoring patients
- Astronomers
- Military/Police operating equipment
- Emergency Service Personnel
- Photographers
- Ushers

Details

- BRIGHTNESS:** 46 lumens
- LED, WAVELENGTH:** Cree Xp-C, Red 620-630 nm
- FORWARD CURRENT:** 350 mA
- BATTERY VOLTAGE:** Between 3.3 and 4.8 volts
- BATTERIES:** 3 AAAA alkaline (included)
- RUN-TIME:** 2 hours to half brightness / 4 hours light with typical intermittent use
- REFLECTOR:** Custom design with bright center spot. Orange peel (OP) surface for a huge floodlight beam.
- SWITCH TAILCAP:** Click ON / click OFF, plus half-press momentary on. Rubber cap seals out dirt & grit.
- WATER RESISTANT:** Threaded joints have rubber O-ring seals. Tailcap switch is sealed with a rubber cap.
- HEAD DIAMETER:** 9/16" (14 mm)
- BODY DIAMETER:** 7/16" (10 mm)
- BODY LENGTH:** 6" (15 cm)

AAAA Energizer Batteries (Pkg. 6)
P/N 29207



PROFESSIONAL UV LED INSPECTION FLOODLIGHT™

Features

- Up to 20X brighter than ordinary UV penlights
- High performance UV LED light
- Lightweight and compact
- Clips easily and comfortably into any pocket
- T6 Aluminum with Violet Type II Anodized Body
- Water and dirt resistant
- Rugged tailcap switch – rated at 100,000 cycles
- Energizer batteries included



P/N 66334

Applications

- A/C refrigerant dye leak detection
- Hairline crack detection/Quality control
- Fluorescent hand stamp verification
- Dog, cat & rodent urine stain detection
- Restroom cleanliness inspection
- Document and lab analysis
- Crime scene investigation
- Paint authentication
- Currency verification
- Bacteria detection
- Gem inspection
- UV curing

Details

- BRIGHTNESS:** 120 mW emitter radiant flux
- LED, WAVELENGTH:** UltraViolet (UVA) 400-405 nm
- FORWARD CURRENT:** 350 mA
- BATTERY VOLTAGE:** Between 3.3 and 4.8 volts
- BATTERIES:** 3 AAAA alkaline (included)
- RUN-TIME:** 2 hours to half brightness / 4 hours light with typical intermittent use
- REFLECTOR:** Custom design with bright center spot. Orange peel (OP) surface for a huge floodlight beam.
- SWITCH TAILCAP:** Click ON / click OFF, plus half-press momentary on. Rubber cap seals out dirt & grit.
- WATER RESISTANT:** Threaded joints have rubber O-ring seals. Tailcap switch is sealed with a rubber cap.
- HEAD DIAMETER:** 9/16" (14 mm)
- BODY DIAMETER:** 7/16" (10 mm)
- BODY LENGTH:** 6" (15 cm)

AAAA Energizer Batteries (Pkg. 6)
P/N 29207



CAUTION: Wear 100% UVA blocking safety glasses when using. Do not shine the light in anyone's eyes.

LED FLASHLIGHTS

INTRINSICALLY SAFE LED PENLIGHTS

- 30 or 50 Lumens/Class I, II, III, Division I, Groups A-G
- CREE® LED technology – 50,000+ hours LED life
- 30 or 50 Lumens
- 13.75/18 hours run-time
- Ultra-compact and super slim
- Powerful light output designed to illuminate very tight spaces
- Single tail-cap switch provides momentary or constant-on functionality
- Sharp focused beam for distance illumination (50/40 meters)
- Waterproof: IP-X7 Rating
- Engineered polymer housing
- Impact & chemical resistant
- Built-in pocket/belt clip



Safety Rating

cETLus Listed Intrinsically Safe for use in Class I II III Div 1
SECURITE INTRINSEQUE Groups A,B,C,D,E,F & G Hazardous Locations



Specifications – P/N 66316

- Lumens: 50
- Run-time: 13.75 hrs
- Beam distance: 50 meters
- Water rating: IP-X7 waterproof
- Drop rating: 2 meters
- Length: 6.8"
- Diameters: 0.6" head / 0.5" handle
- Weight: 1.5 oz
- Power: 3 AAAA batteries (P/N 29207) included

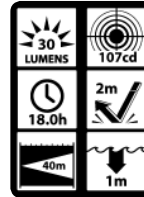
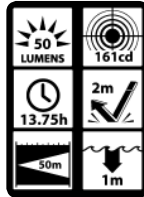

Specifications – P/N 66317*

- Lumens: 30
- Run-time: 18 hrs
- Beam distance: 40 meters
- Water rating: IP-X7 waterproof
- Drop rating: 2 meters
- Length: 5.8"
- Diameters: 0.9" head / 0.7" handle
- Weight: 1.9 oz
- Power: 2 AAA batteries (P/N 29204) included

*Non-stock item, please call for delivery.

INTRINSICALLY SAFE LED HEADLAMPS

- Dual-Function/Class I, II, III, Division I, Groups A-G
- Multi-position tilt head design with elastic head strap (with non-slip lining) and a heavy-duty rubber head strap for use on a hard hat
- Selectable high or low brightness spotlight operation
- CREE® LED technology – 50,000+ hours LED life
- High-brightness spotlight – 115/60 Lumens Low-brightness spotlight – 65/40 Lumens
- Focused spotlight beam for distance illumination (92/80 meters)
- Waterproof: IP-X7 Rating
- Engineered polymer housing
- Single switch located on top of light
- Impact & chemical resistant
- 3 AAA premium batteries (included), reorder using P/N 29204



High/Low brightness
spotlight switch

Spotlight



Safety Rating

cETLus Listed Intrinsically Safe for use in Class I II III Div 1 SECURITE
INTRINSEQUE Groups A,B,C,D,E,F & G Hazardous Locations

-20C ≤ Tamb ≤ +40C

• Ex ia IIC T3 Ga Class 1 Zone 0

• AEx ia IIC T3 Ga, Zone 20

• AEx ia IIIC T 165C Da



Specifications – P/N 66318

- Spotlight Lumens: High - 115 / Low - 65
- Run-time: High - 4.5 hrs / Low - 13 hrs
- Beam distance: 92 meters
- Water rating: IP-X7 waterproof
- Drop rating: 2 meters
- Dim: 2.4" width x 1.9" height x 1.8" depth
- Weight: 3.5 oz

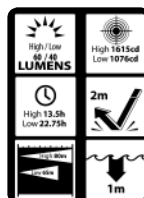
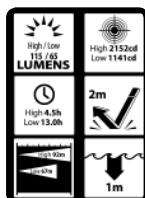

Specifications – P/N 66319*

- Spotlight Lumens: High - 60 / Low - 40
- Run-time: High - 13.5 hrs / Low - 22.75 hrs
- Beam distance: 80 meters
- Water rating: IP-X7 waterproof
- Drop rating: 2 meters
- Dim: 2.4" width x 1.9" height x 1.8" depth
- Weight: 3.5 oz

*Non-stock item, please call for delivery.

LED FLASHLIGHTS

INTRINSICALLY SAFE LED HEADLAMPS

- Designed for hazardous workplace environments
- Safe to use in potentially explosive atmospheres
- Night vision red floodlight or high contrast green floodlight
- Spotlight • Two level white floodlight • Colored floodlight
- Spotlight CREE® LED technology - 50,000 hour life
- White / red / green floodlight LEDs - 35,000 hour life
- Full or half power white floodlight for extended run-time
- Waterproof IP-X7
- Impact and chemical resistant
- Two switch light control
- Behind the head battery pack for comfort and balance
- Adjustable ratchet tilt headlamp
- Width: 3.3" • Height: 3.3" • Depth: 3.5" • Weight: 9.5 oz.
- Rubber hardhat strap included
- 3 premium alkaline AA batteries – Reorder with P/N 29203

Safety Rating

- cETLus Listed Intrinsicly Safe for use in Class I II III Div 1 SECURITE INTRINSEQUE
- Groups A,B,C,D,E,F & G Hazardous Locations
- -20C ≤ Tamb ≤ +40C • Ex ia IIC T3 Ga Class 1 Zone 0 AEx ia IIC T3 Ga, Zone 20 • AEx ia IIIC T 165C Da



P/N 66326

P/N 66327

Specifications - P/N 66326

- Spotlight: 130 lumens
- Floodlight: 100 lumens - full power, 25 half-power
- Dual-Light: 190 Lumens
- Green floodlight: 21 lumens
- Run-time hours:
 - Spotlight: 14
 - Floodlight at full power: 12.5
 - Floodlight at half-power: 70
 - Dual-light: 6
 - Green floodlight: 37

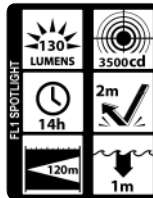

Specifications - P/N 66327

- Spotlight: 100 lumens
- Floodlight: 90 lumens - full power, 20 half-power
- Dual-Light: 175 Lumens
- Red floodlight: 18 lumens
- Run-time hours:
 - Spotlight: 18
 - Floodlight at full power: 13.5
 - Floodlight at half-power: 75
 - Dual-light: 6.5
 - Red floodlight: 37

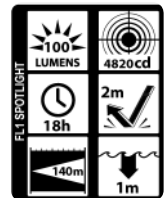

INTRINSICALLY SAFE LED DUAL-LIGHT

Designed for hazardous workplace environments and is safe to use in potentially explosive atmospheres.



CLASS I DIV 1 GRPS A-D T3 CLASS II & III GRPS E-G T13SC CLASS I ZONE 0 AEx ia IIC T3 Ga CLASS I ZONE 0 Ex ia IIC T3 Ga Ex ia I Ma Ex ia IIC T3 Ga Ex ia I G Ex ia IIC T3 Ga	Ex ia I Ma Ex ia IIC T3 Ga Inherlek IIS 13 ATEX27B37 IECEx ETL 13.0026X -20°C ≤ Tamb ≤ +40°C 1.5V/Cell AA Alkaline CE	Conforms to: ANSI/UL STD 913, ANSI/UL 60079-0, ANSI/UL 60079-11 Certified to: CAN/CSA STD C22.2 NO 137 CAN/CSA STD C22.2 NO 60079-0 CAN/CSA STD C22.2 NO 60079-11 CSA STD C22.2 NO 25
APPROVAL No. 20-A130001-0 TESTED FOR INTRINSIC SAFETY IN METHANE-AIR MIXTURES ONLY	WARNINGS: 1) MSDS approved for use with three AA Duracell Type PC1500, Energizer Type BHR, and Energizer Type LFT batteries only. 2) Replace the batteries to fresh air only and replace all batteries at the same time. Do not enter batteries from different manufacturers or of different types. 3) Energizer Lithium (Type LRT) batteries are to be replaced by a qualified technician only. 4) The brand "NIGHTSTICK" and logo shall not be copied or used where permission is required.	

- Dual-Light Innovation®
- 120 Lumen CREE® LED
- Sharp Focused Flashlight
- Broad Beam Floodlight
- 50,000 hour LED life
- Separate switches for flashlight & floodlight
- Momentary or constant-on

- Non-slip grip textured push-buttons
- Rugged hi-visibility green polymer housing
- Impact and chemical resistant
- Built-in pocket clip and lanyard
- Rating: XP-67
- Length: 7.0 in (178 mm)
- Limited lifetime warranty

ANSI Performance

- Flashlight: 120 Lumens
- Floodlight: 120 Lumens
- Dual-Light: 240 Lumens
- Flashlight beam distance: 170 m
- Run-time: 17.5 hours Flashlight/Floodlight and 4.5 hours Dual-light

Note: Order batteries with P/N 29203 (Duracell PC1500, MSHA approved batteries). See instruction manual for details. 3 AA alkaline batteries are not included.



LED FLASHLIGHTS

DUAL LIGHT W/ DUAL MAGNETS

130 Flashlight Lumens / 110 Floodlight Lumens

- Flashlight – Floodlight – Dual-light
- CREE® LED technology
- Flashlight beam distance, 181 meters
- 50,000 + hours LED life
- Momentary or constant-on flashlight
- Sharp focused beam for distance illumination
- Unfocused wide-beam floodlight for close-up illumination
- Dual-light (flashlight & floodlight at same time) for maximum versatility
- Powerful integrated magnets built into the base and clip for multiple hands-free options
- Engineered polymer housing, red or black
- Non-slip grip
- Dual body switches
- Waterproof, IP-X7 rating
- Impact and chemical resistant
- Built-in pocket/belt clip
- Includes removable lanyard
- 3 AA premium batteries included

Specifications

- Lumens:
 - Flashlight: 130 lumens
 - Floodlight: 110 lumens
 - Dual-light: 235 lumens
- Run-time:
 - Flashlight: 9.5 hrs
 - Floodlight: 10.5 hrs
 - Dual-light: 5 hrs
- Beam distance: 181 meters (594 ft)
- Water rating: IP-X7 waterproof
- Drop rating: 2 meters
- Length: 7"
- Head diameter: 1.8"
- Handle diameter: 1" x 1.3"
- Weight: 6.4 oz

Included Items

- Light with integrated magnets and built-in pocket/belt clip
- Removable lanyard
- 3 AA premium batteries

Replacement Batteries

- Duracell® Procell® AA alkaline batteries
- Pkg: 8
- P/N 29203

Flashlight



Floodlight



Dual-Light



P/N 66310
RED



P/N 66312B*
BLUE TRAFFIC
CONE



P/N 66311*
BLACK

*Non-stock item. Please call for delivery.



SAFETY LED LIGHTS - HEADLAMP - WATERPROOF

- Spotlight – Floodlight – Dual-light
- Water proof IP-X7
- Small in size, big in light output
- Perfect hands-free lighting solution
- Wear on head or mount on hard-hat
- Premium super bright white LEDs
- Single LED Deep Reflector Spotlight with CREE® LED Technology
- 12 LED Floodlight
- Spotlight - 50,000 hour life
- Floodlight - 35,000 hour life
- Impact & chemical resistant
- Single switch light control
- Adjustable ratchet tilt head lamp
- Non-slip elastic band
- 3 AAA batteries included



Features/Specifications

- **Spotlight:** 55 Lumens
- **Floodlight:** 40 Lumens
- **Dual-light:** 80 lumens
- **Run-time:**
 - Spotlight: 6 hours
 - Floodlight: 8 hours
 - Dual-light: 5 hours
- **Width:** 2.44"
- **Height:** 1.75"
- **Depth:** 1.88"
- **Weight:** 3.7 oz.

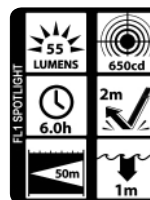

P/N 66329

LED FLASHLIGHTS

SAFETY LED LIGHTS - MULTI-FUNCTION HEADLAMP

Dual Brightness Spotlight/Floodlight & Dual-light

- CREE® LED technology – 50,000+ hours LED life
- Top mounted dual switches provide: High/low-brightness spotlight & High/low-brightness floodlight
- Dual-light (spotlight & white floodlight mode at same time) for maximum versatility
- Spotlight: 100/60 Lumens / Floodlight: 90/50 Lumens / Dual-light: 115 Lumens
- Multi-position adjustable ratchet tilt head design with non-slip elastic head strap
- Focused spotlight beam for distance illumination
- Unfocused wide-beam floodlight for close-up illumination
- Engineered polymer housing
- Waterproof: XP-X7 Rating
- Impact and chemical resistant
- Powered by 3 AAA batteries, included (reorder with P/N 29204)

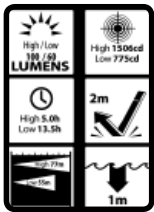
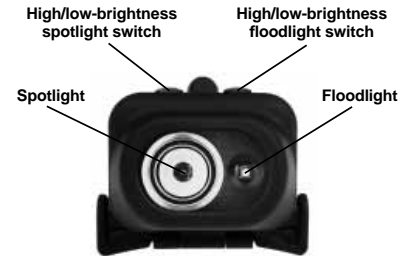

Features/Specifications

- **Lumens:**
 - High spotlight-100 / Low spotlight-60
 - High floodlight-90 / Low floodlight-50
 - Dual-light-115
- **Run-time:**
 - High spotlight-5 hrs / Low spotlight-13.5 hrs,
 - High floodlight-4.25 hrs / Low floodlight-13.75 hrs
 - Dual-light-3.5 hrs

- **Beam distance:** 77 meters
- **Water rating:** IP-X7
- **Drop rating:** 2 meters
- **Width:** 2.6in
- **Height:** 2.1in
- **Depth:** 1.8in
- **Weight:** 3.3oz

SAFETY LED LIGHTS - MULTI-FUNCTION HEADLAMP

Dual Brightness Spotlight, White/Red/Green Floodlight & Dual-light

- CREE® LED technology – 50,000+ hours LED life
- Top mounted dual switches provide: High/low-brightness spotlight and White/red/green floodlight
- Dual-light (spotlight & white floodlight mode at same time) for maximum versatility
- Colored floodlight for night-vision preservation
- Spotlight – 150/80 Lumens / White Floodlight – 100 Lumens / Red Floodlight – 9 Lumens / Green Floodlight – 18 Lumens / Dual-light – 180 Lumens
- Multi-position adjustable ratchet tilt head design with non-slip elastic head strap
- Focused spotlight beam for distance illumination
- Unfocused wide-beam floodlight for close-up illumination
- Engineered polymer housing
- Waterproof: XP-X7 Rating
- Impact and chemical resistant
- Powered by 3 AAA batteries, included (reorder with P/N 29204)

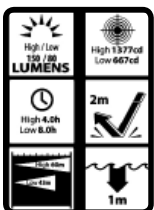
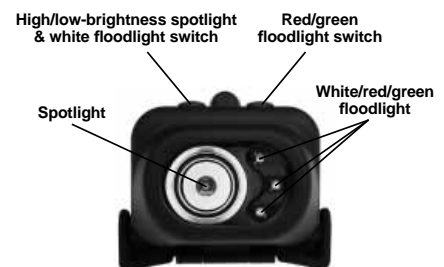

Features/Specifications

- **Lumens:**
 - High spotlight-150 / Low spotlight-80
 - White floodlight-100
 - Red floodlight-9
 - Green floodlight-18
 - Dual-light-180
- **Run-time:**
 - High spotlight-4 hrs / Low spotlight-8 hrs,
 - White floodlight-4 hrs / Red floodlight-25 hrs
 - Green floodlight-22.5 hrs / Dual-light-3 hrs

- **Beam distance:** 60 meters
- **Water rating:** IP-X7
- **Drop rating:** 2 meters
- **Width:** 2.6in
- **Height:** 2.1in
- **Depth:** 1.8in
- **Weight:** 3.3oz

LED FLASHLIGHTS

66 LED RECHARGEABLE MAGNETIC WORK LIGHT

Spotlight



Floodlight



Features/Specifications

- Spotlight: 32 Lumens
- Floodlight: 230 Lumens
- Run-time: Spotlight 18 hours / Floodlight 3 hours
- Dual integrated magnets & hook
- Single rocker switch
- Water rating: IP-X4 water resistant
- Length: 14.25" (without hook)
- Weight: 16 oz. with battery

- Dual Function / Spotlight – Floodlight
- 35,000 hour LED life
- 60 LED Floodlight / 6 LED Spotlight
- Bright white LEDs
- Impact and chemical resistant housing
- Rechargeable NiMH battery pack
- 8 hour charge time
- AC & DC adapters included
- Will stand upright on flat surface
- Dual position magnetic hook attaches to top or side
- Water resistant: IP-X4 rating

P/N 66358



Magnetic Hook
P/N 66358HOOK

RECHARGEABLE 120 LED UNDER-HOOD WORK LIGHT

- Under-hood illumination
- Interior illumination
- 120 premium LEDs
- 35,000 hour life
- Two light levels (full or half power)
- Use in the shop or roadside
- Use with or without the carrier
- Internal NiMH battery pack
- AC & DC chargers included
- Shop and car chargers included
- Chemical resistant housing
- Moisture and impact resistant
- Magnetic or hanger-hook mounting
- Spring loaded carrier extends 77"



27

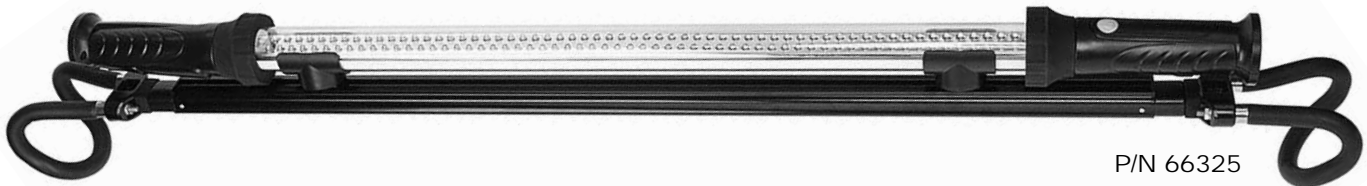

P/N 66325

Hook or Magnet Mounting Options

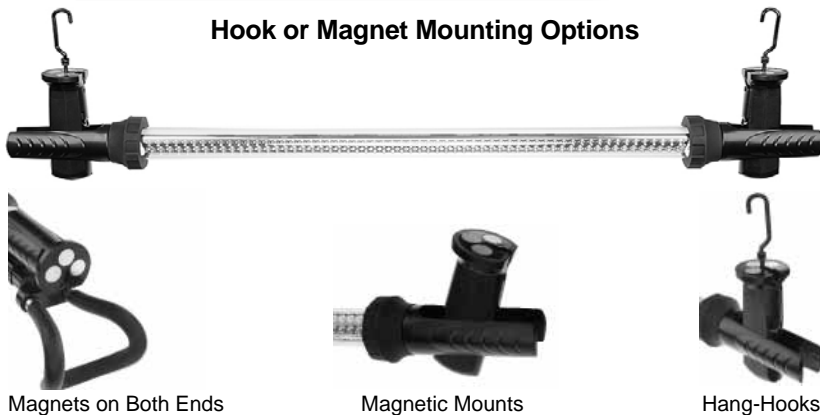

Magnets on Both Ends

Magnetic Mounts

Hang-Hooks

Specifications

- 1 Row (60 LED)
Lumens: 150
Run-time: 6.5 hours
- 2 Rows (120 LED)
Lumens: 330
Run-time: 3.5 hours
- Charge Time: 6 hours (AC or DC chargers)
- Length: 48"
- Weight: 4.9 lbs

LED FLASHLIGHTS

EXTENDABLE MAGNETIC LED FLASHLIGHT

- Metal casing
- Weight: 3.5 ounces
- Magnet at light is for powerful retrieval
- Magnet on grip acts as a third hand
- 3 super-bright LEDs
- Extends from 6.5" to 21"
- Flexible shaft to access hard-to-reach places
- A pick-up tool and a flashlight
- Uses Four LR44 1.5V batteries (included)
- Replacement batteries - 4 pack (P/N 29206)
- Utility holster with metal belt clip (P/N 70005)
- Magnetic inspection mirror (P/N 66349M)



P/N 66349

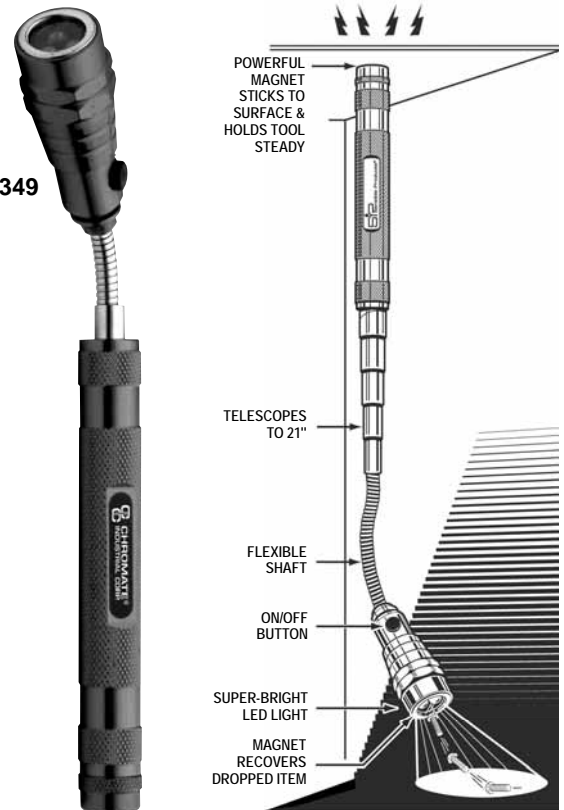

LIGHTED PICK-UP TOOLS



P/N 66324 - A SET OF 2 FLEXIBLE, LIGHTED PICK-UP TOOLS WITH DURABLE STORAGE CASE

Makes it fast and easy to find and retrieve the small object that always falls through your fingers! See and reach into awkward spaces where only the lighted pick-up tool can fit.

- The **Blue Lighted Pick-up Tool** is magnetic and works well when picking up metal objects.
- The **Red Lighted Pick-up Tool** is not magnetic and is great when a magnet would be a drawback.
- Both are flexible and made to fit into cramped spaces as well as reach around obstacles.
- Handy LED light with easy On/Off button.
- Approximately 24 inches long.
- Both tools use 3 LR-44 batteries (included). Reorder with P/N 29206 (4-pack).

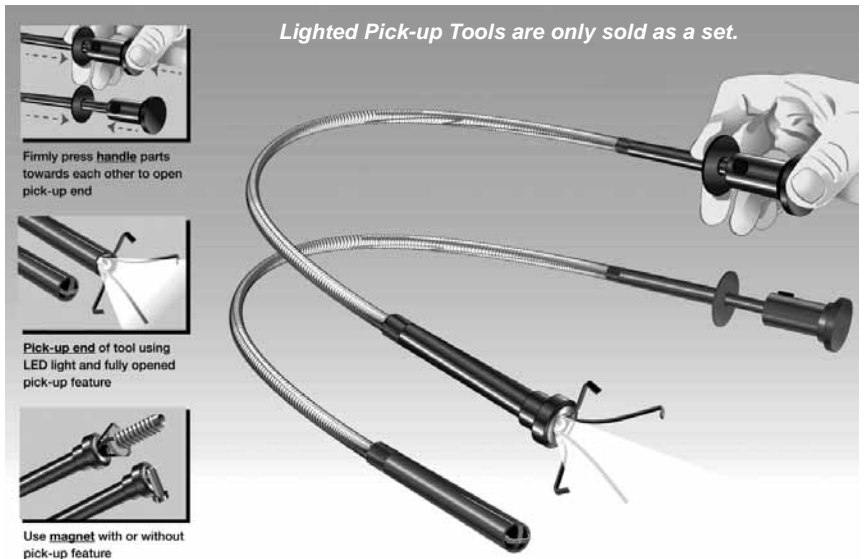

LED FLASHLIGHTS

MULTI-FUNCTION LED FLASH/FLOODLIGHT

- Flashlight – Floodlight – Dual-Light
- Single body switch
- Flashlight with CREE® LED technology
 - 50,000 + hours LED life
- Floodlight with premium LED technology
 - 35,000 + hours LED life
- Momentary or constant-on flashlight
- Sharp focused beam flashlight
- Wide-beam unfocused floodlight
- Engineered polymer housing
- Non-slip grip – Comfortable oval shape
- Soft touch finish
- Water resistant
- Impact and chemical resistant
- 2 AAA premium alkaline batteries included



- **Lumens:**
 - Flashlight - 60
 - Floodlight - 25
 - Dual-light - 50
- **Run-time:**
 - Flashlight - 4 hrs
 - Floodlight - 4 hrs
 - Dual-light - 3 hrs
- **Beam distance:**
 - 50 meters
- **Water rating:** IP-X6
 - water resistant
- **Drop rating:** 2 meters
- **Length:** 4.7"
- **Width:** 1.1" x 0.8"
- **Weight:** 2.2 oz

P/N 66322



Metal pocket clip included

SAFETY LED LIGHTS - CLAMP LIGHT



P/N 66359

Features/Specifications

- **Spotlight:** 65 Lumens
- **Floodlight:** 24 Lumens
- **Dual-Light:** 89 Lumens
- Detachable Light with Magnetic Base
- 2 Beam Flashlight
- Run-time: Up to 18 hours

- **Spotlight/Flashlight – Floodlight – Dual-light**
- **35,000 hour LED life**
- **1 Spotlight LED**
- **12 Floodlight LEDs**
- **Multi-function locking clamp**
 - Stands by itself
 - Secures to round objects and flat objects
- **Light reaches out in all directions**
 - Light swivels 360°
 - Light tilts 180° +
- **Impact & moisture resistant safety orange light housing**
- **Engineered polymer clamp base**
- **Premium AAA batteries included**



Self Standing



2 Beam Flashlight



Round Stock



Square Stock

Detachable Light with Magnetic Base



LED FLASHLIGHTS

SAFETY LED LIGHTS - HEAVY DUTY - 300/400 LUMENS



P/N 66354



- Flashlight – Floodlight – Dual-light
- Anti-roll Tri-Lobal Design
- Bright LEDs – 50,000 hour life
- Microprocessor controlled
- Impact and chemical resistant housing
- Replaceable NiMH battery pack
- Rechargeable
- 3 hour charge time
- AC & DC adapters included
- Made in the USA

Features/Specifications

- **Flashlight:** 300 Lumens
- **Floodlight:** 400 Lumens
- **Run-time:**
 - Flashlight or floodlight 9 hours
 - Flashlight strobe 24+ hours
 - Dual-light 4 hours
 - Dual-light strobe 7 hours
- Selectable flashlight or floodlight strobe
- Vehicle mount
- Moisture resistant
- Traffic Cone Accessories
 - Red P/N 66355R
 - Yellow P/N 66355Y



SAFETY LED LIGHTS - HEAVY DUTY - 160/200 LUMENS



P/N 66356



- Flashlight – Floodlight – Dual-light
- Anti-roll Tri-Lobal Design
- Bright LEDs – 50,000 hour life
- Impact and chemical resistant housing
- Replaceable NiMH battery pack
- Rechargeable
- 3 hour charge time
- AC & DC adapters included
- Made in the USA

Features/Specifications

- **Flashlight:** 160 Lumens
- **Floodlight:** 200 Lumens
- **Run-time:**
 - Flashlight 6 hours
 - Floodlight 2 hours
 - Both 2 hours
- Dual-switch control
- Tandem operation
- Auto-strobe
- Waterproof to 3 feet (IP-67)
- Traffic Cone Accessories
 - Red P/N 66357R
 - Yellow P/N 66357Y



SAFETY FLARES

FOR LONG DISTANCE ILLUMINATION

- PROVIDES LONG DISTANCE ILLUMINATION FOR SAFETY DURING EMERGENCY ROAD-SIDE SITUATIONS
- VISIBLE IN FOG, RAIN OR SNOW
- EASY TO IGNITE WITH SELF-CONTAINED STRIKER
- 20 MINUTE DURATION
- 36 FLARES IN A CASE



DESCRIPTION	PART
20 MINUTE NON-SPIKE SAFETY FLARES (Package Quantity: 36 Flares)	59080

EARLY WARNING TRIANGLE KIT

REFLECTIVE SAFETY WARNING SYSTEM

- Instant Alert for Oncoming Motorists
- Meets US Federal Motor Vehicle Safety Standard No. 125 for Warning Devices
- Weighted Base for Stability
- Kit Includes 3 Reflective Triangles

- APPLICATIONS**
- Emergency Assistance
 - Truck / Auto Accidents
 - Hazardous Conditions
 - Visually Alerts Authorities Quickly



DESCRIPTION	PART
EARLY WARNING TRIANGLE KIT	A 59082

27

GLOW STICKS

A DEPENDABLE LIGHT SOURCE THAT LASTS FOR 12 HOURS

- A DEPENDABLE LIGHT SOURCE WHENEVER AND WHEREVER YOU NEED IT, LIGHT LASTS FOR 12 HOURS
- NON-TOXIC / NON-FLAMMABLE / WEATHERPROOF
- MADE WITH CYALUME® TECHNOLOGY (10 mL FLUID)
- TO ACTIVATE REMOVE FROM FOIL WRAPPER, BEND, SNAP AND SHAKE



DESCRIPTION	PART
6" GLOW STICKS – 12 HOUR	J 59081

THREAD RESTORERS

INTERNAL THREAD RESTORERS

- QUICKLY ADJUSTABLE TO ANY THREAD DIAMETER AND PITCH WITHIN THE SIZE RANGE INDICATED ON THE TOOL
- APPLICABLE TO MOST KINDS OF THREAD – INCH, METRIC, RH OR LH, FINE OR COARSE
- A MAJOR ADVANTAGE OVER TAPS IS THE ABILITY TO ENTER BELOW THE FIRST DAMAGED GROOVES, OFTEN AT THE START OF THE THREAD – AND WORK IN AN OUTWARD DIRECTION
- THE BLADE (62 RC), GUIDED BY THE EXISTING UNDAMAGED THREAD TO REGROOVE THE DAMAGED SECTION



P/N 40136



P/N 40137



P/N 40138



P/N 40140



P/N 40135

#1
Turn knurled knobs (K) to fully retract the blade (B) into the housing (H). Insert tool into the threaded hole or bore to be repaired.

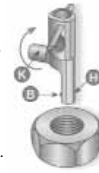

#2
Turn knurled knob (K) to extend blade (B) into a thread groove on an undamaged section and tighten by hand only.

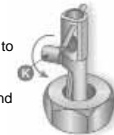

#3
Rotate tool by the cross-road, as shown, in the desired direction.



STANDARD THREAD	PIPE SIZE	PART	BLADES	PART
5/16" - 7/16" (8mm - 11mm) Thread Restorer	1/8" - 3/16"	A 40131	Replacement Blade for 40131	A 40131B
1/2" - 5/8" (12mm - 16mm) Thread Restorer	1/4" - 3/8"	A 40132	Replacement Blade for 40132	A 40132B
11/16" - 13/16" (16mm - 20mm) Thread Restorer	3/8" - 1/2"	A 40133	Replacement Blade for 40133	A 40133B
7/8" - 1-1/4" (22mm - 32mm) Thread Restorer	1/2" - 7/8"	A 40134	Replacement Blade for 40134	A 40134B
1-1/4" - 2-1/8" (32mm - 54mm) Thread Restorer	7/8" - 1-3/4"	A 40135	Replacement Blade for 40135	A 40135B
THREAD RESTORER SETS:				
1/2" - 1-1/4" (12mm - 32mm) 3-Pc Set contains 1 each: 40132, 40133 and 40134				A 40136
1/2" - 2-1/8" (12mm - 54mm) 4-Pc Set contains 1 each: 40132, 40133, 40134 and 40135				A 40137
1/4" - 3/4" External and 1/2" - 13/16" Internal 3-Pc Combo Set contains 1 each: 40141, 40132 and 40133				A 40138
5/32" - 1-1/2" External & 1/2" - 1-1/4" Internal 5-Pc Combo Set contains 1 each: 40141, 40142, 40132, 40133 & 40134				A 40140

NOTE: Item numbers in italics are non-stock items

EXTERNAL THREAD RESTORERS

- AN ESSENTIAL TOOL FOR REPAIRING THREADS ON BOLTS IN MAINTENANCE, GARAGES, PLUMBING, CONSTRUCTION, AGRICULTURE AND ENGINEERING
- ADJUSTS TO FIT ANY THREAD DIAMETER AND PITCH
- NO MEASURING OF THREAD REQUIRED
- CAN BE USED ON RIGHT OR LEFT HAND THREADS
- APPLICABLE TO ALL KINDS OF THREADS – BOTH INCH & METRIC
- TWO HARDENED STEEL BLADES (58 RC), GUIDED BY THE EXISTING THREAD, REGROOVE THE DAMAGED AREA



P/N 40143



P/N 40141



P/N 40142



- REVERSIBLE BLADES PREVENTS DAMAGE TO PIPE SURFACE
- SPECIAL APERTURE FOR EXTENSION ROD (INCLUDED) FOR GREATER TORQUE



P/N 40130

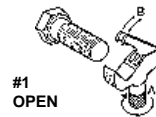

#1 OPEN

Turn handle (A) to raise blades (B). Place over bolt to be repaired.



#2 CLOSE

Turn handle (A) to lower blades into grooves of thread and tighten lightly.

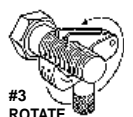

#3 ROTATE

Turn Thread Restorer in the direction of the arrow shown.

DESCRIPTION	PART	BLADES	PART
5/32" - 11/16" (4mm - 18mm) Thread Restorer	A 40141	2-Pack Blades for 40141	A 40146
11/16" - 1-1/2" (17mm - 38mm) Thread Restorer	A 40142	2-Pack Blades for 40142	A 40147
1-1/4" - 5" (32mm - 128mm) Thread Restorer	A 40143	2-Pack Blades for 40143	A 40148
5/32" - 1/2" (4mm - 13mm) Threadmate™ (Universal Thread Repair Tool)			A 40130
5/32" - 1-1/2" (4mm - 38mm) 4-Pc Combo Pack contains 1 each: 40141, 40142, 40146 and 40147			A 40144
5/32" - 5" (4mm - 128mm) 8-Pc Combo Pack contains 1 each: 40141, 40142, 40143, 40146, 40147, 40148, extension rod & cleaner			A 40145

SHEARS AND SNIPS

SPECIALIZED SNIPS

FEATURES

- Three types to choose from:
 - Cuts left and straight
 - Cuts right and straight
 - Cuts straight and wide curves
- Hot-drop forged steel blades for a sharper cutting edge and greater strength
- Cuts 18 ga Cold-Roll Steel and 23 ga Stainless Steel
- Ergonomically designed ProTouch™ Grips and long-life spring increase leverage and optimize each cut
- Multiple pivot pins that provide compound cutting action
- E-Z close latch



P/N 78052



P/N 78053



P/N 78054



APPLICATIONS

- For cutting sheet metal, vinyl, plastic, rubber and more

DESCRIPTION	SIZE OF SNIP	LENGTH OF CUT	CUTTING CAPACITY	PART
Cuts left and straight	10" (254 mm)	1-5/16" (33 mm)	Cold-Roll Steel 18 ga / Stainless Steel 23 ga	A 78052
Cuts right and straight	10" (254 mm)	1-5/16" (33 mm)	Cold-Roll Steel 18 ga / Stainless Steel 23 ga	A 78053
Cuts straight and wide curves	10" (254 mm)	1-5/16" (33 mm)	Cold-Roll Steel 18 ga / Stainless Steel 23 ga	A 78054

ALL PURPOSE SHEARS

- Compact, with a tough, strong NYGLASS® composite body
- Comfortable and ready to cut almost anything

Designed to cut: cardboard, tar paper, insulation, upholstery, leather, cords, light sheet metals, vinyls, banding straps, plastics, screen, carpet and more



DESCRIPTION	PART
All-purpose shears	A 78033

UPRIGHT SNIPS

- Patent pending 90° handle/blade design
 - Makes cutting easier by not breaking or bending the wrist
- Unique push or pull cutting motion – makes cutting easier in confined areas
- Snip can turn or rotate in hand while cutting circles
 - Reduces cutting time and increases productivity
- Creates ergonomic wrist and hand posture which improves wrist range motion And safety by elevating hands above edges and surfaces
- Unbreakable blades – hot drop-forged of molybdenum alloy steel and heat treated For exceptional strength, durability and sharpness
- Right handed snips cut left (counterclockwise) and left handed snips cut right (clockwise)



DESCRIPTION	PART
Right handed upright snips (red handle)	A 78035
Left handed upright snips (red handle)	A 78035L

CHISEL AND PUNCH SET

STRIKING TOOLS

- MANUFACTURED OF HARDENED CHROME VANADIUM STEEL FOR SUPERIOR STRENGTH AND PERFORMANCE
- CHISELS & PUNCHES ARE QUENCHED AND TEMPERED AS A WHOLE TO GUARANTEE EXCELLENT RESILIENCE TO HARD WORKING STRESS AND PROVIDES LONGER LIFE
- HARDENED STRIKING HEADS RESIST SPLINTERING AND/OR MUSHROOMING
- MEETS DIN 7255 STANDARDS

PRECAUTIONS:

- ALWAYS WEAR SAFETY GLASSES
- SELECT THE RIGHT STRIKING TOOL AND AN APPROPRIATE HAMMER SIZE FOR BEST POSSIBLE APPLICATION
- AVOID WORKING ON HARDENED MATERIAL EXCEEDING 40 HRC FOR DANGER OF BEING INJURED BY SPLINTERING
- GRIND AWAY BURRS OCCURRING ON THE STRIKING HEAD AT REGULAR INTERVALS
- ALWAYS CHECK THE CUTTING EDGE FOR WORK-WORN EDGES THAT NEED TO BE REGROUND PRIOR TO USE



DESCRIPTION	PART	DESCRIPTION	PART
1/2" x 6" FLAT COLD CHISEL	A 12051	1/8 x 4-3/4 TAPER PUNCH	A 12055
1/2" x 5" FLAT COLD CHISEL	A 12052	5/32 x 4-3/4 TAPER PUNCH	A 12056
5/32" x 5" CROSSCUT CHISEL	A 12053	CHISEL & PUNCH INDEX ONLY	A 8809
5/32 x 4-3/4 CENTER PUNCH	A 12054	6-PIECE CHISEL & PUNCH SET WITH INDEX	A 12050

DEBURRING TOOLS

STANDARD DUTY

- TAKES ALL B-SERIES BLADES
- SET INCLUDES ONE B-10 BLADE AND ONE B-20 BLADE
- HOLDER TELESCOPES FROM 1/2" TO 5"
- HANDLE HAS STORAGE COMPARTMENT FOR SPARE BLADES
- BLADE CAN BE INSERTED AT 90° FOR DEBURRING CROSS HOLES
- HANDLE HAS LIFETIME GUARANTEE

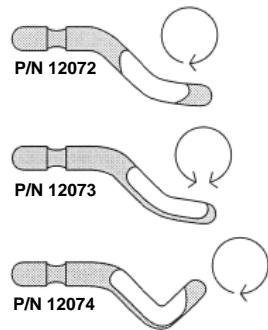

DESCRIPTION	PART
Deburring Blade B-10 (HSS for steel and aluminum)	I 12072
Deburring Blade B-20 (HSS for brass and cast iron; can rotate clockwise and counterclockwise)	I 12073
Deburring Blade B-30 (HSS; removes internal and external burrs simultaneously from holes drilled into tubing and sheet metal)	I 12074
Deburring Tool w/B-Series Blades Complete Set	A 12070

HEAVY DUTY

- TAKES ALL HEAVY DUTY E-SERIES BLADES
- SET INCLUDES ONE E-100 BLADE, ONE E-200 BLADE AND ONE E-300 BLADE
- HOLDER TELESCOPES FROM 1/2" TO 5"
- HANDLE HAS STORAGE COMPARTMENT FOR SPARE BLADES
- HANDLE HAS LIFETIME GUARANTEE

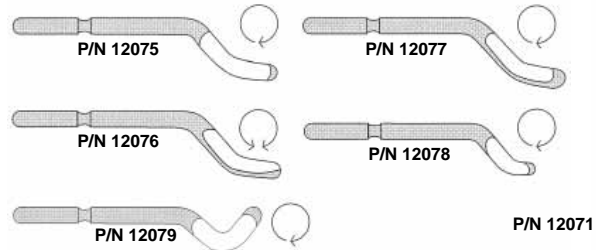

DESCRIPTION	PART
Deburring Blade Heavy Duty E-100 (Heavy Duty HSS for steel and aluminum)	I 12075
Deburring Blade Heavy Duty E-200 (Heavy Duty HSS for brass and cast iron)	I 12076
Deburring Blade Heavy Duty E-300 (Heavy Duty HSS; removes internal and external burrs simultaneously from holes drilled into tubing and sheet metal)	I 12079
Deburring Blade Heavy Duty E-350 (Heavy Duty HSS for straight edges on all materials)	I 12077
Deburring Blade Heavy Duty E-101 (Heavy Duty HSS for holes as small as 7/64" diameter in steel and aluminum)	I 12078
Deburring Tool w/E-Series Blades Complete Set	A 12071

EMERGENCY TOOL / REPAIR KIT

THE ULTIMATE EMERGENCY TOOL/REPAIR KIT

Contains 14 of the highest quality items you might need in an emergency. Including booster cables for a quick jump, and fusion seal wrap for a temporary hose repair.

- DURABLE, EASY-TO-TRANSPORT CASE MADE OF RUGGED DOUBLE-WALL CONSTRUCTION
- UNIQUE DESIGN FITS UNDER OR BEHIND SEATS
- MESH POUCH FOR GLOVES, RAGS, ETC.
- LARGE COMPARTMENT FOR JUMPER CABLES
- 9 INTERIOR POCKETS CRADLE TOOLS, FLASHLIGHT, ROAD FLARES AND MORE



DESCRIPTION	PART	DESCRIPTION	PART
EMERGENCY TOOL/REPAIR KIT BAG ONLY	A 78034	3C TWIN-TASK STREAMLIGHT (includes batteries)	A 66400
HD BOOSTER CABLES 4ga x 16"	A 28090	ERGO-KNIFE (comes with one blade)	A 66411
FIRST AID BANDAGE KIT	A 16850	RED LION E-Z POXY 200	A 74502
RED LION SUPER ADHESIVE SEALANT	A 74510	15" RUBBER STRAP WITH HOOKS	A 60386
EMERGENCY FLARES	A 59080	21" RUBBER STRAP WITH HOOKS	A 60387
8" LONG NOSE PLIERS	A 9-45103	ECONOMY SPLIT LEATHER GLOVES	A 59030
8" CRESCENT WRENCH	A 9-44603	1x 36 FUSION SEAL ELECTRICAL WRAP	A 28991
CHROMATE 4-in-1 SCREWDRIVER	A 16142	EMERGENCY REPAIR KIT – COMPLETE SET	A 61681

27

PORTABLE POCKET

HOLD MORE STUFF

- VERSATILE DESIGN CARRIES FASTENERS OR A TAPE MEASURE
- USE ALONE OR ATTACH TO A TOOL BELT FOR ADDED CAPACITY
- WIDE-OPENING POUCH HOLDS NAILS, SCREWS AND OTHER FASTENERS
- ELASTIC LOOPS HOLD PEN, PENCIL OR SCREWDRIVER



- GSA CARPENTER'S PENCIL (GSA167560)
 - Contractor's tool for measuring wooden structures
 - Includes Chromate logo, website and GSA contract information
- 6-IN-1 SCREWDRIVER (16142)
 - Heavy-duty steel with plastic handle
 - Comes complete with 2 slotted and 2 phillips tips
- CENTER POINT TAPE MEASURE (162446)
 - Patented center-finding scale
 - Standard layout marks
 - .050-gauge blade for long stand out
 - Tough ABS housing for long life
 - Heavy-duty spring for smooth retract
 - High visibility safety yellow color
 - Triple rivet hook connection
 - Made in USA



DESCRIPTION	PART	DESCRIPTION	PART
PORTABLE POCKET BAG ONLY	A 78036	CENTER POINT TAPE MEASURE	A 162446
CARPENTERS' PENCIL (GSA)	A GSA167560	BUCKET BOSS® PORTABLE POCKET - COMPLETE SET	A 61674
4-IN-1 SCREWDRIVER	A 16142		

TIRE REPAIR KIT

SEALS THE INJURY COMPLETELY THROUGH THE TIRE

- SEALS THE INJURY COMPLETELY THROUGH THE TIRE, KEEPING OUT MOISTURE AND CONTAMINATES THAT CAN CAUSE THE CORDS TO RUST AND CAUSE TIRE SEPARATION
- CONFORMS TO THE SHAPE OF THE INJURY, UNLIKE HARD-CURED REPAIRS THAT FORCE THE INJURY TO CONFORM TO THE SHAPE OF THE PLUG
- CONFORMS TO THE SIZE AND SHAPE OF THE INJURY & ELIMINATES STRESS TO THE BELTS AND PRESERVE THE TIRE BODY WHILE COMPLETELY SEALING OUT MOISTURE AND DIRT

KIT INCLUDES:

- PROFESSIONALLY ENGINEERED HEAVY DUTY HIGH IMPACT MOLDED CASE WITH INDUSTRIAL STRENGTH LATCH
- HEAVY DUTY 12 OZ CHROME T-HANDLE WITH REPLACEABLE NEEDLE
- SPIRAL DESIGNED PROBE CLEANS INJURY WITHOUT CAUSING ADDITIONAL STRESS OF THE TIRE
- HARDENED STEEL SET SCREW HOLDS NEEDLE OR PROBE IN PLACE WITHOUT STRIPING
- CHROME OPEN-EYE INSERTION NEEDLE
- HARDENED STEEL ALLEN WRENCH FOR EASY REPLACING PROBE NEEDLE OR OPEN-EYE NEEDLE
- RAZOR BLADE TO CUT OFF EXCESS REPAIR
- LARGE JAR OF INSERTION LUBE, MAKES INSERTING PROBE AND REPAIR EASY
- 40 PERMANENT REPAIRS, 4 INCHES LONG WITH CARBON BLACK ADDED TO STRENGTHEN REPAIRS AND MATCH THE COLOR OF THE TIRE
- INSTRUCTION GUIDE PERMANENTLY ADHERED TO INNER LID



DESCRIPTION	PART
TIRE REPAIR KIT	A 78028
4" REPLACEMENT STRIPS	I 78023
TIRE REPAIR LUBE	A 78024

PAINT STICKS & PAINT MARKERS

PAINT STICKS

- REAL PAINT IN STICK FORM
- WEATHER-RESISTANT, UV-RESISTANT
- IDEAL FOR LAYOUT, COLOR CODING, FABRICATION AND IDENTIFICATION
- MARKS THROUGH OIL AND WATER
- MARKS ON SMOOTH, ROUGH, RUSTY OR DIRTY SURFACES
- FOR USE ON METAL, WOOD, PLASTIC, CONCRETE, RUBBER, GLASS, CARDBOARD AND PAPER
- LEAD-FREE
- MARKING RANGE:
-50°F to 150°F
(-46°C to 66°C)



DESCRIPTION	PART
Cold Surf – White	J 28400
Cold Surf – Yellow	J 28401
Cold Surf – Red	J 28402
Cold Surf – Black	J 28403

VALVE ACTION PAINT MARKERS

- MARKS WITH REAL PAINT, DRIES IN 3 MINUTES
- NIB RELEASE PAINT AS NEEDED FOR CONTINUOUS MARKING
- MARKS ON ALL SURFACES INCLUDING METAL, WOOD, GLASS, PLASTIC, RUBBER CARDBOARD AND PAPER
- LEAD FREE, LOW HALOGENS
- DURABLE METAL BARREL
- MEETS CALIFORNIA VOC REGULATIONS
- MARKING RANGE: -50°F to 150°F (-46°C to 66°C)





DESCRIPTION	PART
Valve Action Marker – White	B 28404
Valve Action Marker – Yellow	B 28405
Valve Action Marker – Red	B 28406
Valve Action – Black	B 28407

4 in 1 MULTI-SOCKET TOOLS

INCH AND METRIC TOOLS

- Replaces the four most common nut drivers with one tough, yet compact, tool.
- Telescoping action provides 2 socket sizes at each end.

- High-torque grip has textured, non-slip surface.
- Tough, high quality industrial steel construction.
- Color-coded grip ends for easy recognition.

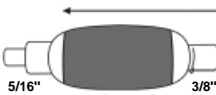
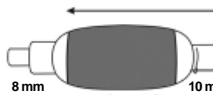
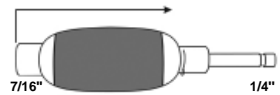
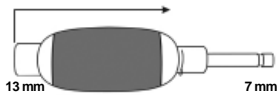
Standard Tool	P/N 2550	Metric Tool	P/N 2555
 <p>Socket Sizes - 1/4" - 3/8" - 5/16" - 7/16"</p>		 <p>Socket Sizes - 7 mm - 8 mm - 10 mm - 13 mm</p>	
 <p>5/16" 3/8" Push right For 5/16" or 3/8" Socket</p>		 <p>8 mm 10 mm Push right For 8 mm or 10 mm Socket</p>	
 <p>7/16" 1/4" Push left For 7/16" or 1/4" Socket</p>		 <p>13 mm 7 mm Push left For 13 mm or 7 mm Socket</p>	

PRY-ANGLE BAR

SMALL ENOUGH FOR A TOOLBOX

- PRY BAR HEAD ADJUSTS 5 WAYS FOR ACCESS IN DIFFICULT AREAS AND MAXIMUM LEVERAGE
- EASILY ADJUSTED AND LOCKED IN PLACE WITH SPRING-LOADED THUMB LEVER AT 180°, 155°, 130°, 105° or 80° POSITIONS
- 16" LONG – SMALL ENOUGH FOR A TOOLBOX AND LONG ENOUGH FOR SUPERIOR LEVERAGE
- RATED UP TO 350 LBS. OF TORQUE/LOAD



27

DESCRIPTION	PART
Pry-Angle Bar 16"	A 66394

LOCK-JAW PLIERS

SELF-ADJUSTING AND LOCKING



- **Chrome molybdenum steel**
For durability and rust prevention.
- **Grab thick or grab thin**
Patented locking mechanism allows the jaws to automatically adjust to any size with equal pressure. Eliminates the knob hassle.
- **Easy squeeze comfort release lever**
Stays locked until you release it.
- **Set and forget pressure control**
Dial in the amount of gripping force from slight to extreme and forget it. Regardless of the size of object you want to grab.
- **No slip texture grip**
Stays in your hands.



DESCRIPTION	PART	
6" Curved Jaw Self-Adjusting Plier	A	66387
10" Curved Jaw Self-Adjusting Plier	A	66388
7" Needle Nose Self-Adjusting Plier	A	66389
Self-Adjusting Pliers 2-Piece Set (Includes 6" and 10" Curved Jaw)	A	66387SET2
Self-Adjusting Pliers 2-Piece Set (Includes 10" Curved and 7" Needle Nose)	A	66389SET2
Self-Adjusting Pliers 3-Piece Set (Includes 6", 10" Curved Jaw and 7" Needle Nose)	A	66387SET3

ZIP-IT DRAIN UNCLOGGER

THE AMAZING FAST & EASY WAY TO CLEAR CLOGGED DRAINS

- Unclogs sinks, showers and tubs
- Clears drains of hair and other debris in seconds
- No dangerous or harsh chemicals are needed
- Non-Toxic
- Safe for the environment
- Fast, simple and easy to use
- Strong Poly Construction
- Made in the USA

Here's how it works!

- 1 Insert ZIP-IT into the clogged drain. Make sure to push until handle meets the top of the drain.
- 2 Pull ZIP-IT back slowly to avoid possible splashing of debris. Throw away after each use. Do not attempt to clean sharp edges. May cause serious injury.



DESCRIPTION	PART	
Zip-It Drain Unclogger	A	66300

"V" JAW PLIERS

IRWIN GROOVE LOCK "V" JAW PLIERS

- Simple push of innovative press-n-slide button adjusts lower jaw 2X faster than traditional groove joint pliers
- Multi-Groove Ratcheting System has twice the groove positions than any other groove joint pliers, providing precise jaw positioning to grip any type of surface
- Anti-pinch, non-slip ProTouch Grips provide comfort, control and less hand fatigue
- Right angle teeth grip in all directions for maximum bite
- Metal Injection Molding (MIM) process for precision parts
- Delivers strength and exceptional performance



IRWIN.
VISE-GRIP®



P/N 8814

P/N	Size	Jaw Capacity	Pipe Size	Nut Size (Across Flats)
66360	8"	1-3/4"	1"	30 mm (1.18")
66361	10"	2-1/4"	1-1/2"	40 mm (1.57")
66362	12"	2-3/4"	2"	50 mm (1.96")



DESCRIPTION

DESCRIPTION	PART	
8" Groove Lock "V" Jaw Plier	A	66360
10" Groove Lock "V" Jaw Plier	A	66361
12" Groove Lock "V" Jaw Plier	A	66362
Groove Lock "V" Jaw Pliers "3 Piece Set" (Includes: P/Ns 66360, 66361 & 66362)	A	8814

INSULATED PLIERS SET

IRWIN® VISE-GRIP® 1000V INSULATED PLIERS



Three Piece Insulated Pliers Set

- Insulated 7" Combination Pliers
- Insulated 8" Long Nose Pliers
- Insulated 6" Standard Diagonal Cutter

Features

- Individually tested at factory
- All tools meet ASTM, IEC, VDE and DIN specifications
- Strong gripper teeth
- Slim profile nose reaches into tight areas
- Hardened teeth
- Red and yellow handles denotes international color for safety
- ProTouch™ grips provide maximum comfort and reduced hand fatigue
- Lifetime guarantee

P/N 8849



P/N 66208



P/N 66209



P/N 66210

PART	DESCRIPTION	SIZE	JAW LENGTH	JAW WIDTH	JAW THICKNESS	WIRE CUTTER
66208	A Insulated 7" Combination Pliers	7"	1-1/2"	1-1/8"	7/16"	Yes
66209	A Insulated 8" Long Nose Pliers	8"	3"	13/16"	3/8"	Yes
66210	A Insulated 6" Standard Diagonal Pliers	6"	7/8"	7/8"	7/16"	Yes
8849	A Insulated Pliers 3 Piece Set (Includes: P/Ns 66208, 66209 & 66210)					

MINI TRADITIONAL PLIERS SET

IRWIN® VISE-GRIP® PLIERS

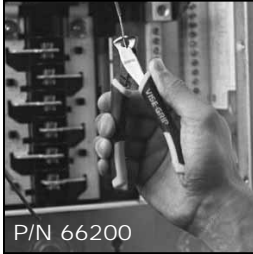

Eight Piece Mini Pliers Set Includes:

- 4-1/4" End Nipper
- 5-1/4" Flat Nose Plier
- 5-1/4" Long Nose Plier
- 4-3/4" Lineman's Plier
- 4-1/2" Flush Cut Diagonal
- 4-1/4" Diagonal Cutter
- 5-1/2" Needle Nose Plier
- 5" Bent Nose Plier

IRWIN.
VISE-GRIP®



Pliers include ProTouch™ grips which provide extra comfort and control with less hand fatigue and allow precise control on small work pieces. Included are induction hardened edges on cutting pliers and formed teeth on gripping pliers.

P/N 8817



PART	DESCRIPTION	Size	Jaw Length	Jaw Width	Jaw Thickness	Spring Loaded	Wire Cutter
66200	A 4-1/4" End Nipper with Spring	4-1/4"	5/16"	9/16"	11/32"	Yes	Yes
66201	A 5-1/4" Flat Nose Plier	5-1/4"	1-1/4"	9/16"	11/32"	Yes	No
66202	A 5-1/4" Long Nose Plier with Cutter & Spring	5-1/4"	1-1/4"	9/16"	11/32"	Yes	Yes
66203	A 4-3/4" Lineman's Pliers with Spring	4-3/4"	5/8"	9/16"	11/32"	Yes	Yes
66204	A 4-1/2" Flush Cut Diagonal Pliers with Spring	4-1/2"	17/32"	9/16"	11/32"	Yes	Yes
66205	A 4-1/2" Standard Diagonal Pliers with Spring	4-1/2"	17/32"	9/16"	11/32"	Yes	Yes
66206	A 5-1/2" Needle Nose Pliers with Spring	5-1/2"	1-11/16"	9/16"	11/32"	Yes	No
66207	A 5" Bent Nose Pliers with Spring	5"	1-1/8"	9/16"	11/32"	Yes	No
8817	A Mini Traditional Pliers Set (Includes all 8 pliers)						

MINI TRADITIONAL PLIERS

IRWIN® VISE-GRIP® PLIERS



P/N 66200

4-1/4" End Nipper with Spring

- High leverage for greater force at the jaw
- Induction hardened cutting edge that stays sharp longer
- Nickel chromium steel construction for overall strength and durability
- ProTouch™ grips
- Spring loaded – easy gripping



P/N 66204

4-1/2" Flush Cut Diagonal Pliers with Spring

- High leverage for greater force at the jaw
- Induction hardened cutting edge that stays sharp longer
- Nickel chromium steel construction for overall strength and durability
- ProTouch™ grips
- Spring loaded – easy gripping



P/N 66201

5-1/4" Flat Nose Pliers with Spring

- High leverage for greater force at the jaw
- Machined jaws for maximum gripping power
- Nickel chromium steel construction for overall strength and durability
- ProTouch™ grips
- Spring loaded – easy gripping



P/N 66205

4-1/2" Standard Diagonal Pliers with Spring

- Induction hardened cutting edge that stays sharp longer
- High leverage for greater force at the jaw
- Nickel chromium steel construction for overall strength and durability
- ProTouch™ grips
- Spring loaded – easy gripping



P/N 66202

5-1/4" Long Nose Pliers with Cutter and Spring

- Induction hardened cutting edge that stays sharp longer
- Machined jaws for maximum gripping power
- Nickel chromium steel construction for overall strength and durability
- High leverage for greater force at the jaw
- ProTouch™ grips
- Spring loaded – easy gripping



P/N 66206

5-1/2" Needle Nose Pliers

- Slim needle nose with fine tip for precision work
- Smooth jaws prevent surface marring
- Nickel chromium steel construction for overall strength and durability
- High leverage for greater force at the jaw
- ProTouch™ grips
- Spring loaded – easy gripping



P/N 66203

4-3/4" Lineman's Pliers with Spring

- Induction hardened cutting edge that stays sharp longer
- Machined jaws for maximum gripping power
- Nickel chromium steel construction for overall strength and durability
- High leverage for greater force at the jaw
- ProTouch™ grips
- Spring loaded – easy gripping



P/N 66207

5" Bent Nose Pliers

- 45° bend in nose
- Smooth jaws prevent surface marring
- Nickel chromium steel construction for overall strength and durability
- High leverage for greater force at the jaw
- ProTouch™ grips
- Spring loaded – easy gripping

SPECIALTY TOOLS

BIONIC WRENCH™

Fits 14 Wrench Sizes (SAE and Metric)

- Easy to use
 - Squeeze and turn
 - No guessing bolt sizes
- Distributes equal force on all sides of bolts
- Will not slip, strip, round off fasteners or bust knuckles
- Corrosion resistant
- Made in the USA

6" Tool – P/N 66365

Grips connections and fasteners from 1/4" to 9/16" and 7 to 14 mm

8" Tool – P/N 66367

Grips connections and fasteners from 1/2" to 3/4" and 12 to 20 mm

10" Tool – P/N 66364

Grips connections and fasteners from 3/4" to 1-1/4" and 19 to 30 mm



BIONIC GRIP WITH INTERLOCK™

For Pipes, In-line Connections & Fasteners

- Easily adjust to pipes, fasteners, and in-line connections
- Automatic interlock enhances torque
 - Squeeze and turn
- 4 jaws maximize gripping strength; minimizes tube distortion
- Corrosion resistant
- Made in the USA

6" Tool – P/N 66363

Grips pipe, connections and fasteners from 1/4" to 9/16" and 7 to 14 mm

8" Tool – P/N 66368

Grips pipe, connections and fasteners from 1/2" to 3/4" and 13 to 20 mm

10" Tool – P/N 66366

Grips pipe, connections and fasteners from 7/8" to 1-1/4" and 21 to 30 mm



BIT DR.® – RATCHETING SCREWDRIVER

Bit Dr.
Ratcheting Screwdriver



The Cure For the Common Screwdriver.

- 11 full-size drivers
- Flexible driver system
 - 6 driving positions (includes 90° torque enhancing)
 - 7 length adjustments
- Magnetic 1/4" hex drive
- Driving force engages ratchet-like function
- Compact size: 4" x 1-1/2" x 5/8"
- Hardened steel components, nickel plated for corrosion protection
- Integrated bit carriage has cushioned rubber grips
- Ergonomic molded glass-reinforced nylon handle
- Fingertip control
- Made in the USA



P/N 66369

Slotted		Phillips		Star		Square	
Size	Size	Size	Size	Size	Size	Size	Size
4-6	8-10	0	1	T 10	T 15	1	2
		2	3				

11 Driver Sizes

10 S2 Bits

VERTICAL CLAMP LOCKING TOOL

THE WORLDS SMALLEST LOCKING TOOL FOR VERTICAL CLAMPING

The MicroGrip 2000 is the worlds smallest locking tool for vertical clamping. It's a high performance tool for professionals. Made with strength and durability to last! It has an ergonomic design, with smooth rounded edges, and the single-handed locking and release action to free up the other hand for positioning work pieces. The straight line motion of the mobile jaw allows vertical clamping in tight spots.

- Length 3-5/8"
- Jaw capacity: 15/32"
- Body made of heat treated aircraft aluminum alloy
- Welding spatter resistant
- Non-corrosive & lightweight
- Adjustable Brass screw
- Mobile jaw dissipates heat
- Hollow fixed jaw allows tool to be attached/bolted to fixtures and permits connection of earth cables for efficient grounding near the weld



DESCRIPTION	PART
Microgrip 2000 Vertical Clamp Locking Tool	A 66381

SPRING CLAMPS

CLAMP WITH TUCK-IN HOOK

- 2" CLAMP CAPACITY – IDEAL FOR DEEP CLAMPING JOBS
- ERGONOMIC CLAMP GRIP IS DESIGNED FOR EASY, COMFORTABLE CLAMPING
- TUCK-IN HOOK'S 1" CAPACITY TEMPORARILY HOLDS TUBING, CABLES, DECORATIONS, ETC.
- PIVOTING V-GROOVED JAW PADS OPEN 2" WIDE TO PROVIDE FIRM, EVEN HOLD
- LIGHTWEIGHT GLASS-FILLED NYLON CONSTRUCTION IS RUST RESISTANT AND DURABLE



DESCRIPTION	PART
Clamp with Tuck-In Hook	B 66390

VACUUM BASE SPRING CLAMP

- ADHERES TO MOST NON-POROUS SURFACES
- GLASS, TILE, MIRRORS, VARNISHED WOOD OR METAL
- JAWS OPEN TO 1-1/4" WIDE ON THE 3/4" CLAMP AND 7/8" ON THE 1/2" CLAMP
- INCLUDES PIVOTING JAW PADS THAT PROVIDE A FIRM, EVEN HOLD



DESCRIPTION	PART
Vacuum Base Spring Clamp	I 66392

BIOREMEDIATION PARTS WASHER

SMARTWASHER® MOBILE PARTS/BRAKE WASHER

The SmartWasher® uses a unique technology called bioremediation. (Ozzys) breakdown “eat” the grease and oil or carbon-based products in the OzzyJuice and turn those contaminants into harmless carbon dioxide and water EVAPORATION.

Microbes (Ozzys) continuously eat the contaminants out of the OzzyJuice leaving it clean and strong every time. The microbes (Ozzys) will “eat” grease, oil, mineral spirits, solvents and other petroleum based products, just to name a few. Because of bioremediation and as long as the SmartWasher is maintained properly, the customer should NEVER have to change the fluid.

OzzyJuice Eats:

- Crude Oil
- Hydraulic Transmission Fluid
- Cutting Oils
- Ink/Toner
- Asphalt
- Burned-On Carbon
- Automotive Varnish
- Animal Fat
- Impacted Grease
- Fifth Wheel Grease
- Resin Products
- Automotive Grease
- Bearing Grease
- Solder & Flux
- Motor Oil
- Creosote



SmartWasher®
P/N 27723

27

Overall Dimensions	43" x 27" x 42"
Inside Sink Dimensions	27" x 23" x 8"
Parts Washer Structure	Heavy-Duty HDPE
Controls	Toggle Switch
Pump Capacity	300 gph
Adjustable Thermostat	105° to 115° F
Flow Control Timer	10 Minutes
Standard Equipment	Customized Dolly
Certified	ETL (UL/CSA), CE, NSF
SmartWasher Start-up Kit	Ships completely assembled, with one OzzyMat™ and enough OzzyJuice® to get started.



OzzyJuice® Parts/Brake Solution
P/N 27724

OzzyJuice® Degreaser Solution
P/N 27726

OzzyJuice® Truck Degreasing Solution
P/N 27727

OzzyJuice® Metal Degreasing Solution
P/N 27728

OzzyJuice® Aircraft/Weapon Degreaser
P/N 27729

OzzyJuice® Heavy Duty Degreaser Solution
P/N 27731



OzzyMat™ Multi-Layer Fluid Activator
P/N 27725

OzzyMat™ Single Layer Fluid Activator
P/N 27730

BIOREMEDIATION PARTS WASHER

OVERVIEW OF SMARTWASHER® SYSTEMS



SmartWasher® Mobile Parts/Brake Washer

P/N 27723

- 300 gph Pump
- Onboard Diagnostics / Adjustable Thermostat
- Load Capacity of 550 lbs.
- Overall Dimensions: 43" x 27" x 42"
- Inside Sink Dimensions: 27" x 23" x 8"
- Customized Dolly
- No Health & Safety Hazards
- No Environmental Damage
- No Toxic Solvents
- No Service Contracts
- No Waste Hauling
- No Flash Point



SmartWasher® Signature

P/N 27722

- 300 gph Pump
- Onboard Diagnostics
- Adjustable Thermostat
- Load Capacity of 550 lbs.
- Overall Dimensions: 39" x 29" x 40"
- Inside Sink Dimensions: 26" x 17" x 8"
- No Health & Safety Hazards
- No Environmental Damage
- No Toxic Solvents
- No Service Contracts
- No Waste Hauling
- No Flash Point



SmartWasher® Super Sink XE

P/N 27721

- 300 gph Pump
- Onboard Diagnostics / Adjustable Thermostat
- Load Capacity of 550 lbs.
- Overall Dimensions: 47" x 38" x 42"
- Inside Sink Dimensions: 41" x 26" x 8"
- 2 brush stations, light kit and parts basket
- No Health & Safety Hazards
- No Environmental Damage
- No Toxic Solvents
- No Service Contracts
- No Waste Hauling
- No Flash Point



SmartWasher® Super Sink

P/N 27720

- 300 gph Pump
- Onboard Diagnostics
- Adjustable Thermostat
- Load Capacity of 550 lbs.
- Overall Dimensions: 47" x 38" x 42"
- Inside Sink Dimensions: 41" x 26" x 8"
- No Health & Safety Hazards
- No Environmental Damage
- No Toxic Solvents
- No Service Contracts
- No Waste Hauling
- No Flash Point

All SmartWashers ship completely assembled with one OzzyMat™ & enough OzzyJuice® to get started.

INDUSTRIAL QUALITY TAPE

3M™ VHB™ HEAVY DUTY MOUNTING TAPES

The Convenience and Simplicity of a Tape Fastener. Ideal for use in many interior & exterior bonding applications and in many situations.

- Can replace rivets, spot welds, liquid adhesives and other permanent fasteners.
- Made with acrylic foam which is viscoelastic in nature. This gives the foam energy absorbing and stress relaxing properties which provides these tapes with their unique characteristics.
- The acrylic chemistry provides outstanding durability performance. These tapes utilize a variety of specific foam, adhesive, color and release liner types to provide each product/family with specific features.
- These features can include adhesion to specific or a broad range of materials, conformability, high tensile strength, high shear and peel adhesion, resistance to plasticizer migration, and UL746C recognition. 3M™ VHB™ Tapes have excellent durability and excellent solvent and moisture resistance.



VHB = Very High Bond

Black Tape, P/N 28762

3/4" x 15 yds / 45 mil

Matches the modified acrylic adhesive on both sides of very conformable foam, providing adhesion to the broadest range of substrates, including most powder coated paints.

Clear Tape, P/N 28763

3/4" x 15 yds / 40 mil

Excellent for applications where clear or colorless is desired. The general purpose adhesive on both sides is suitable for high surface energy substrates.

DESCRIPTION	PART	
3M BLACK TAPE "VHB" – 3/4" x 15 yds, 45 mil	A	28762
3M CLEAR TAPE "VHB" – 3/4" x 15 yds, 40 mil	A	28763

INDUSTRIAL QUALITY TAPE

3M™ TEMFLEX™ COTTON FRICTION TAPE 1755

Cotton Cloth with Thermosettable Rubber Resin

3M™ Temflex™ Cotton Friction Tape 1755 is a high-grade, black friction tape designed to provide mechanical protection against abrasion and cut-through for cable, wire splices and connections insulated with rubber electrical tape.

The 13 mil thick tape is composed of a high-quality cotton fabric, coated on both sides with an electrical-grade, solvent-free, rubber adhesive.

1755 Tape has high break strength and low stretch, making it ideal as a heavy-duty binding and harnessing tape.

- Provide abrasion and cut-through protection on wire and cable splices
- Provide mechanical protection for rubber electrical tape
- Provide bundling, binding and spot holding on wire harnesses
- Provide protection on sharp edges, to prevent scratching or cut through



DESCRIPTION	PART
3M TEMFLEX COTTON FRICTION TAPE 1755 – 1" x 60', 13 mil	A 28774

SCOTCH™ GLASS CLOTH ELECTRICAL TAPE 27 & 69

Class “B” and “H” Insulation

Ideal for holding and strapping applications up to 200°C.

3M offers exceptionally flexible and conformable glass cloth backings on the market with high-temperature resistance and tensile strength. With excellent absorption of resins and varnishes plus cut-through and edge-tear resistance.



27 Tape

This is a 7 mil woven glass cloth tape with a **rubber thermosetting** pressure-sensitive adhesive sold on a 3 in paper core in bulk, and is for electrical OEM customers. UL Recognized 150°C. Printable.

69 Tape

This is a 7 mil woven glass cloth tape with a **silicone** pressure-sensitive adhesive sold on a 3 inch core in bulk, and is for electrical OEM customers. UL Recognized 200°C. Printable.

DESCRIPTION	PART
SCOTCH GLASS CLOTH ELECTRICAL TAPE 27 – 3/4" x 66'	A 28772
SCOTCH GLASS CLOTH ELECTRICAL TAPE 69 – 3/4" x 66'	A 28773

INDUSTRIAL QUALITY TAPE

HI-STRENGTH DOUBLE-SIDED TAPE

- BLACK POLYETHYLENE FOAM TAPE (1/32" THICK) WITH A HEAVY COATING OF AN AGGRESSIVE, HIGH PERFORMANCE, ACRYLIC ADHESIVE ON BOTH SIDES
- THE CLOSED CELL POLYETHYLENE FOAM RETAINS ITS FLEXIBILITY MAKING IT IDEAL FOR APPLICATION ON IRREGULAR OR EMBOSSED SURFACES EXPOSED TO EXTREME TEMPERATURE AND HUMIDITY
- ACRYLIC ADHESIVE STRENGTH INCREASES WITH AGE
- RESISTANT TO SOLVENTS AND CHEMICALS
- FOR MOUNTING EXTERIOR TRIM, SIDE MOULDINGS, EMBLEMS, NAMEPLATES



SIZE	PART
1/2" x 50' moulding tape	A 28761
3/4" x 50' mounting tape	A 28771

ANTI-SEIZE TAPE

- EASY TO APPLY FROM HANDY PLASTIC SPOOL
- DISCOURAGES SEIZING, GALLING AND CARBON FUSING
- NON-TOXIC, NON-FLAMMABLE, NON-STAINING
- INHIBITS CORROSION, RUSTING AND GALVANIC PITTING
- EFFECTIVE ACROSS A BROAD RANGE OF TEMPS.: -450°F to 2600°F (-268° TO 1426°C)
- WILL NOT SQUEEZE OUT AND RUB OFF LIKE GREASE BASED PRODUCTS
- COMPATIBLE WITH A WIDE RANGE OF CHEMICALS
- MEETS MIL SPECS: T-27730A (ASG) & A-A-58092
- ALSO USE FOR SEALING STAINLESS STEEL PIPE & FITTINGS

COPPER: For cleaner high-temperature threaded anti-seize applications. Reduces required torque. Applied easily, seals tightly, overcomes high temperature seizing. *Temp. range: -450° to 1800°F*

NICKEL: For applications where copper cannot be used including chemical, extremely high temperatures, and harsher environments. Made specifically for stainless steel threads. *Temp. range: -450° to 2600°F*

CERAMIC: Formulated specifically for anti-seize applications typical to food industry. All materials FDA approved. *Temperature range: -450° to 2100°F*



SIZE	PART
1/2" x 600" Copper	B 32902
1/2" x 600" Nickel	B 32903
1/2" x 600" Ceramic	B 32904

BLUE PAINTER'S MASKING TAPE

- REMOVES CLEANLY AND EASILY WITHOUT ADHESIVE TRANSFER OR SURFACE DAMAGE UP TO 14 DAYS, EVEN IN DIRECT SUNLIGHT
- MEDIUM ADHESION
- IDEAL FOR PAINTED WALLS, TRIM, WOODWORK, GLASS AND METAL



SIZE	PART
1/2" x 60 yd Blue Painter's	A 32875
1" x 60 yd Blue Painter's	A 32876
2" x 60 yd Blue Painter's	A 32877

PTFE PIPE TAPE

High Density PTFE Tape and Yellow Gas Line:

Meets: MIL-T-27730 & CID A-A-58092
CSA Requirement #4-90
4 Mil Thickness



Standard and Import PTFE Tape:

Meets: MIL-T-27730A 3.5 Mil Thickness

- TEMPERATURE RANGE -400°F to 500°F (-240°C to 260°C)
- FORMS A PERMANENT SEAL FOR THE LIFE OF THE CONNECTION
- APPROVED BY THE USDA AND FDA AND ARE NON-TOXIC UNDER NORMAL USAGE (DO NOT BURN, PTFE MATERIALS EMIT A TOXIC GAS IF INCINERATED)
- ALL PIPE JOINT SEALING APPLICATIONS
- AVAILABLE IN HIGH DENSITY, STANDARD OR LOW DENSITY COMPOSITIONS
- GREEN/OXYGEN TAPE IS SUITABLE FOR OXYGEN SERVICE SUCH AS HOSPITAL EQUIPMENT AND OXYGEN CYLINDERS
- PINK/PLUMBERS TAPE IS EXTRA THICK AND EXTRA DENSE FOR PIPE-FITTING

SIZE	PART
High Density 1/2" x 520"	E 32890
High Density 3/4" x 520"	E 32891
Standard 1/2" x 520"	I 2895
Standard 3/4" x 520"	E 32895
Low Density 1/2" x 520"	I 32892
Low Density 3/4" x 520"	I 32893
Yellow Gas Line 1/2" x 520"	E 32898
Yellow Gas Line 3/4" x 520"	E 32899
Green/Oxygen 1/2" x 260"	E 32900
Pink/Plumbers 1/2" x 260"	E 32901

MASKING TAPE

- STRONG MASKING TAPE FOR LOW AND HIGH TEMPERATURE USE (TO 200°F)
- HIGH TACK ADHESIVE
- CLEAN REMOVABILITY
- TOP MOISTURE RESISTANCE



SIZE	PART	SIZE	PART
1" x 180'	E 2896	2" x 180'	E 2897

MASKING TAPE DROP CLOTH



- MASKING TAPE, MASKING PAPER AND CLEAR FILM IN ONE – SIMPLY UNROLL, APPLY AND UNFOLD FILM
- CLEAR FILM CLINGS TO SURFACE FOR MAXIMUM COVERAGE AND EFFECTIVENESS
- HANDY DISPENSER W/CUTTING BLADE
- WORKS AT TEMPS UP TO 250°F (120°C)
- SAVES TIME & MONEY – CAN BE APPLIED BY ONE PERSON

DESCRIPTION	PART
78" x 22 YARD ROLL	A 32897
DISPENSER	A 32896

INDUSTRIAL QUALITY TAPE

DUCT SEALING SHEETS

- PERFECT FOR THE REPAIR OF TENTS, TARPS, AUTO/BOAT UPHOLSTERY, LUGGAGE SPORTS EQUIPMENT, ETC.
- SIMPLY REMOVE THE SHEET FROM THE RELEASE LINER PRESS INTO PLACE
- CAN ALSO BE CUT FOR A CUSTOM FIT

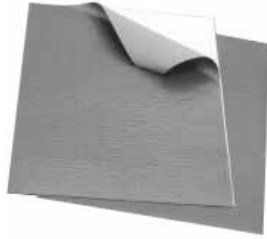

DESCRIPTION	PART
Duct Sealing Sheets 8-1/2" x 11"	1 32870
Duct Sealing Sheets 4" x 4"	1 32871

DOUBLE SIDED FOAM TAPE

- COATED WITH AN ACRYLIC PRESSURE SENSITIVE ADHESIVE PROVIDES HIGH ULTIMATE BOND AND SHEAR STRENGTH
- IDEAL FOR GENERAL PURPOSE MOUNTING AND JOINING
- HIGH TEMPERATURE RESISTANCE TO 220°F (104°C)
- HIGH SOLVENT RESISTANCE
- BONDS MIRRORS TO WALLS OR FURNITURE
- BONDS ACOUSTIC PANELS TO WALLS
- MOUNT AIR FRESHENERS AND SOAP DISPENSERS
- MOUNT INTERIOR SIGNS AND NAMEPLATES



DESCRIPTION	PART
1/16 x 1" x 36 yard roll	A 2881
1/8 x 1" x 36 yard roll	A 28818

CLEAR DUCT SEALING

- CLEAR DUCT TAPE MAKES REPAIRS LESS OBVIOUS
- UV AND WATER RESISTANT FOR BOTH INDOOR & OUTDOOR USE
- CAN BE TORN LENGTHWISE AND CROSSWISE FOR ADDED CONVENIENCE AND VERSATILITY
- LASTS UP TO 6 TIMES LONGER THAN OTHER HEAVY-DUTY DUCT TAPE BASED ON ACCELERATED WEATHERING
- UNWINDS AND SEPARATES EASILY, EVEN WHEN THE STICK SIDES MEET



DESCRIPTION	PART
Clear Duct Sealing 2" x 60'	A 42885

CAMOUFLAGE TAPE (MATTE FINISH)

- INSTANTLY CAMOUFLAGES ALL TYPES OF HUNTING AND OUTDOOR GEAR
- DESIGNED TO BE CUT AND TRIMMED TO COVER ODDLY SHAPED OR MOVING PARTS SUCH AS SCOPE KNOBS & OTHER FUNCTIONAL CONTROLS
- IMPROVES GRIP, QUIETS CLANKING GEAR, AND PROTECTS EXPENSIVE EQUIPMENT FROM SCRATCHES
- INSULATES HANDS FROM HOT AND COLD SURFACES
- WEATHER RESISTANT AND WATERPROOF
- KEEPS FIREARMS AND BOWS FROM SLIPPING ON ROCKS, STEEP TERRAIN, BRANCHES, TREE STANDS AND OTHER SURFACES
- IDEAL FOR CAMOUFLAGING ITEMS SUCH AS OUTBOARD MOTORS, OARS, FLASHLIGHTS, SMALL COOLERS, THERMOSES, DOG COLLARS AND OTHER GEAR



SIZE	PART
2" x 180' Camouflage Tape	A 32874

COLORED DUCT SEALING

- POLYETHYLENE COATED CLOTH TAPE
- AVAILABLE IN SEVEN (7) COLORS: SILVER, BLACK, RED, WHITE, BLUE, YELLOW & GREEN
- HIGHEST ADHESION AND MOISTURE RESISTANCE
- EASY TEARING
- FOR COLD OR HOT AIR DUCTS



SIZE AND COLOR	PART
2" x 180' Silver	A 2885
3" x 180' Silver	A 2887
2" x 180' Black	A 2885BK
2" x 180' Red	A 2885R
2" x 180' White	A 2885W
2" x 180' Blue	A 2885BL
2" x 180' Yellow	A 2885Y
2" x 180' Green	A 2885G

GLASS REINFORCED FILAMENT

- TOUGH – 180 LBS. / INCH PSI
- EXCELLENT SCUFF AND MOISTURE RESISTANCE
- RESISTS LENGTHWISE SPLITTING
- USE FOR TABBING, BUNDLING, UNITIZING, PROTECTING, ETC.



SIZE	PART
1" x 180' Glass Reinforced	A 2882

ANTI-SLIP TAPES

ANTI-SLIP TAPES - COLORS - 46/50/60 GRIT



Anti-Slip Tape is the preferred product line when visual warning is required to mark potential slip and fall hazards. Developed with maximum visual warning characteristics in mind. We provide the best assortment of visual cues to meet your requirements. Anti-Slip Tape is offered in 60 ft. rolls and easy to apply sections.



Features and Benefits

- Durable high traction grit surface
- Easy to apply
- Aggressive adhesive system for product longevity
- Fuel, water and fluid resistant
- Reduce the risks of slips and falls
- Ensure worker safety on potentially hazardous surfaces
- Prevent costly injuries in the workplace due to slips and falls
- Reduce Worker's Compensation claims
- NFSI - National Flooring Safety Institute certified for "high traction"
- Exceeds OSHA standards for non-slip protection on walking surfaces



Applications

- Farm Machinery
- Construction equipment
- Forklifts
- Cherry pickers
- Steps, stairs
- RVs
- Snowmobiles
- ATVs
- Garden tractors
- Lawn mowers
- Wet & oily areas
- Loading docks
- Cold storage
- Catwalks
- Platforms/ramps
- Ladders, step stools
- Scaffolds
- Airline decks
- Airline cargo holds
- Trains
- Semi-trailers
- Buses
- Ship decks
- Boats
- Conveyors
- Pulleys
- Food service areas
- Machine shops
- Auto repair shops
- Garages

DESCRIPTION	PART	DESCRIPTION	PART
2" x 60' Roll, 46 Grit, Black	A 28207	4" x 60' Roll, 60 Grit, Yellow	A 28265
4" x 60' Roll, 46 Grit, Black	A 28208	6" x 60' Roll, 60 Grit, Yellow	A 28266
6" x 60' Roll, 46 Grit, Black	A 28209	2" x 60' Roll, 60 Grit, Yellow/Black	A 28267
2" x 60' Roll, 60 Grit, Red	A 28261	4" x 60' Roll, 60 Grit, Yellow/Black	A 28268
4" x 60' Roll, 60 Grit, Red	A 28262	6" x 60' Roll, 60 Grit, Yellow/Black	A 28269
6" x 60' Roll, 60 Grit, Red	A 28263	6" x 24" Piece, 60 Grit, Caution	A 28215
2" x 60' Roll, 60 Grit, Yellow	A 28264	6" x 24" Piece, 60 Grit, Watch Your Step	A 28260

ANTI-SLIP TAPES - LOW PROFILE

- PREVENTS SLIPS AND FALLS ON SLIPPERY SURFACES
- ABRASIVE GRAIN COATED PLASTIC FILM WITH PRESSURE SENSITIVE ADHESIVE
- SUPERIOR QUALITY MATERIALS - ASSURES LONG LIFE, DURABILITY AND RESISTANCE TO HEAVY TRAFFIC, WATER AND GREASE
- ABRASIVE GRAIN - PROVIDES A CONSISTENT CO-EFFICIENT OF FRICTION
- EASY INSTALLATION - SIMPLY POSITION, PEEL-OFF BACKING PAPER AND APPLY TO A CLEAN, DRY, OIL-FREE SURFACE
- CONFORMABILITY - INSTALLS OVER MOST IRREGULAR SURFACES
- LOW PROFILE HELPS PREVENT EDGE CURL
- MEETS OR EXCEEDS MOTOR VEHICLE SAFETY STANDARD NO. 302, MIL-D-17951E (SHIPS), AND NON-SLIP MIL-W-5044C TYPE IV

Surface Compatibility: Painted wood, painted metal, sealed concrete

Application Temperature: Apply when above 50°F



DESCRIPTION	PART
2" x 60' roll	A 28210
4" x 60' roll	A 28211

ANTI-SLIP TAPES

ANTI-SLIP TAPES - GLOW-IN-THE-DARK - 50 GRIT



The ultimate non-slip egress tape! Sudden power outages or natural disasters can increase the potential for panic, as well as the risk of injuries caused by slips and falls.

Safety grade glow-in-the-dark solution for marking stairs and corridors that are part of the emergency egress route. Offered in 60 ft. rolls.

Features and Benefits

- Manufactured with the same aggressive adhesive system as our other safety tape products
- Complies with all safety grade photoluminescent domestic and international standards
- It will adhere to most clean, dry, oil-free surfaces
- For use on painted wood, metal, sealed concrete and non-porous surfaces
- NFSI - National Flooring Safety Institute certified for "high traction"



DESCRIPTION	PART	
2" x 60' Roll, 50 Grit, Glow-in-the-Dark	A	28212
4" x 60' Roll, 50 Grit, Glow-in-the-Dark	A	28213
6" x 60' Roll, 50 Grit, Glow-in-the-Dark	A	28214

BARRICADE TAPE

CAUTION DO NOT ENTER / DANGER DO NOT ENTER

CAUTION DO NOT ENTER

DANGER DO NOT ENTER

- Roll length: 1000'
- Roll width: 3"
- Thickness: 2 mil
- Standards OSHA 1910.144
- YELLOW OR RED film with BLACK print
- Durable polyethylene
- Continuous repeating message or warning in bold black letters
- For visual warning in hazardous areas
- Temporarily control and secure identified areas on an immediate basis
- Protect pedestrians, employees and anyone who might fall into a dangerous situation



APPLICATIONS

- Road Work
- Construction Sites
- Chemical and industrial plants
- Fire and crime scenes
- Any potential dangerous areas

DESCRIPTION	PART	
Barricade Tape (YELLOW WITH BLACK TYPE - CAUTION DO NOT ENTER) 1000' Roll	A	20098
Barricade Tape (RED WITH BLACK TYPE - DANGER DO NOT ENTER) 1000' Roll	A	20099

AIR BLOW GUNS

SAFETY BLOW GUN

- Ergonomic design fits in your hand comfortably
 - Composite body and nozzle will not scratch – sturdy and durable
 - Light weight (4.8 oz.)
 - 1/4" female brass insert to match any plug profile
 - Built-in hole on body so it can hang up easily on hook
 - The shape of the trigger will not allow any dust or material inside the gun
 - It operates with a double O-ring seal and stainless steel spring
 - Built-in trigger stop at the handle base. Prevents the handle from being over extended and fatigued
 - Trigger and nozzle angle are shaped in the natural air flow of the gun
- 7.7 SCFM @ 87 PSI
 - 90 db rating
 - Blower Force - 9.5 Oz
 - Dynamic Pressure @ 87 PSI = 17.40 PSI



DESCRIPTION	PART
Safety Blowgun with OSHA Venturi Nozzle	A 52233

POCKET BLO-GUN



"M" STYLE



"T" STYLE

EASY GRIP TWO FINGER AIR CONTROL ADJUSTS FROM WHISPER TO FULL VOLUME AIR FLOW

DESCRIPTION	PART
Fits 1/4 "M" style coupler body	A 52224
Fits 1/4 "T" style coupler body	A 52226

RUBBER TIP BLO-GUN



- FULL LINE PRESSURE
- HEAVY DUTY
- LEAK-PROOF CONNECTION FOR BLOWING OUT FLUID LINES
- WON'T MAR DELICATE OR PAINTED SURFACES

DESCRIPTION	PART
1/4" NPT Air Inlet with Rubber Tip	A 52230

SAFETY LEVER BLO-GUN



- FULL FLOW
- LEVER EASILY CONTROLS AIR FLOW
- HUNDREDS OF AUTOMOTIVE/ INDUSTRIAL USES
- RUGGED CONSTRUCTION
- MEETS OSHA REQUIREMENTS

DESCRIPTION	PART
1/4" NPT Air Inlet Nozzle Thread 7/16-27	A 52228
1/4" NPT Air Inlet w/Hang-Up Hook Nozzle Thread 1/8-27	A 52229

WELDLESS CHAIN

HEAVY ZINC COATING

Made of high quality, silver bright, galvanized steel wire. Galvanized wire is superior in rust resistance because of a heavier zinc coating than zinc plated chain. Not for lifting.

DOUBLE LOOP CHAIN

- A GENERAL UTILITY CHAIN FOR MULTIPLE APPLICATIONS SUCH AS PORCH SWINGS, CHILDREN'S SWINGS, ANIMAL CHAINS AND LIGHT FIXTURES
- 100 FOOT LENGTHS

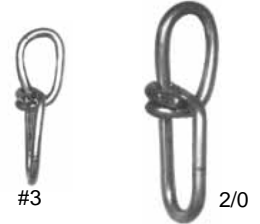

SIZE	WIRE GAUGE	WIRE DIAMETER, INCHES	LINKS PER FOOT	WEIGHT PER 100' POUNDS	WORKING LOAD LIMIT POUNDS	BREAK TEST LOAD, POUNDS	PART
#3	14	.080	10.5	6.1	90	360	T 60518
2/0	10	.135	6.6	17	255	1020	T 60519

SINGLE JACK CHAIN

- IDEAL FOR HANGING SIGNS, LIGHTING FIXTURES AND NOVELTIES SUCH AS FLOWER POTS, CHILDREN'S TOYS AND OTHER GENERAL UTILITY APPLICATIONS
- 100 FOOT LENGTHS



SIZE	WIRE GAUGE	WIRE DIAMETER, INCHES	LINKS PER FOOT	WEIGHT PER 100' POUNDS	WORKING LOAD LIMIT POUNDS	BREAK TEST LOAD, POUNDS	PART
16	16	.062	23	3.0	10	40	T 60520
12	12	.105	16	8.5	29	115	T 60521

SASH CHAIN

- SUITABLE FOR APPLICATIONS REQUIRING FLAT METAL CHAIN AND OPERATION OVER PULLEYS SUCH AS WINDOWS AND SASHES
- 100 FOOT LENGTHS



SIZE	MATERIAL SIZE INCHES	LENGTH PER 100 LINKS	APPROXIMATE WEIGHT PER 100 FEET	WORKING LOAD LIMIT POUNDS	MIN. BREAK TEST LOAD, POUNDS	PART
35	.035	56	6	106	425	T 60522

NOTE: Weights are for steel chain only and are subject to a plus or minus tolerance of 4%.

INSTANT HOOK

THE BAT HOOK®

The Instant Hook That Hangs Like A Bat!

Features

- The perfect detachable hanging solution for a multitude of storage and organizational tasks
- In just seconds, and without the need of tools or fasteners, the Bat Hook® turns underutilized wood studs and beams into highly adaptable storage space
- Firmly attaches at any angle, onto wood studs, rafters, and joists
- Just squeeze the patented “cantilevered point” clamping mechanism & slip it over any “two by” board
- Holding up to 40 lbs, the Bat Hook® grips the wood surface tighter as more load is attached
- Made from high strength galvanized steel

Benefits

- Unmatched versatility and strength
- Will withstand years of use and infinite moves
- No need for tools or fasteners

Use In

- Garages
- Basements
- Sheds
- Attics
- Decks
- Job Sites

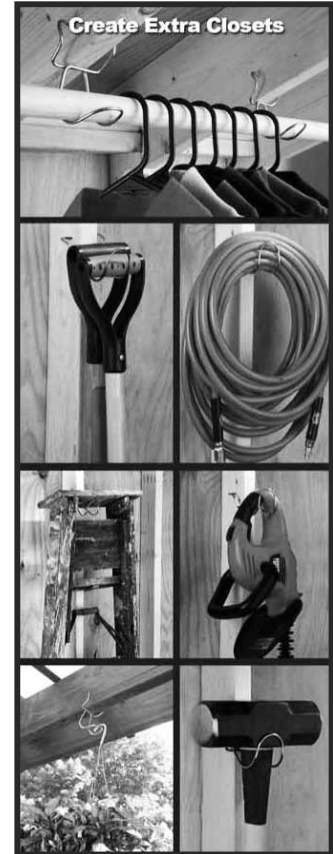

DESCRIPTION	PART
The Bat Hook – Instant Hook	A 60366

DRIP PAN – RUBBER

DURABLE REINFORCED RUBBER COMPOSITION

Features

- 3 gallon containment
- Low and wide (17" Dia. x 4-1/2" H)
- Reusable
- Flexible rubber
- Will not crack if dropped
- Extremely resistant to cold weather cracking
- No damage if run over by vehicle

Applications

- Garages
- Motorpools
- Bleeding brake lines
- Oil changes
- Transmission fluid changes
- Soaking and cleaning parts or tools
- Anywhere leaks or spills are possible



DESCRIPTION	PART
Rubber Drip Pan	A 28309

SPILL CONTAINMENT – UNIVERSAL

FLUID ABSORBENTS – UNIVERSAL

Universal Rolls, Pads, Socks, and Drum Tops are made with Q-CEL™ technology! Q-CEL™ technology is the most significant absorbent development in almost 20 years! Industry Leading... You can take care of almost 90% of your industrial spill control with just a few absorbents.

Universal Absorbent Rolls

The market leader in absorbency vs. major competitors. Use for oil and water applications only, not for use with aggressive acids or caustics. The rolls have perforated tear-off sheets every 19". Made with recycled fibers. Class A fire retardant.



Universal Absorbent Pads

The market leader in absorbency vs. major competitors. Use for oil and water applications only, not for use with aggressive acids or caustics. Made with recycled fibers. Class A fire retardant.



Universal Absorbent Socks

Designed to meet the absorbency that you expect. Our socks provide great moldability in the workplace, ensuring the perfect fit for each job. Packed with our recycled fibers to help save our environment and yet is still a fast-acting sorbent.

Definitely one of our best products yet! Use for oil and water applications only, not for use with aggressive acids or caustics. Made with recycled fibers. Class A fire retardant.



Drum Tops

Big bulk, laminated Drum Top Pads, keep liquids from getting to the floor so there is no messy or hazardous cleanup. Use for oil and water applications only, not for use with aggressive acids or caustics. Made with recycled fibers. Class A fire retardant.



DESCRIPTION	PART
Universal Absorbent Roll, 28.5" x 125', perforated	A 28222
Universal Absorbent Socks, Gray Socks, 3" x 45"	I 28218
Universal Absorbent Pads, Gray Pads, 15" x 19", Laminated – Standard	T 28219
Drum Top Absorbent 22"	I 28224

FLUID ABSORBENTS – UNIVERSAL SPILL KIT – PORTABLE 10" BUCKET

Universal Spill Kit

Designed to handle small and medium spills. Universal absorbents are packed inside our patented bucket to keep the contents inside safe from liquids. Use for oil and water applications only, not for use with aggressive acids or caustics. Made with recycled fibers. Class A fire retardant.

Spill Kit Contents:

- 6 Universal Pads (Basic Version)
- 2 Universal Socks
- 1 Hazardous Waste Disposal Bag (with plastic tie)
- 1 Pair Industrial Gloves

P/N 28230



CHROMAGIC SPILL ABSORBENT

- One absorbent for multiple types of spills
- Non-toxic and non-flammable
- Odor Free
- Environmentally safe & friendly
- 15 times more absorbent than clay based products
- Lightweight – Up to 20 times lighter than clay based products
- Will save money on shipping, storing and disposal
- Instant clean up saves time
- Meets or exceeds all OSHA and EPA requirements
- It picks up oily sheen
- Less accidents reduce Workers' Compensation
- Lightweight and powerful
- Absorbs and holds most liquids
- One pound of Chromagic can completely absorb one quart of motor oil; clay, earth, and sand products require 15 pounds of material

- Requires far less absorbent to capture a spill
- Works on all animal, vegetable, mineral, petroleum based or semi-liquid spills
- Chromagic does not, under OSHA standards, qualify as a carcinogen, or as a substance causing silicosis, a lung disease
- Non-injurious to most surfaces including cement, asphalt, tile, and carpet



P/N 28234

Sold as a twin pack.

CAUTION:
Cannot be used to absorb Hydrofluoric Acid (HF)

SPILL CONTAINMENT – OIL ONLY

OIL EATER ABSORBENT DRIP PAN

The new Oil Eater Absorbent Drip pan is designed for leaks that occur in tight spaces – such as under machinery and pipes – and are too big for an absorbent pad. The Drip Pan is made of sturdy plastic and houses an eco-friendly absorbent pillow made of plant fibers and other renewable resources. When soiled, the pillow is easily removed and replaced with a new one.



DESCRIPTION	PART
Drip Pan (10" x 12" x 2")	A 28231
Replacement Pillow	A 28232

OIL ONLY ROLLS

- Oil Only Rolls are made with meltblown polypropylene.
- They are a standard grade absorbent used for oil spills.
- The rolls have perforated tear-off sheets every 19".



DESCRIPTION	PART
Oil Only Absorbent Roll, 36" x 130', Perforated	A 28223

OIL ONLY SPILL CONTAINMENT KIT – PORTABLE FIVE-GALLON PAIL

Take everything you need to clean up hazardous materials directly at the spill site.

Includes:

- 5 sorbent socks
- 5 sorbent sheets
- One pair of nitrile gloves
- Polyethylene pail with cover

Features and Benefits

- Oil only kit – Will not absorb water
- Ideal for service vehicles and for other confined areas
- Use in multiple locations
- Compact – Easy storage
- Light weight: 12 lbs
- Helps you in complying with EPA 40 CFR263.30 (a)



DESCRIPTION	PART
Oil Only Spill Containment Kit	A 28228

TRACK MAT – RAILROAD CONTAINMENT ABSORBENT

For Preventing or Controlling Oil Spills, Leaks, and Drips

The Track Mat is capable of absorbing nearly three gallons of oil or other petroleum products per square yard.

Our Track Mat is the heaviest, thickest and most absorbent barrier mat available. Its unique 3-ply construction includes an oil only polypropylene core, surrounded by an impenetrable barrier film that prevents absorbed liquids from leaching out. It also has a UV resistant cover-stock, providing an outdoor life of 12 to 18 months.

The Track Mat was originally designed for use between and outside railroad tracks, it is also widely used by transportation companies, utilities, refineries, steel mills, and in other environments in which a high absorbency barrier is required.



DESCRIPTION	PART
Track Mat Inner Roll, 59" x 100'	A 28226
Track Mat Outer Roll, 19" x 100'	B 28227

SPILL CONTAINMENT

FINE FIBER MELTBLOWN PADS AND ROLLS - UNIVERSAL/MAINTENANCE

- Top and bottom layers of fine fiber are built of densely-woven, small-diameter strands of fiber to increase surface area, enabling the mat to grip the floor and secure it for safe walking.
- A 3-ply construction with a layer of melt blown polypropylene ultrasonically sandwiched between two fine fiber layers makes this mat virtually indestructible to foot traffic.
- Polypropylene fibers creates a high-loft inner layer.



DESCRIPTION	PART	
Medium weight pads – gray, 15" x 19", 21 gallons sorbent capacity	T	28310*
Double weight roll – gray, 30" x 150', 50 gallons sorbent capacity	A	28311
Single weight roll – gray, 30" x 300', 50 gallons sorbent capacity	A	28312

BONDED MELTBLOWN PADS AND ROLLS - OIL ONLY

- Twin Bonded layers of melt blown polypropylene creates high surface area.
- The mat to sucks up liquid quickly and keeps its shape when fully saturated.
- Twin layered random assembly of large diameter melt blown polypropylene fibers creates a high loft inner layer.
- Ultrasonic weld points fuse the layers of melt blown polypropylene fibers together.



DESCRIPTION	PART	
Double weight pads – white, 15" x 19", 30 gallons/bale sorbent capacity	T	28313
Double weight roll – white, 30" x 150', 56 gallons/roll sorbent capacity	A	28314
Single weight roll – white, 30" x 300', 59 gallons/roll sorbent capacity	A	28315

STANDARD MELTBLOWN PADS - OIL ONLY

- Loose stacked-weave construction increases surface area on spill.
- Starts absorbing on contact.
- Fibers are left in their natural hydrophobic state.
- Hydrophobic fibers repel water (and float) while only absorbing oils and other hydrocarbons.



DESCRIPTION	PART	
Double weight pads – white, 15" x 19", 34 gallons/bale sorbent capacity	T	28316*
Medium weight pads – white, 15" x 19", 27 gallons/bale sorbent capacity	U	28317*
Single weight pads – white, 15" x 19", 36 gallons/bale sorbent capacity	U	28318*

BOOMS - OIL ONLY

- Strong mesh outer skin encases a poly sock sleeve filled with highly sorbent polypropylene.
- Filler won't shed and booms won't sink, even when saturated with oil.
- Built in connectors link booms together.



DESCRIPTION	PART	
Lint-free absorbent boom – white, 5" x 10', 35 gallons/bale sorbent capacity	D	28319

*Stock item. For all other part numbers, please allow up to 10 days after receipt of order for delivery.

SPILL CONTAINMENT

SORBENT SOCKS - OIL ONLY

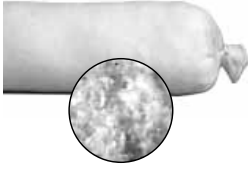

- Ideal for surrounding spilled fluids to keep them from spreading.
- Easy and convenient to put into place.
- Conforms to the base of leaky machines.
- Fits snugly to absorb leaking fluids before they spread to walk areas and become slippery hazards.

DESCRIPTION	PART	
Oil-only absorbent sock – white, 3" x 4', 30 gallons/case sorbent capacity	o	28320
Oil-only absorbent sock – white, 3" x 8', 30 gallons/case sorbent capacity	k	28321

SORBENT SOCKS - UNIVERSAL/MAINTENANCE

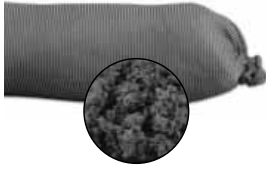

- Ideal for surrounding spilled fluids to keep them from spreading.
- Easy and convenient to put into place.
- Conforms to the base of leaky machines.
- Fits snugly to absorb leaking fluids before they spread to walk areas and become slippery hazards.

DESCRIPTION	PART	
Universal absorbent sock – gray, 3" x 4', 30 gallons/case sorbent capacity	o	28322
Universal absorbent sock – gray, 3" x 8', 30 gallons/case sorbent capacity	k	28323

SPILL KITS - OIL ONLY, UNIVERSAL & HAZMAT



- Everything you need for a complete and thorough clean up of a large industrial spill.
- Screw on lid makes a tight, secure seal ensuring a secure and leak free transport to a disposal site.
- 65 gallon and 95 gallon spill kits are DOT approved.

DESCRIPTION	PART			
30 Gallon Drum Spill Kit – Blue	Oil-Only	18 gallons sorbent capacity	A	28336
30 Gallon Drum Spill Kit – Blue	Universal	18 gallons sorbent capacity	A	28337
30 Gallon Drum Spill Kit – Blue	Hazmat	18 gallons sorbent capacity	A	28338
30 Gallon Drum Spill Kit Refill	Oil-Only	18 gallons sorbent capacity	A	28336REFILL
30 Gallon Drum Spill Kit Refill	Universal	18 gallons sorbent capacity	A	28337REFILL
30 Gallon Drum Spill Kit Refill	Hazmat	18 gallons sorbent capacity	A	28338REFILL
55 Gallon Drum Spill Kit – Blue	Oil-Only	44 gallons sorbent capacity	A	28333
55 Gallon Drum Spill Kit – Blue	Universal	44 gallons sorbent capacity	A	28334
55 Gallon Drum Spill Kit – Blue	Hazmat	44 gallons sorbent capacity	A	28335
55 Gallon Drum Spill Kit Refill	Oil-Only	44 gallons sorbent capacity	A	28333REFILL
55 Gallon Drum Spill Kit Refill	Universal	44 gallons sorbent capacity	A	28334REFILL
55 Gallon Drum Spill Kit Refill	Hazmat	44 gallons sorbent capacity	A	28335REFILL
65 Gallon Overpack Spill Kit – Yellow	Oil-Only	46 gallons sorbent capacity	A	28330
65 Gallon Overpack Spill Kit – Yellow	Universal	46 gallons sorbent capacity	A	28331
65 Gallon Overpack Spill Kit – Yellow	Hazmat	46 gallons sorbent capacity	A	28332
65 Gallon Overpack Spill Kit Refill	Oil-Only	46 gallons sorbent capacity	A	28330REFILL
65 Gallon Overpack Spill Kit Refill	Universal	46 gallons sorbent capacity	A	28331REFILL
65 Gallon Overpack Spill Kit Refill	Hazmat	46 gallons sorbent capacity	A	28332REFILL
95 Gallon Overpack Spill Kit – Yellow	Oil-Only	73 gallons sorbent capacity	A	28327
95 Gallon Overpack Spill Kit – Yellow	Universal	73 gallons sorbent capacity	A	28328
95 Gallon Overpack Spill Kit – Yellow	Hazmat	73 gallons sorbent capacity	A	28329
95 Gallon Overpack Spill Kit Refill	Oil-Only	73 gallons sorbent capacity	A	28327REFILL
95 Gallon Overpack Spill Kit Refill	Universal	73 gallons sorbent capacity	A	28328REFILL
95 Gallon Overpack Spill Kit Refill	Hazmat	73 gallons sorbent capacity	A	28329REFILL

Non-stock items. Please allow up to 10 days after receipt of order for delivery.

SPILL CONTAINMENT

SPILL CART ON WHEELS – OIL ONLY, UNIVERSAL & HAZMAT

- Developed to contain spills over 100 gallons.
- 4" rubber casters allow for maximum mobility across a plant floor to quickly respond to a spill.
- Refills are also available for large spill carts.



DESCRIPTION			PART	
Large Spill Kit on Wheels – White	Oil-Only	108 gallons sorbent capacity	A	28324
Large Spill Kit on Wheels – White	Universal	108 gallons sorbent capacity	A	28325
Large Spill Kit on Wheels – White	Hazmat	108 gallons sorbent capacity	A	28326
Large Spill Kit on Wheels Refill	Oil-Only	108 gallons sorbent capacity	A	28324REFILL
Large Spill Kit on Wheels Refill	Universal	108 gallons sorbent capacity	A	28325REFILL
Large Spill Kit on Wheels Refill	Hazmat	108 gallons sorbent capacity	A	28326REFILL

SPILL KIT IN ZIPPER POLY BAG – OIL ONLY & UNIVERSAL

- Use around the shop or in a vehicle.
- Kit allows a worker or driver to act quickly when responding to a spill.
- Compact enough to fit easily in a truck cab.



DESCRIPTION	PART	
Poly Bag Spill Kit – Clear Poly, Oil-Only, 5 gallons sorbent capacity	A	28339
Poly Bag Spill Kit – Clear Poly, Universal, 5 gallons sorbent capacity	A	28340

27

SPILL KIT FOR ACIDS/CAUSTICS - 5 GALLONS

- Ideally used in battery shops or any area prone to leaking caustics.
- Sorbent capacity: 5 gallons
- Kit contains:
 - 1 Pail
 - 1 Two lb. Shaker of Neutralizers
 - 5 Acid Absorbing Pads, 15" x 19"
 - 2 Socks
 - 2 Disposable Bags with Ties
 - 1 Scoop
 - 1 Pair of goggles
 - 1 Pair of Nitrile Gloves





DESCRIPTION	PART	
Acid Spill Kit	A	28341
Acid Absorbing Pads (15" x 19")	E	28342

Non-stock items. Please allow up to 10 days after receipt of order for delivery.



SPILL CONTAINMENT

SPILL PALLET – 1 DRUM		
<ul style="list-style-type: none"> Great for safely storing a single 55 gallon drum. 		
		
DESCRIPTION	PART	
1 Drum Spill Pallet, 26" L x 26" W x 6.5" H, 15 gallons containment capacity	A	28350

SPILL PALLET (LOW PROFILE) – 2 DRUM		
<ul style="list-style-type: none"> Store two 55 gallon drums without worrying about spills or leaks. 		
		
DESCRIPTION	PART	
2 Drum Spill Pallet, 26.25" L x 51.5" W x 6.5" H, 32 gallons containment capacity	A	28351
Poly Ramp, 45.5" L x 32" W x 8" H	A	28356

SPILL PALLET (HIGH PROFILE) – 2 DRUM		
<ul style="list-style-type: none"> Store two 55 gallon drums without worrying about spills or leaks. SPCC compliant, so you can be sure that your facility will remain clean and safe. 		
		
		
DESCRIPTION	PART	
2 Drum Spill Pallet, 26.25" L x 51.5" W x 15" H, 68 gallons containment capacity	A	28352

27

SPILL PALLET (LOW PROFILE) – 4 DRUM		
<ul style="list-style-type: none"> Designed for facilities storing multiple drums on location. SPCC compliant, so you can be sure that your facility will remain clean and safe. 		
		
		
DESCRIPTION	PART	
4 Drum Spill Pallet, 51.5" L x 51.5" W x 10" H, 62 gallons containment capacity	A	28353
Poly Ramp, 45.5" L x 32" W x 8" H	A	28356

Non-stock items. Please allow up to 10 days after receipt of order for delivery.
 *SPCC compliant: Drum pallet must contain 110% of the largest container on pallet.

SPILL CONTAINMENT

SPILL PALLET (IN-LINE) – 4 DRUM

- Designed for facilities storing multiple drums on location.
- SPCC compliant, so you can be sure that your facility will remain clean and safe.



DESCRIPTION	PART	
4 Drum Spill Pallet, 106" L x 30.25" W x 6.75" H, 63 gallons containment capacity	A	28354
Poly Ramp, 45.5" L x 32" W x 8" H	A	28356

SPILL PALLET (HIGH PROFILE) – 4 DRUM

- Designed for facilities storing multiple drums on location.
- SPCC compliant, so you can be sure that your facility will remain clean and safe.



DESCRIPTION	PART	
4 Drum Spill Pallet, 26.25" L x 51.5" W x 15" H, 98 gallons containment capacity	A	28355

Non-stock items. Please allow up to 10 days after receipt of order for delivery.

*SPCC compliant: Drum pallet must contain 110% of the largest container on pallet.

SPILL CONTAINMENT

ONE-PIECE SECONDARY CONTAINMENT BERMS

- One-piece secondary containment berm is easily deployed and set up by one or more people
- Deploys in minutes
- Drive in and use
- Snap-up leg supports; manufactured using high tensile patented, unbreakable, non-sparking co-polymer rods
- Leg supports snap into place creating strong dependable side walls
- Leg supports are permanently attached to containment berm



Features

- No difficult assembly
- No air needed
- Stores in a compact shippable size
- Resistant to corrosive solvents
- Long lasting
- Heavy durable fully fuel resistant to all EPA regulations for secondary containment
- High level UV standards

Ground Tarp

- 30 mils minimum reinforced fabric
- High abrasion resistance
- Puncture resistant
- Specially designed to be driven over
- Adds protection from rough sub grades
- Allows the berm systems to be deployed in almost any terrain

Track Belts

- Gives added protection for tire tracks onto and over containment berms and other areas in need of protection
- Heavy duty vinyl coated polyester core
- Rolls out ready to use

DESCRIPTION		LIQUID CAPACITY	PART	
Berm	For size 10' x 10' x 12"	750 gallons	A	9-STC-1010-12
Track Belt Set	For size 10' x 10' x 12"	–	A	9-STC-TB-3-10
Ground Tarp	For size 10' x 10' x 12"	–	A	9-STC-GT-1010
Berm	For size 12' x 36' x 12"	3,240 gallons	A	9-STC-1236-12
Track Belt Set	For size 12' x 36' x 12"	–	A	9-STC-TB-3-36
Ground Tarp	For size 12' x 36' x 12"	–	A	9-STC-GT-1236
Berm	For size 12' x 60' x 12"	5,400 gallons	A	9-STC-1260-12
Track Belt Set	For size 12' x 60' x 12"	–	A	9-STC-TB-3-60
Ground Tarp	For size 12' x 60' x 12"	–	A	9-STC-GT-1260
Berm	For size 14' x 66' x 12"	6,930 gallons	A	9-STC-1466-12
Track Belt Set	For size 14' x 66' x 12"	–	A	9-STC-TB-3-66
Ground Tarp	For size 14' x 66' x 12"	–	A	9-STC-GT-1466

Non-stock items. Please allow up to 10 days after receipt of order for delivery.

SPILL CONTAINMENT

30/45/60 GALLON FLAMMABLE CABINETS

- Safely store combustible fluids that must be stored away from any open flames or electricity
- Store up to 60 gallons
- Available in manual or self close and with one or two shelves
- Bright yellow for visibility
- 2 Doors
- 1 Shelf models
 - 4 gal. / 30 gal.
- 2 Shelf models
 - 45 gal. / 60 gal.



30 gallon flammable



45 gallon flammable



60 gallon flammable

DESCRIPTION			PART	
Storage Cabinet (Self Close) – 2 Shelf	31.25" L x 31.25" W x 65" H	60 gallon capacity	A	28362
Storage Cabinet (Manual Close) – 2 Shelf	31.25" L x 31.25" W x 65" H	60 gallon capacity	A	28363
Storage Cabinet (Manual Close) – 2 Shelf	43" L x 18" W x 65" H	45 gallon capacity	A	28364
Storage Cabinet (Self Close) – 2 Shelf	43" L x 18" W x 65" H	45 gallon capacity	A	28365
Storage Cabinet (Manual Close) – 1 Shelf	43" L x 18" W x 44" H	30 gallon capacity	A	28366
Storage Cabinet (Manual Close) – 1 Shelf	17.5" L x 18" W x 22.5" H	4 gallon capacity	A	28367

45/60 GALLON PAINT AND INK STORAGE CABINETS

- Safely store up to 60 gallons of paint or ink in these cabinets.
- 3 shelf model – 40 gal.
- 5 shelf model – 60 gal.



40 gallon paint and ink



60 gallon paint and ink

DESCRIPTION			PART	
Storage Cabinet (Manual Close) – 3 Shelf	43" L x 18" W x 44" H	40 gallon capacity	A	28360
Storage Cabinet (Manual Close) – 5 Shelf	43" L x 18" W x 65" H	60 gallon capacity	A	28361

GROUNDING WIRES FOR STORAGE CABINETS



- These wires provide maximum protection against any static electricity or sparks that may cause ignition of fuels, paints or inks.
- Helps comply with Uniform Fire Code, Division VIII, Section 79.803
- Used to prevent sparking around flammable or combustible liquids, when used in combination with safety cabinets.

DESCRIPTION			PART	
Bonding Wires – Silver, 3'			A	28368

Non-stock items. Please allow up to 10 days after receipt of order for delivery.

METRIC O-RINGS

BUNA "N" COMPOUND

- TOUGH, 70 DUROMETER BUNA "N" (NITRILE RUBBER) STOCK – PROVIDES SUPERIOR RESISTANCE TO GASOLINE, MOTOR OIL, TRANSMISSION OIL, HYDRAULIC FLUIDS, ANTI-FREEZE, MILD ACIDS, MILD ALKALIES AND WATER.
- PRECISION MANUFACTURED TO EXACTING SPECIFICATIONS – ASSURING MAXIMUM LEAKAGE PROTECTION.
- TEMPERATURE RANGE: -65°F TO 300°F (-54°C TO 149°C)
- IDEAL FOR USE IN ENGINES, EQUIPMENT, FUEL SYSTEMS, CARBURETORS, DRAIN LINES, ETC.



2mm THICK

INSIDE DIA. (A)	OUTSIDE DIA. (B)	PART	INSIDE DIA. (A)	OUTSIDE DIA. (B)	PART	INSIDE DIA. (A)	OUTSIDE DIA. (B)	PART
3mm	7mm	T 60920	9mm	13mm	T 60926	15mm	19mm	T 60932
4mm	8mm	T 60921	10mm	14mm	T 60927	16mm	20mm	T 60933
5mm	9mm	T 60922	11mm	15mm	T 60928	19mm	23mm	T 60934
6mm	10mm	T 60923	12mm	16mm	T 60929	20mm	24mm	T 60935
7mm	11mm	T 60924	13mm	17mm	T 60930	25mm	29mm	T 60936
8mm	12mm	T 60925	14mm	18mm	T 60931	28mm	32mm	T 60937

2.5mm THICK

8mm	13mm	T 60957	16mm	21mm	T 60964	21mm	26mm	T 60968
10mm	15mm	T 60960	17mm	22mm	T 60965	22mm	27mm	T 60969
11mm	16mm	T 60961	18mm	23mm	T 60959	23mm	28mm	T 60970
12mm	17mm	T 60962	19mm	24mm	T 60966	24mm	29mm	T 60971
13mm	18mm	T 60958	20mm	25mm	T 60967	25mm	30mm	T 60972
14mm	19mm	T 60963						

3.0mm THICK

9mm	15mm	R 60976	25mm	31mm	R 60983	35mm	41mm	R 60993
10mm	16mm	R 60977	27mm	33mm	R 60985	36mm	42mm	R 60994
11mm	17mm	R 60978	28mm	34mm	R 60986	38mm	44mm	R 60996
19mm	25mm	R 60979	30mm	36mm	R 60988	39mm	45mm	N 60997
20mm	26mm	R 60980	32mm	38mm	R 60990	42mm	48mm	N 60998
22mm	28mm	R 60981	33mm	39mm	R 60991	45mm	51mm	N 60999
24mm	30mm	R 60982						

3.5mm THICK

28mm	35mm	N 61015	35mm	42mm	N 61019	45mm	52mm	N 61022
29mm	36mm	N 61016	38mm	45mm	N 61020			N
32mm	39mm	N 61017	42mm	49mm	N 61021			

4.0mm THICK

27mm	35mm	N 61023	44mm	52mm	L 61028	53mm	61mm	L 60944
36mm	44mm	N 61024	45mm	53mm	L 61029	54mm	62mm	L 60945
38mm	46mm	N 61025	47mm	55mm	L 60940	55mm	63mm	L 60946
39mm	47mm	L 61006	48mm	56mm	L 60941	56mm	64mm	L 60947
40mm	48mm	L 61007	50mm	58mm	L 60942	57mm	65mm	L 60948
41mm	49mm	L 61026	52mm	60mm	L 60943	60mm	68mm	L 60949
42mm	50mm	L 61008						

27

METRIC SQUARE KEY STOCK

- ZINC PLATED 1045 COLD DRAWN STEEL
- MACHINE CUT ENDS
- TOLERANCES: -.000 TO +.0762mm
IN BOTH DIMENSIONS
- P.S.I. 102,000
- B.H.N. 179-229



12" LENGTHS

SIZE	PART	SIZE	PART
4mm x 4mm	E 60168	10mm x 10mm	C 60173
5mm x 5mm	E 60169	12mm x 12mm	C 60174
6mm x 6mm	E 60170	14mm x 14mm	C 60175
7mm x 7mm	E 60171	16mm x 16mm	C 60176
8mm x 8mm	E 60172	-	-



A "MUST" FOR EVERY SHOP.
100'S OF APPLICATIONS –
A MULTI-PURPOSE ITEM USED IN
ALL PHASES OF MAINTENANCE.
THE RIGHT SIZE AVAILABLE EVERY TIME.

12" LENGTHS

DESCRIPTION	PART
31 Piece Metric Square Key Stock Assortment Contains 5 each of 4mm, 5mm, 6mm, 7mm and 8mm; 3 each of 10mm and 12mm	A 7819